



**LUBE**  
Control

Lube Control Pty Ltd



Trico Corporation

# Spectrum Performance Oil Storage System

Revision: 2/1/24 – 61268 D



**LUBE  
Control**

**Lube Control Pty Ltd**



**Spectrum Performance Oil Storage System**

## TABLE OF CONTENTS

---

<b>TABLE OF CONTENTS</b> .....	<b>1</b>
<b>INTRODUCTION</b> .....	<b>2</b>
<b>IMPORTANT SAFEGUARDS</b> .....	<b>2</b>
<b>WARNINGS</b> .....	<b>3</b>
Electrical Precaution .....	3
Flammable Liquids .....	3
Static Discharge.....	3
Running Dry Gear Pumps .....	4
Possible Pinch Point .....	4
Possible Tipping Point / Caution While Moving.....	4
<b>OVERVIEW</b> .....	<b>5</b>
<b>STEP-UP &amp; INSTALLATION</b> .....	<b>6</b>
Time, Materials, Personnel, and Tool Requirements .....	6
System Placement Determination .....	6
Attaching Watchdog Extreme Humidity Desiccant Breathers (Part #WG-050205-EX) .....	7
Spectrum Color Coding .....	7
Mounting the On/Off Switch for the Electric Motor .....	8
Powering the Electric Motor/Pump .....	8
Adding Additional Performance Stacks to Expand the System.....	8
Mounting the Air Regulator Assemblies for the Pneumatic Motor.....	9
Supplying the Pneumatic Motor with Air .....	10
<b>OPERATION INSTRUCTIONS</b> .....	<b>11</b>
Filling Storage Tank .....	11
Dispensing Lubricant.....	13
<b>FILTER ELEMENT TECHNICAL DATA</b> .....	<b>14</b>
<b>WHEN TO CHANGE THE FILTER AND PROCEDURE</b> .....	<b>15</b>
<b>ISO CLEANLINESS RATING</b> .....	<b>16</b>
<b>MAINTENANCE CHECKLIST</b> .....	<b>17</b>
<b>MOVING THE SYSTEM</b> .....	<b>17</b>
<b>TROUBLESHOOTING</b> .....	<b>18</b>
<b>REPLACEMENT PARTS</b> .....	<b>19</b>
<b>TEMPERATURE VS. VISCOSITY</b> .....	<b>20</b>
<b>LIMITED WARRANTY</b> .....	<b>21</b>

**TRICO CORPORATION**

1235 Hickory Street; Pewaukee, WI 53072  
For Customer Support: 800-558-7008



## INTRODUCTION

Trico Spectrum Oil Storage Systems are an innovative solution to resolving bulk oil storage issues for constricted space requirements. The Performance Stacks are standalone 2 Tank systems that offer individual motors and in-line filtration for each storage tank. All systems come standard with 1-1/4" Heavy Wall Wire-Yarn Reinforced clear Phthalate Free PVC lines and brass shutoff valves. Gravity dispensing valves are standard self-closing bronze with a 3/4" NPT nozzle threading. Each 2-tank stack comes with a 73 Gallon Spill Containment Reservoir with a built-in dispensing tray area. Each electric motor and pump combination draws a maximum of 15.0 Amps, requiring the system to use two different, separate 20-amp circuits. Each pneumatic motor generates a maximum 4 HP at 3000 RPM and can have a maximum inlet pressure of 100PSI. The industrial grade gear pump is positive displacement and self-priming.

Fluid Capacity per Tank	65 Gallons
Containment Capacity	73 Gallons (>110% per Spill Container)
Tank Sight Gauges	3 @ 1" NPT Steel Viewports
Tank Lines	1-1/4" Heavy Wall Wire-Yarn Reinforced clear Phthalate Free
Tank Shut Off Valves	Brass Ball Valves
Dispensing Valves	Self-Closing 1" Bronze with 3/4" NPT Threading
Filter Type	Spin-on
Filter Head By-Pass Pressure	43 PSI differential
Filters Media	10 Micron absolute Beta>200
Replace Element @	40 PSI differential
Filter Collapse Rating	80 PSI differential
Maximum Filter Operating Pressure	120 PSI
Max Temperature	150°F/65°C
Max Viscosity	12,000 SUS (2600 cSt) → ISO 680 at 70°F
Pump Head	Industrial Grade Gear
Pump Relief	105 PSI
Max Flow Rate @ ISO 32, 70°F	4.5 GPM (Electric Motor)
Electric Motor	1-1/2 HP TEFC @ 1750 RPM 60 Hz → #37210 1-1/2 HP TEFC @ 1425 RPM 50 Hz → 37258
Electrical Motor Rating	115V, 60Hz, 15.0A, NEMA 5-20P 220V, 50 Hz, 11.7 A, NO END PLUG
Max Pneumatic Motor Speed	3000 RPM
Max Supply Pressure	120 PSI
Rack Weight Capacity Rating	2500 LBS
Wetted Parts Material Composition	Steel – Stainless, Galvanized & Zinc Platted; Viton; Buna; Brass; Bronze; Iron – Galvanized & Black-Coated; PVC; Aluminum

**Warning:** Do not store flammable products with a flashpoint below 200°F, products with a pH below 3, or products with a pH above 13. Storing unapproved products can result in serious bodily injury or death and will void any product warranty.

## IMPORTANT SAFEGUARDS

- Read and Retain Instructions** - All safety and operating instructions should be read before using the Spectrum Oil Storage System. They also should be retained for future reference.
- Heed Warnings** - All warnings on the product and in the operating manual should be adhered to.
- Follow Instructions** - All operating instructions should be followed.

### **TRICO CORPORATION**

1235 Hickory Street; Pewaukee, WI 53072  
For Customer Support: 800-558-7008



**LUBE  
Control**

**Lube Control Pty Ltd**



**Spectrum Performance Oil Storage System**

4. ALWAYS wear appropriate Personal Protective Equipment while operating this system.
5. ALWAYS check that all system hoses and fittings are securely fastened and in good working condition before operating this system.

## **WARNINGS**

---

### **Electrical Precaution**

Always use safety around electrical equipment, follow instructions to prevent electrical shock. Electrical shock may cause death or other serious bodily harm. Although the Trico Spectrum Oil Storage Systems are designed with Totally Enclosed, Fan-Cooled (TEFC) motors they cannot be submersed into liquids. Use precaution when operating in wet environments and do not allow excess lubricant to encounter electrical components. If fluid does encounter electrical components, immediately disconnect the power by removing the electrical plug at the outlet or turn the power off at the breaker.

Amperage draw from the electric motor varies due to load at normal operating conditions. Full load amperage for the Spectrum Oil Storage System is 15.0A (60Hz), 11.7A (50Hz), and a separate 20 Amp circuit is recommended for each motor on a 60Hz system. Failure to use the appropriate circuit type may cause overloading of the circuit and trip the breaker. Repeated attempts to use equipment on the same tripped circuit will cause an electrical fire. Ensure to consult a certified electrician to identify proper outlets before using equipment.

### **Flammable Liquids**

Do not use with flammable liquids. Do not use in areas where there is presence of large amounts of flammable fumes. Failure to comply may cause an explosion. Always take precautions when working around open fuel sources.

### **Static Discharge**

Due to the rate of flow of oils across different materials there is always a potential to build up a static charge. Static discharge can cause an explosion if near, or around, open flammable fluids. Bonding and ground safety procedures must be used when operating in hazardous duty environments or when there is a danger of static discharge. See National Fire Protection Code 77 for proper grounding and bonding procedures. It is the responsibility of the operator to properly inspect and ground equipment before use, no grounding cabling is included with this system.

The Trico Spectrum Oil Storage Systems are not rated for a hazardous duty environment due to possible static discharge, use proper bonding and grounding per National Fire Protection Code 77. A Bonding system connects various pieces of conductive equipment together to keep them at the same potential. Static sparking cannot take place between objects that are the same potential. Grounding is a special form of bonding in which conductive equipment is connected to an earthing electrode, or to the building grounding system, to prevent sparking between conductive equipment and grounded structures.

Grounding is an electrical connection between a metal vessel, pump, motor, and a constant ground. Failure to bond and ground properly can cause a discharge of static electricity resulting in fire, injury, or death. If in doubt, do not start the pump! Be sure bonding and grounding wires are secure before starting operation. (Ground and bond wires must have less than one-ohm resistance for safe usage. Check continuity before starting.) Always check with a safety engineer when any question arises and periodically check safety procedures with a safety engineer.

#### **TRICO CORPORATION**

1235 Hickory Street; Pewaukee, WI 53072  
For Customer Support: 800-558-7008

Page 3 | 22



**LUBE  
Control**

**Lube Control Pty Ltd**



**Spectrum Performance Oil Storage System**

### **Running Dry Gear Pumps**

The Trico Spectrum Oil Storage Systems are self-priming units. Lubrication is not provided to the pump gears at the factory before the units are shipped. After assembly and before operating for the first time, it is recommended to place a small amount of oil that is intended to be pumped into the suction wand line and allow the fluid to enter the pump gears by elevating the suction wand line higher than the pump head. This should also be done whenever the units have been stationary for over a month or has been cleaned or serviced. ***Running the pump gears dry will cause premature wear and shorten the life of your system.***

### **Possible Pinch Point**

The Trico Spectrum Oil Storage Systems use Self-Closing 1" Bronze Dispensing Valves. These valves are spring loaded to always remain closed. Due to the nature of the self-closing valves, a pinch point may be present on the valve when opening and closing the valves. This pinch point is greatly enhanced when the dispensing valve lines are under pressure, causing a greater force to open, and ultimately close the valves. Please use caution when using the valves and be aware this pinch point does exist.

### **Possible Tipping Point / Caution While Moving**

The Trico Spectrum Oil Storage Systems have an empty weight near 1,000 pounds per 2 Tank Stack. When the systems are filled with lubricants, they can easily weight over 2,000 pounds. Use caution while moving the system around. The system should be empty when moving. Use the appropriate equipment to move the system around. Please follow the *Moving The System* procedure in these instructions if the system needs to be moved.

DO NOT CLIMB on the Trico Spectrum Oil Storage System in anyway. Climbing on the system may cause the system to tip over and cause severe injury including death. The intended use of the system is to be fixed to the floor with the mounting holes located in the spill containment pan skid runners, on a flat, level surface.

#### **TRICO CORPORATION**

1235 Hickory Street; Pewaukee, WI 53072  
For Customer Support: 800-558-7008

Page 4 | 22

## OVERVIEW

Trico Spectrum Oil Storage Systems are meant to store petroleum-based lubricants in a clean, orderly, organized, space saving method. The Performance Stack is a standalone 2 Tank system that offers best practices in contamination control. Each storage tank has in-line filtration, an individual pump/motor, and its own suction wand. This will prevent cross-contamination between different lubricants, by having all independent set ups for each storage tank. The in-line filtration reduces the particulate content of oils as they are being stored before use. With the standalone design, these systems provide flexibility to expand by purchasing additional systems, with the ability to place them anywhere, not necessarily near the other system due to the completely independent design.

Below is an image of the Performance Stack (Part #37210 Electric Motor) which will be used for installation purposes.

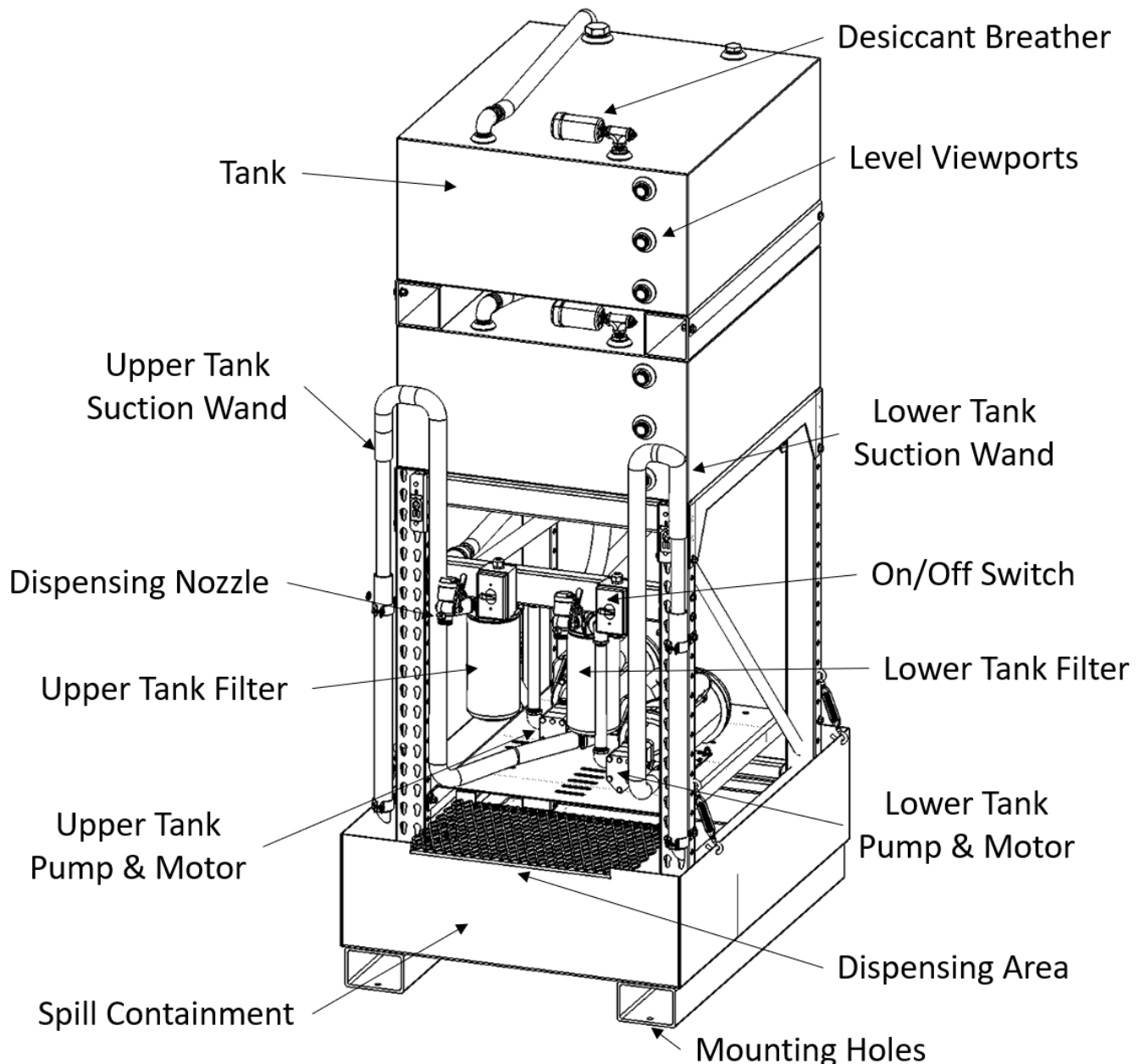

**TRICO CORPORATION**

1235 Hickory Street; Pewaukee, WI 53072  
For Customer Support: 800-558-7008

Page 5 | 22



**LUBE  
Control**

**Lube Control Pty Ltd**



**Spectrum Performance Oil Storage System**

## STEP-UP & INSTALLATION

---

Trico Spectrum Oil Storage Systems come almost fully assembled. They are meant to store petroleum-based lubricants in a clean, orderly, organized, space saving method. The system only requires the Watchdog Extreme Humidity Desiccant Breathers attached, the correct electrical outlet to plug each motor in, and to mount each On/Off switch to make the system usable. Whereas for the pneumatic version, it is attaching the Air regulator assembly, and providing an air supply.

---

*Note: Personal Protective Equipment (“PPE”) should be worn when installing, operating, and maintaining this system.*

---

### Time, Materials, Personnel, and Tool Requirements

- Only one person is needed to complete installation.
- Assembly Time is approximately 15 minutes for a standalone Performance Stack unit.
- Electrical hook-ups and installation should be completed by your authorized electrical personal in accordance with all local, federal, and building regulations.
- A narrow, 22” maximum width, hand pallet truck rated for at least 2,000 lbs can be used to move each unit into its final position.
- An oil filter strap wrench will be needed to tighten or replace filters.
- All fittings already assembled on the system are tightened with thread sealant.

### System Placement Determination

- The system is recommended for indoor use only.
- The system must be installed on a flat, level surface. The surface must have sufficient load-bearing capacity to support the total system (each 2-tank Stack weighs 2,000 lbs filled with lubricant).
- The system can be mounted permanently to the floor using the mounting holes in the Spill Containment. Mounting will not be covered in this manual and will be the responsibility of the end user to mount using the correct hardware.
- Each electric motor on the 37210 and 37258 Electric Performance Stack has a power cord approximately 14 feet in length.
- The electric motor on the 37210 Electric Performance Stack has a full load amperage of 15.0A and a separate 20 Amp circuit is recommended for each motor, requiring two for each Performance Stack.
- The electric motor on the 37258 220V 50Hz Electric Performance Stack has a full load amperage of 11.7A and a separate 20 Amp circuit is recommended for both motors, requiring one for each 220V 50Hz Electric Performance Stack.
- Each pneumatic motor on the 37246 Pneumatic Performance Stack needs a maximum 120PSI air supply with a shut-off valve inline to a 1/4” air nozzle connection.
- There should be a minimum of 12” of space from the back of the Spill Containment. This provides room for the hoses. More room may be required behind the units for maintenance and easier access to the tank shut-off valves, up to 24”.

#### **TRICO CORPORATION**

1235 Hickory Street; Pewaukee, WI 53072  
For Customer Support: 800-558-7008

Page 6 | 22

### Attaching Watchdog Extreme Humidity Desiccant Breathers (Part #WG-050205-EX)

1. Remove desiccant breathers from packaging.
2. Remove sticker from bottom of desiccant breather to allow airflow and activate the desiccant breather.
3. Install desiccant breathers on top of each tank. On top of each tank has a 3/8" NPT female fitting where the desiccant breathers will screw into.

Watchdog Extreme Humidity Desiccant Breathers (Part #WG-050205-EX) mounted shown below:

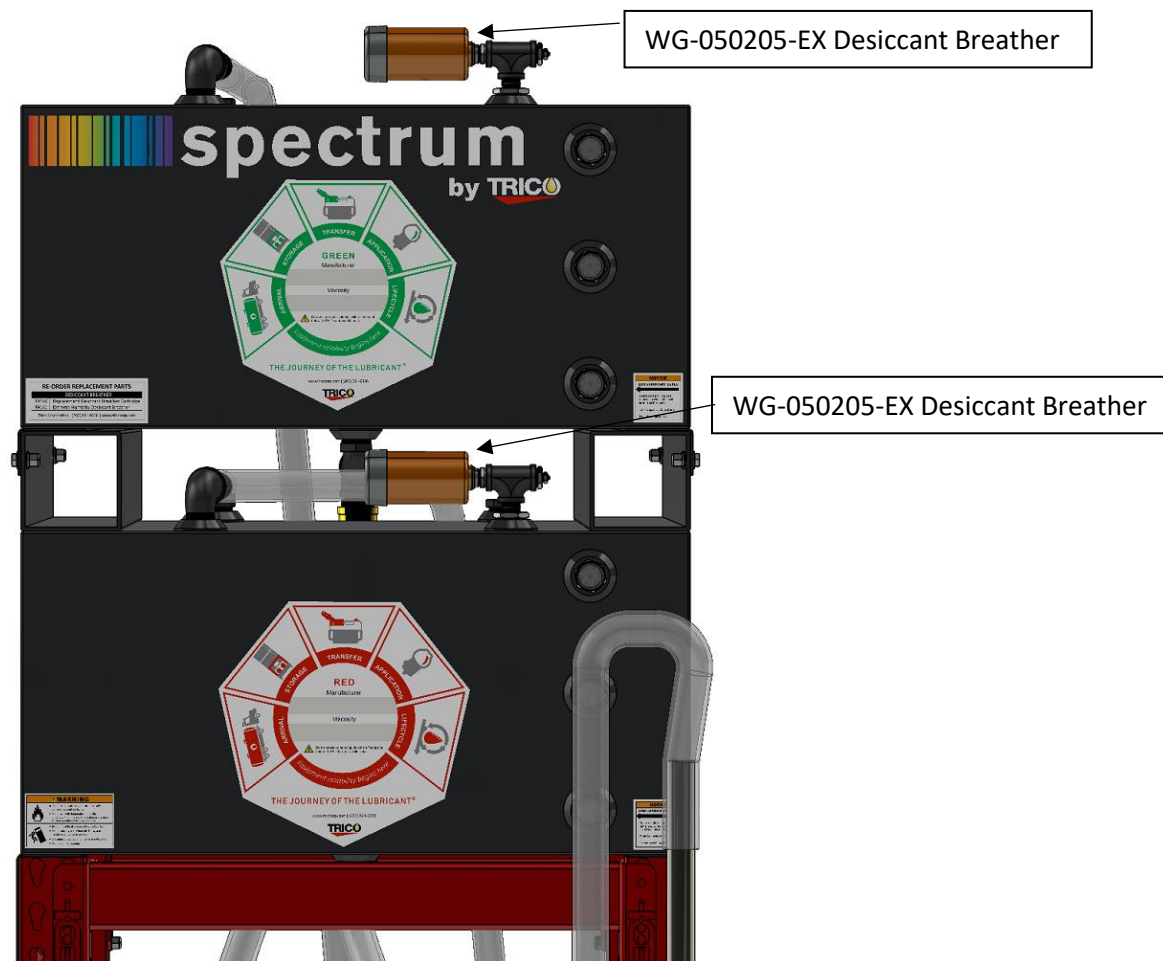

### Spectrum Color Coding

The Spectrum Oil Storage System comes with Spectrum color coded tags and tank labels. Please ensure the tanks, corresponding dispensing nozzles, and corresponding suction wands are color coded to easily identify the correct lubricant to dispense and fill. Assigning specific colors allows for a tagging system to be deployed throughout the lubricant chain within the facility. From the point of storage to the point of application, the operator will know which designated lubricant is to go to each specific lubrication point. Color coding lubricants from the time they enter the facility to the point of use will reduce the amount of lubricant cross-contamination and misapplication that occurs in everyday top-ups, re-lubrication, and re-greasing activities.

#### **TRICO CORPORATION**

1235 Hickory Street; Pewaukee, WI 53072  
For Customer Support: 800-558-7008

### Mounting the On/Off Switch for the Electric Motor

The On/Off Switch that controls each motor has been shipped loose, and not attached onto the system. The power cord connected to each pump has approximately 6 feet before the On/Off Switch. Once the best place for each On/Off switch is determined, remove the double-sided tape strip on the backside of the electrical box and mount each On/Off Switch. The On/Off switch is shown below mounted to the Dispensing Nozzle Bar; however, the switch can be mounted in any location.

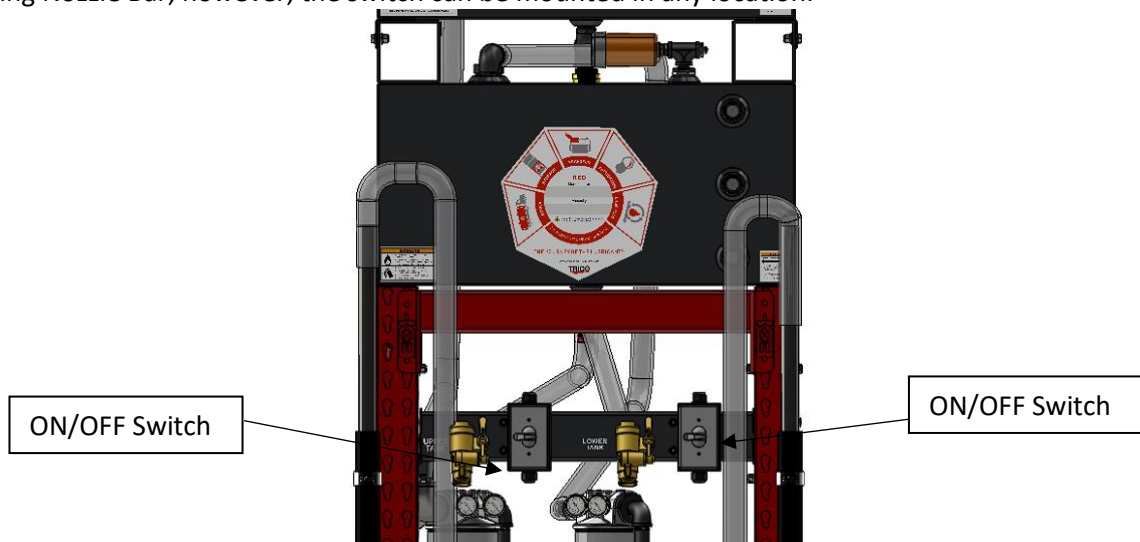

NOTE: The electrical cord connecting each On/Off switch to the motor is not shown in the image above

### Powering the Electric Motor/Pump

For the 37210 Performance System there are two electric motors, each have a full load amperage of 15.0A and a separate 20 Amp circuit is recommended for each motor. Therefore, the 37210 Performance Stack requires two separate 20 AMP circuit outlets. Once the correct outlets have been installed by a certified electrician, making sure the On/Off switch is in the OFF position, place the NEMA 5-20P plug into the receptacle.

For the 37258 220V 50 Hz Performance System, there are two electric motors, each having a full load amperage of 11.7A and a one 20 Amp circuit is recommended for both motors. Due to many different international requirements for electricity, a plug is NOT included on the end of the motor cord. A certified electrician can install the required receptacle and plug for the motors.

### Adding Additional Performance Stacks to Expand the System

The Spectrum Performance Oil Storage System is set up to be a standalone unit. If more storage is required, an additional Performance Stack (Part #37210, #37246, #37258) would be purchased. Since this system is set up to be completely independent, any number of systems can be purchased, to store an unlimited number of lubricants. Additionally, we offer three different types of systems: the Essential Stack which is no filtration and one motor/pump for up to 6 tanks; the Performance Stack which is standalone with one motor/pump for each tank as well as in-line filtration per tank; and the Intelligent Stack which is standalone, one motor/pump for each tank, in-line filtration and kidney-loop filtration per tank, touchscreen with digital display, and fully electronically controlled. With the Spectrum Oil Storage Systems, the possibilities are endless with the different options available for the storage of lubricants.

#### **TRICO CORPORATION**

1235 Hickory Street; Pewaukee, WI 53072  
For Customer Support: 800-558-7008

Page 8 | 22

### Mounting the Air Regulator Assemblies for the Pneumatic Motor

The Air Regulator Assemblies have been shipped loose, and not attached to the pneumatic motors. There is an aluminum mounting bracket attached to the racking uprights for the Air Regulator Assembly below the dispensing rack. There are 2 @ 1/4-20 x 1/2" bolts and washers that need to be removed from the aluminum bracket, and the Air Regulator Assembly needs to be attached to the aluminum bracket. The bolts, washers, and Air Regulator Assembly are shown below. Attach both Air Regulator Assemblies to each bracket on both sides of the uprights for each motor.

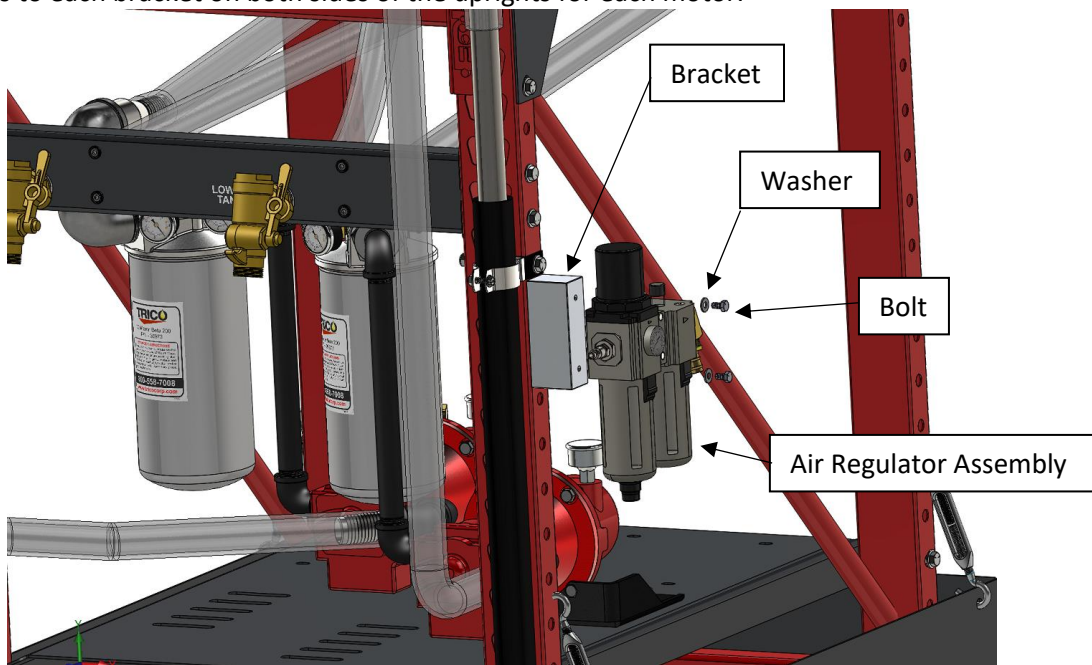

The Air Regulator Assembly needs to be connected to the pneumatic motor with the included 3/8" ID rubber hose. The hose needs to be connected to the push-on hose barb fittings shown below in the red circles. Cut the hose to the correct length, and attach the Air Regulator Assembly to the pneumatic motor.

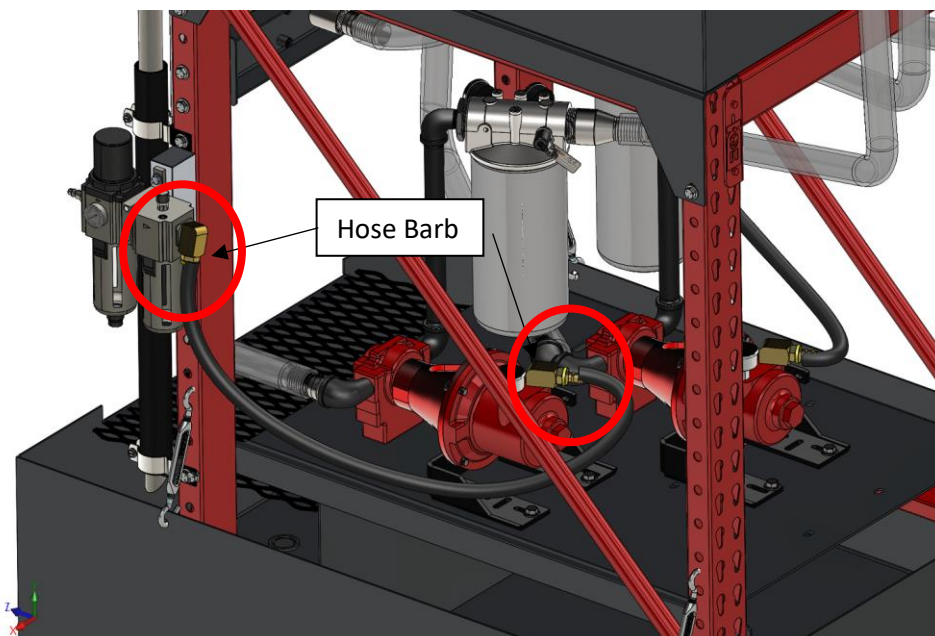

**TRICO CORPORATION**

1235 Hickory Street; Pewaukee, WI 53072  
For Customer Support: 800-558-7008



Lube Control Pty Ltd



Spectrum Performance Oil Storage System

### Supplying the Pneumatic Motor with Air

Air entering the Air Regulator Assembly must be clean and dry for efficient operation of the pneumatic motor as well as to prevent motor damage. Lubrication is critical for efficient operation and long life of the pneumatic motor. Once the Air Regulator is connected to the pneumatic motor with the rubber hosing, supply air can be provided to the regulator. Each pneumatic motor needs a maximum 120PSI air supply with a shut-off valve inline to a 1/4" air nozzle connection. The 1/4" air nozzle is shown below on the front of the Air Regulator. There is no on/off control of the air supply, and a ball valve is suggested inline with the air supply to control the motor.

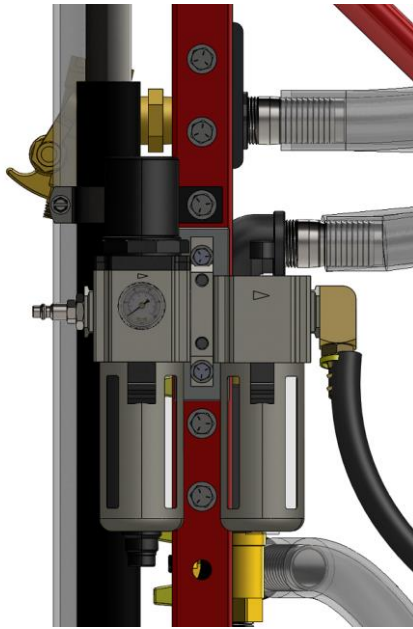

Fill the Lubricator oil reservoir located on the Air Regulator Assembly to the proper level with SAE 10W high detergent or non-detergent motor oil. For food processing applications, White Rex 425 food grade motor oil is FDA approved. Then adjust lubricator to feed 1 drop of oil for every 50 CFM of air while the unit is running, or 1 drop of oil per continuous minute of run time for high speed or continuous duty usage. Do not over oil or exhaust air may become contaminated.

#### **TRICO CORPORATION**

1235 Hickory Street; Pewaukee, WI 53072  
For Customer Support: 800-558-7008

Page 10 | 22

## OPERATION INSTRUCTIONS

### Filling Storage Tank

**WARNING:** The Tank Shut-Off valve, located under the tank, must be in the open position when operation the system.

1. Locate the Tank Shut-Off valve and open it for each tank. Valve locations are shown below looking from the back of the system.

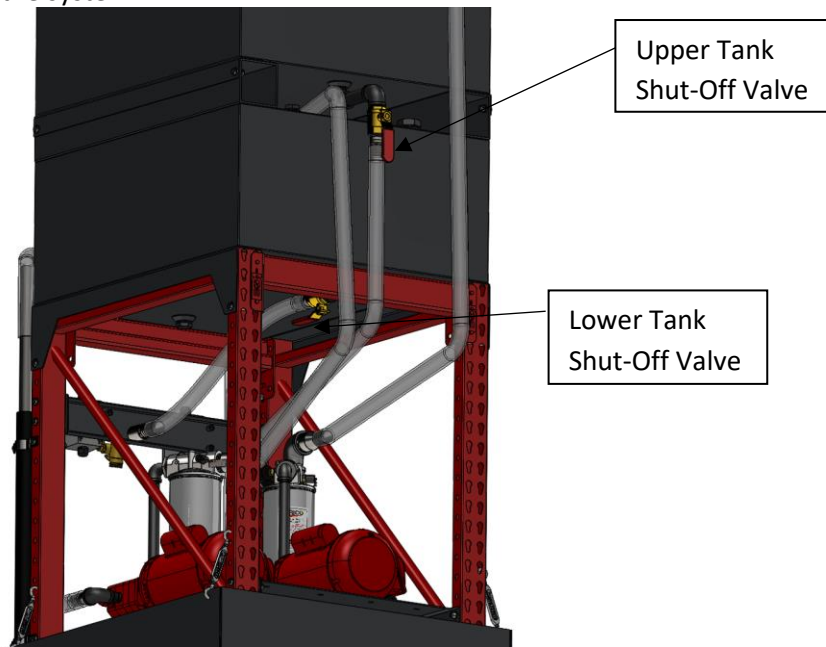

2. Do not fill the tank with 55 gallons until there is room in the tank. The lubricant level should be at the bottom of the lowest Viewport on the tank before refilling the tanks. As noted below, the approximate remaining gallons at the center of the tank's Viewports are shown.

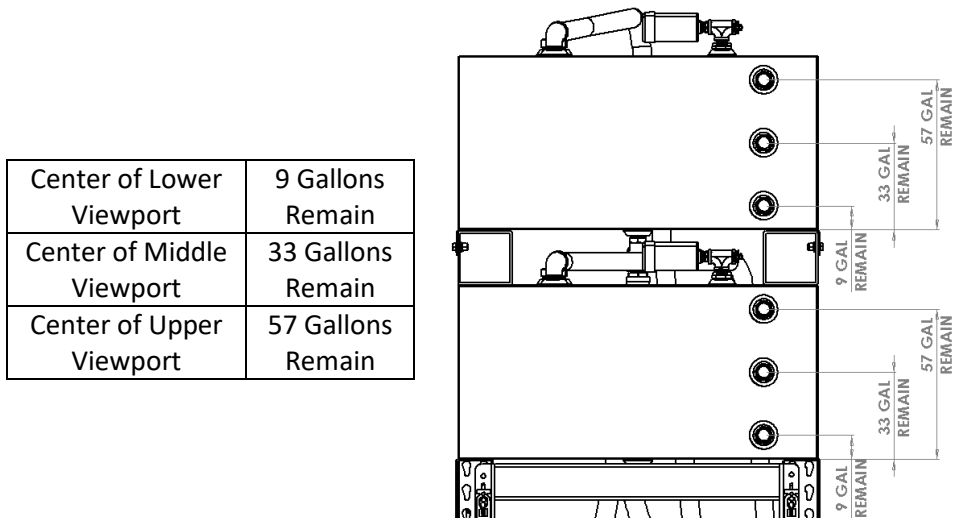

**TRICO CORPORATION**

1235 Hickory Street; Pewaukee, WI 53072  
For Customer Support: 800-558-7008



**LUBE  
Control**

**Lube Control Pty Ltd**



**Spectrum Performance Oil Storage System**

---

**WARNING:** *Do not overfill the Tank. Confirm there is enough room in tank before re-filling with a drum. Best practice is to empty the tank before re-filling.*

---

3. Spin-on filters are hand tightened during assembly at the Trico factory, tighten filters with filter/strap wrench, at the top of the filter where they are the strongest, to form a proper seal with the gasket around the filter and filter head.
4. Once the tank has been emptied or confirmed to fit a drum or whatever size lubricant refill, it is now safe to fill the tank. Place the drum, or similar container, of the lubricant to be filled next to the corresponding tank's suction wand of the system.
5. Attach the appropriate static discharge cabling per National Fire Protection Code 77 to prevent static discharge from filling. Ground and bond wires must have less than one-ohm resistance for safe usage. Check continuity before starting. (NOTE: Cabling is not provided)
6. Lift out suction wand from holder and make sure the wand is clean of any contamination. Then insert suction wand into the full drum of lubricant to be transferred.
7. Start the self-priming gear pump by flipping the On/Off Switch to the "ON" position, or by turning the air supply valve open. The lubricant is now pumped from the drum, through the filter, and out into the top of the tank.

---

**CAUTION:** *Never leave pump unattended while using the system and the pump is powered ON.*

---

8. As the lubricant is being filled, check the Tank Viewports to avoid over-filling. Do not over fill the system tank, this will cause damage to the Watchdog Desiccant Breather.
9. As filter elements become clogged the pressure differential between the gauges increase. When the differential pressure between these gauges equals 40 psi differential the filter element needs to be changed out. If filter elements are not changed before the specified pressure, the system pressure will continue to increase until the built-in pressure relief valve opens. The filter heads go into bypass at 43 psi differential and at this point oil is bypassing the filter media and is no longer being filtered. The pump has a built-in pressure relief at 100 psi at the inlet, at this point the pump will run in bypass relieving the built-up pressure.

---

**Warning:** *Failure to monitor the system and change filter elements may cause filter media to collapse at 80 psi differential which may produce further contamination by inducing filter media into reservoir or container at fluid exit point. Maintain monitoring of the Spectrum Oil Storage System while in operation. Continued running of the pump in pump bypass due to pressure will cause excess heat generation and/or cavitation, reducing the life of the pump.*

---

10. The Spectrum Performance Oil Storage System is equipped with one sample port located after filtration. Lubricant samples may be extracted at this point to monitor lubricant condition.

**TRICO CORPORATION**

1235 Hickory Street; Pewaukee, WI 53072  
For Customer Support: 800-558-7008

Page 12 | 22



## Spectrum Performance Oil Storage System

11. To remove the remaining few gallons from the drum, tip the drum at approximately 30 degrees, with the suction tube placed at the bottom most portion of the drum. The positive displacement pump will completely evacuate all lubricant from the drum.
12. When the drum, or container, is empty, lift the suction wand out of the drum and allow the pump to pull any residual oil remaining in the hose out. Then turn the On/Off Switch to the "OFF" position, or by turning the air supply valve closed.
13. Remove suction wand from empty drum, wipe dry and place in holder.
14. Remove the static discharge cabling and dispose of the empty drum appropriately.

---

*Note: It is normal for air to be trapped inside the hoses during the initial filling of the system. Once the air bubbles have passed thru the system, fluid should be dispensed normally. If air bubbles continue to persist after initial fill, there may be a problem with a fitting, connection, or hosing.*

---

### Dispensing Lubricant

1. Place container on Dispensing Area below the correct tank Dispensing Nozzle.
2. Pull Dispensing Nozzle handle towards you, away from the system, to allow lubricant to flow.
3. Release Dispensing Nozzle handle and the flow will stop.

**CAUTION:** Pinch Point possible when releasing dispensing Nozzle handle.

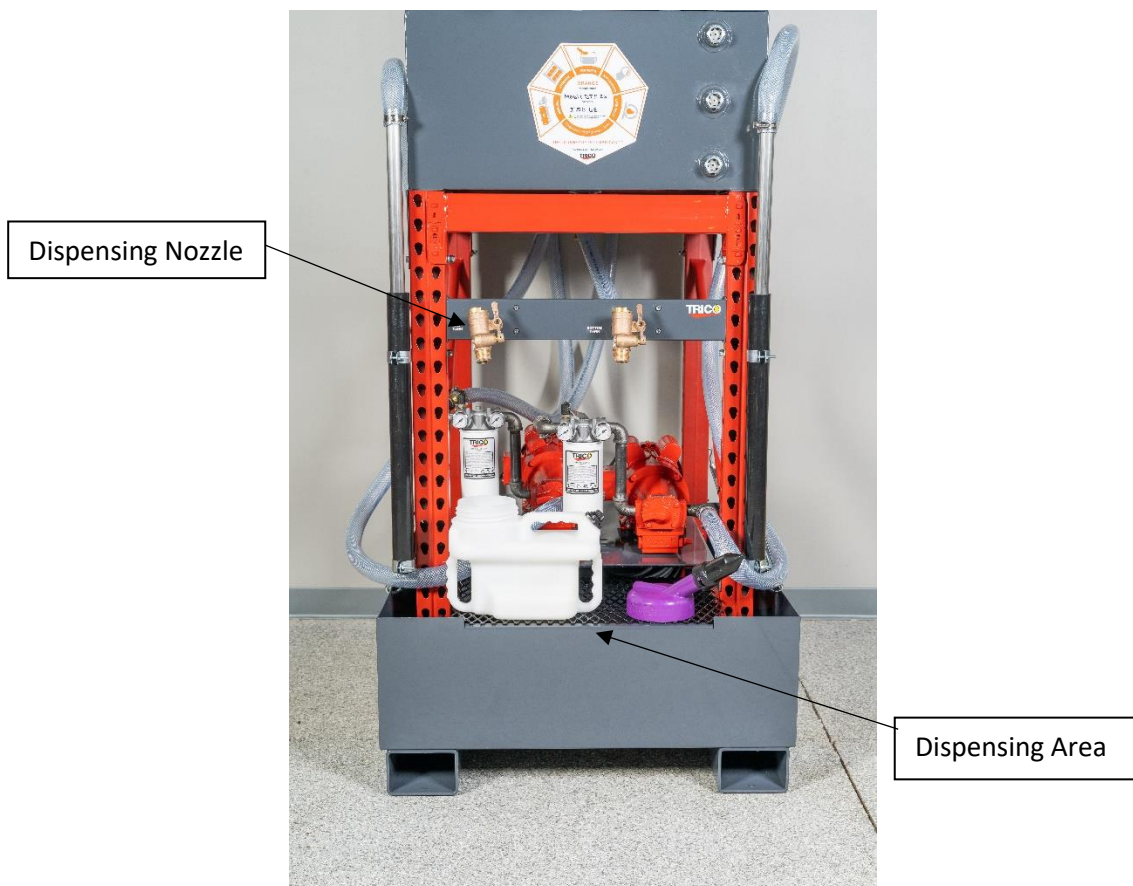

#### **TRICO CORPORATION**

1235 Hickory Street; Pewaukee, WI 53072  
For Customer Support: 800-558-7008

Page 13 | 22



**LUBE  
Control**

**Lube Control Pty Ltd**



**Spectrum Performance Oil Storage System**

## **FILTER ELEMENT TECHNICAL DATA**

---

Filter element life varies with the true dirt holding capacity of the element under dynamic flow conditions and the amount of contamination introduced into the Spectrum Oil Storage System. Choosing the right media for the correct application is determined by the rate of ingestion with the desired ISO cleanliness level. The amount of dirt can vary from day to day and hour to hour, making it difficult to predict when an element will become fully loaded. Increasing the rate of fluid flow increases the ability of the filter to trap particles. The effectiveness of the filter elements should be determined by contamination monitoring. Our oil analysis laboratory has a wide range of oil analysis capabilities to help determine and trend fluid conditions.

### **High Water Content Fluids**

High water content fluids consist of either water and soluble mineral based oil, or water and soluble synthetic oil. The oil proportion is usually 5% but may vary from 2% to 10%. All Trico particulate filter medias are compatible with these types of fluids and should be used in lieu of the Trico water removal filters. However, the high specific gravity and low vapor pressure of these fluids can create a potential for severe cavitation; therefore, monitoring of the Spectrum Oil Storage System with the use of these fluids is highly recommended. Failure to identify cavitation will lead to destruction of the pump valves and filter media.

### **Inverted Emulsions**

Inverted Emulsions consist of a mixture of petroleum-based oil and water. Typically, the proportions are 60% oil and 40% water. All Trico particulate filter medias are compatible with these types of fluids and should be used in lieu of the Trico water removal filters. Filters should be sized conservatively for water emulsions since they are non-Newtonian and their viscosities are a function of shear. Potentials do exist for cavitation similar to high water-based fluids; therefore, monitoring of the Spectrum Oil Storage System with the use of these fluids is highly recommended. Failure to identify cavitation will lead to destruction of the pump valves and filter media.

### **Water Glycols**

Water glycols consist of a mixture of water, glycol, and various additives. All Trico particulate filter medias are compatible with these types of fluids and should be used in lieu of the Trico water removal filters. Potentials do exist for cavitation similar to high water-based fluids; therefore, monitoring of the Spectrum Oil Storage System with the use of these fluids is highly recommended. Failure to identify cavitation will lead to destruction of the pump valves and filter media.

### **Phosphate Esters**

Phosphate Esters are classified as synthetic fluids. All Trico particulate and water removal filter medias are compatible with these types of fluids.

#### **TRICO CORPORATION**

1235 Hickory Street; Pewaukee, WI 53072  
For Customer Support: 800-558-7008

Page 14 | 22



**LUBE  
Control**

**Lube Control Pty Ltd**



**Spectrum Performance Oil Storage System**

## **WHEN TO CHANGE THE FILTER AND PROCEDURE**

Each tank's filter head is outfitted with two pressure gauges. The first gauge nearest to the pump indicates the pressure being produced by the pump. The second gauge near the discharge hose indicates the pressure after the filter element. To determine when each filter element is at its maximum holding capacity, calculate the differential pressure by subtracting the higher pressure from the lower pressure to get the total differential pressure across the single filter head. Differential pressure is used to determine filter usage. Filters should be changed at 40 PSI differential.

Example:

P1 (Pressure Produced by Pump)= 43 psi

P2 (After Filter)= 35 psi

Differential Pressure= P1-P2 = 43psi -35psi = 8psi (filter still has remaining life)

To change the filter:

1. Place an oil catch pan beneath the filter to catch remaining oil in the filter and head that will come out during the filter change.
2. Using an oil filter strap wrench at the top of the filter, turn the filter counterclockwise and unthread the filter from the head.
3. Dispose of remaining oil in the filter and the used filter in accordance with local environmental laws and practices.
4. Remove the old gasket from the filter head and wipe excess oil residue from the head.
5. Remove the new filter from its packaging and insert the new gasket provided with the filter into the gasket groove of the head.
6. Thread the new filter onto the head turning it counterclockwise and hand tighten.
7. Using the oil filter strap wrench, place the strap near the top of the filter, to prevent collapsing, and turn the filter 1/4 turn to tighten.
8. Turn on, dispense fluid, and observe the filter gasket checking for leaks.
9. If leaking is noticed around the filter gasket, tighten the filter another 1/4 turn with the strap wrench and repeat the procedure to check for leaks.

<b>Replacement Filters</b>	<b>Part Number</b>
Particulate Filter - 3 Micron Microglass Spin On Beta $\geq$ 200 Absolute	36972
Particulate Filter - 10 Micron Microglass Spin On Beta $\geq$ 200 Absolute	36973
Particulate Filter - 20 Micron Microglass Spin On Beta $\geq$ 200 Absolute	36974
Water Filter - 10 Micron Nominal Spin On	36975
Water Filter - 25 Micron Microglass Spin On Beta $\geq$ 200 Absolute	36995

**TRICO CORPORATION**

1235 Hickory Street; Pewaukee, WI 53072  
For Customer Support: 800-558-7008

Page 15 | 22



### ISO CLEANLINESS RATING

Lubricating oils stored in bulk containers may contain contaminants. Ordinarily it has been thought lubricants stored in drums prior to use were contaminant-free; however, it has now been learned it is beneficial to filter lubricants even prior to its use as the original container may impart impurities to the lubricants prior to its first use. Most rotating equipment is manufactured to a class 2 or class 3 fit typical of most industrial operations. Hydraulic components and rotary screw compressors tend to have tighter tolerances in the sliding and rotating elements. Clearances in components are used to establish cleanliness requirements. The best source for cleanliness requirements is from the equipment manufacturer. In general, as the viscosity of the oil increases the cleanliness level decreases. Below is a general guideline for cleanliness levels.

ISO Oil Grade Classification	Cleanliness Code (R4/R6/R14)
32	16/14/11
46	16/14/11
68	17/14/12
100	18/15/13
150	18/15/13
220	19/16/14
320	19/16/14
460	19/16/14
680	20/18/14

Determining the ISO Cleanliness level of equipment requires analysis of the running lubricating oil. Trico's oil analysis laboratories can provide an accurate indication of the ISO Cleanliness level of lubricating oil before and after filtration. Each number in the ISO code represents the micron range of particulate in which the count lies within (R<sub>4</sub> microns/ R<sub>6</sub> microns/ R<sub>14</sub> microns). **Example: 19/16/14, the 19 code shows that count of 4-micron particle lies between 5,000 and 2,500 per ml of fluid.**

ISO Number	Particle Count per ml of fluid		
25	160,000	to	320,000
24	80,000	to	160,000
23	40,000	to	80,000
22	20,000	to	40,000
21	10,000	to	20,000
20	5,000	to	10,000
19	2,500	to	5,000
18	1,300	to	2,500
17	640	to	1,300
16	320	to	640
15	160	to	320
14	80	to	160
13	40	to	80
12	20	to	40
11	10	to	20
10	5	to	10
9	2.5	to	5
8	1.3	to	2.5

ISO 320  
19/16/14

↗  
 ↘  
 ↘

**TRICO CORPORATION**

1235 Hickory Street; Pewaukee, WI 53072  
For Customer Support: 800-558-7008



**LUBE  
Control**

**Lube Control Pty Ltd**



**Spectrum Performance Oil Storage System**

## MAINTENANCE CHECKLIST

---

Trico Spectrum Oil Storage Systems should have scheduled, routine maintenance every three months after installation. Personal Protective Equipment (“PPE”) should be worn when performing any maintenance service on the system.

---

***CAUTION:** The Tank Shut-Off valves, located under the tank, must be in the closed position when servicing the system. Main power supply should be removed and locked out before any service is performed.*

---

- ✓ Check and replace Watchdog Extreme Humidity Desiccant Breathers. The orange beads will turn dark green indicating the desiccant has been used.
- ✓ Check and Replace Spin-on Filters if differential pressure is 40 PSI or higher
- ✓ Inspect all hoses for crack or kinks
- ✓ Inspect all fitting for leaks
- ✓ Inspect and tighten all bolts as needed
- ✓ Clean all surfaces and motor
- ✓ Empty Spill Containment pan either by the 1” NPT hole on bottom of pan, or by using the suction wand and discharge valve into a separate container
- ✓ For the pneumatic motor, check the Air Regulator assembly prior to use to confirm there is oil in the Lubrication reservoir

## MOVING THE SYSTEM

---

Trico Spectrum Oil Storage Systems can be easily moved around with a hand pallet truck, or forklift. Follow the following procedure to relocate the system.

1. Empty all Tanks and hoses.
2. Close Tank Shut-Off Valves on the bottom of the Tanks.
3. Disconnect the power by removing the electrical plug at the outlet or turn the power off at the breaker to each motor. Or disconnect the air supply from the Air Regulator Assemblies.
4. Empty and clean out Spill Containment.
5. Remove bolts from surface mounting holes, if mounted.
6. Move System into new location using a hand pallet truck or forklift. There should be a minimum of 12” of space from the back of the Spill Containment. This provides room for the hoses. More room may be required behind the units for maintenance and easier access to the tank shut-off valves, up to 24”.
7. Once in place, continue with normal installation steps.

### **TRICO CORPORATION**

1235 Hickory Street; Pewaukee, WI 53072  
For Customer Support: 800-558-7008

Page 17 | 22



**TROUBLESHOOTING**

The following troubleshooting guide gives issues, causes, and corrective action. If any of these actions do not solve the issue entirely, please contact Trico for additional support.

Symptom	Possible Cause(s)	Corrective Action
Pump system does not prime	Suction wand above liquid	Ensure open end of suction wand remains completely below surface of liquid
	Clogged suction wand and/or discharge hose line to top of tank and/or Spin-on filter	Clean suction wand and/or discharge hose line to top of tank and/or replace Spin-on filter
	Suction wand line too long	Reduce length in suction line to reduce pressure
Insufficient flow	Clogged/ kinked discharge hose line or nozzle	Remove and flush discharge hose line and nozzle, inspect for damage
	Clogged filter	Check differential pressure between gauges, if 40 PSI or greater, change filter element
	Fluid viscosity exceeds recommended viscosity for motor	Check viscosity of fluid at temperature. See SUS vs. Temp. chart or contact fluid supplier. If viscosity exceeds maximum cSt, fluid must be warmed to reduce viscosity
Fluid Leaking from filter area or any fittings	Loose filter and/or fittings/connections	Check tightness of filter element to ensure proper seal, check hose/fitting connections
Electric motor does not function/ or stops working	Power On/Off switch not fully switched	Check On/Off switch
	No power to receptacle	Check outlet for power and breaker
	Unit has overheated tripping internal overload breaker	Turn unit power to the "OFF" position, allow motor to cool, turn back to "ON" position and resume filling
	Unit generates excessive heat	Fluid viscosity exceeds maximum recommended viscosity
Tank is not dispensing fluid	Tank Shut-Off Valve is closed	Open Tank Shut-Off Valve below the tank to have gravity feed for the Dispensing Nozzle
	Dispensing Nozzle is clogged	Clean Dispensing Nozzle to remove contamination or clogs

**TRICO CORPORATION**

1235 Hickory Street; Pewaukee, WI 53072  
For Customer Support: 800-558-7008

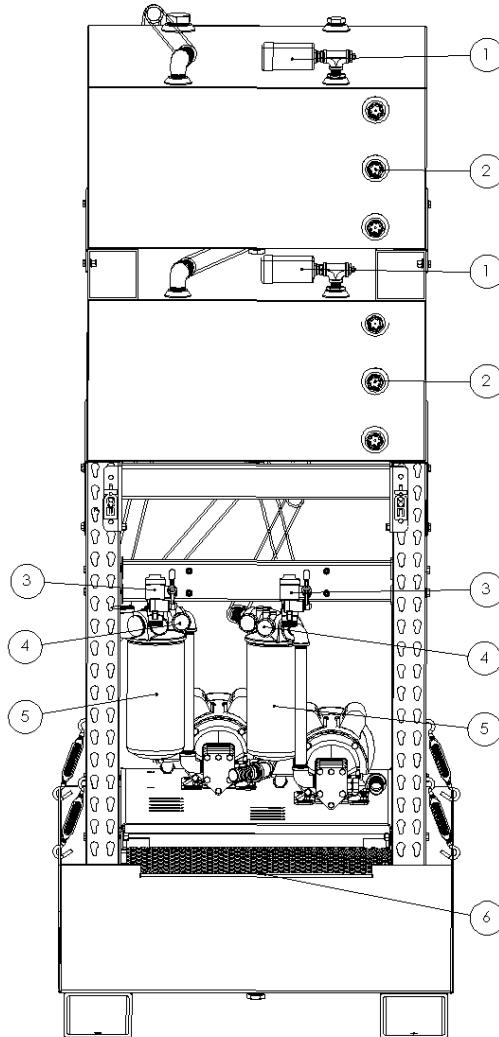
**REPLACEMENT PARTS**

Item #	Part Number	Description	Qty
1	WG-050205-EX	Watchdog Extreme Humidity Desiccant Breather	2
2	34307	1" NPT Viewport with Baffle - Steel	6
3	18363	1" NPT Dispensing Nozzle - Brass	2
4	16183	Filter Gauge, 100 PSI, 1/8" MNPT	4
5	36973	Particulate Filter - 10 Micron Microglass Spin On Beta $\geq$ 200 Absolute	2
6	18313	Dispensing Area Expanded Metal PVC Coated Mesh	1
Below Tanks	18354	Tank Shut-Off Valve, 1" NPT, Brass	2

Replacement Filters	Part Number
Particulate Filter - 3 Micron Microglass Spin On Beta $\geq$ 200 Absolute	36972
Particulate Filter - 10 Micron Microglass Spin On Beta $\geq$ 200 Absolute	36973
Particulate Filter - 20 Micron Microglass Spin On Beta $\geq$ 200 Absolute	36974
Water Filter - 10 Micron Nominal Spin On	36975
Water Filter - 25 Micron Microglass Spin On Beta $\geq$ 200 Absolute	36995

**TRICO CORPORATION**

1235 Hickory Street; Pewaukee, WI 53072  
For Customer Support: 800-558-7008

Page 19 | 22



**LUBE**  
Control

Lube Control Pty Ltd



Spectrum Performance Oil Storage System

## TEMPERATURE VS. VISCOSITY

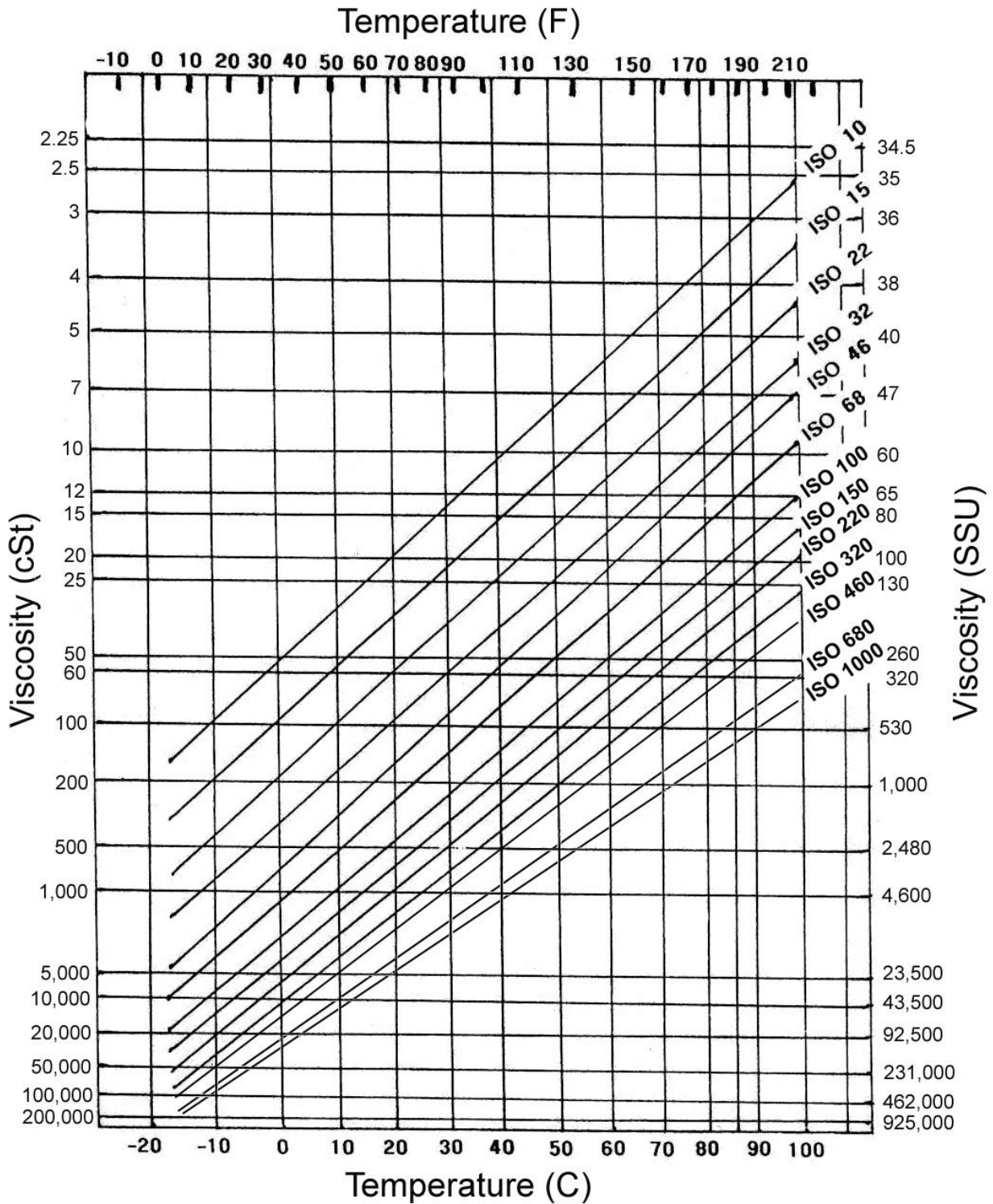

**TRICO CORPORATION**

1235 Hickory Street; Pewaukee, WI 53072  
For Customer Support: 800-558-7008



**LUBE  
Control**

**Lube Control Pty Ltd**



**Spectrum Performance Oil Storage System**

## **LIMITED WARRANTY**

---

Trico warrants to the original purchase only, that these Spectrum Oil Storage Systems (the "Product") are free from defect in material and workmanship and will remedy any such defect according to the terms of this Limited Warranty. Trico will repair (or at its option, replace) at no charge any defective component(s) of Trico's Spectrum Oil Storage System for twelve (12) months from date of purchase.

To make request or claim for service under this Limited Warranty, the original purchaser must return the Product, shipping prepaid, in the original shipping container or equivalent, to Trico, after receiving return authorization from Trico and assuming the risk of loss or damage in transit.

This Limited Warranty shall not apply if the Product has been damaged due to abuse, negligence, misuse, misapplication, or accident after the Product has been shipped. Trico does not warranty any damage cause by third party or malicious software.

ALL EXPRESS AND IMPLIED WARRANTIES FOR THIS PRODUCT, INCLUDING THE WARRANTIES OF MERCHANTABILITY AND FITNESS FOR A PARTICULAR PURPOSE, ARE LIMITED IN DURATION TO A PERIOD OF ONE (1) YEAR FROM THE DATE OF PURCHASE FOR THE SPECTRUM OIL STORAGE SYSTEM, AND NO WARRANTIES, WHETHER EXPRESS OR IMPLIED, WILL APPLY AFTER THESE PERIODS.

IF THIS PRODUCT IS NOT IN GOOD WORKING ORDER AS WARRANTED ABOVE, YOUR SOLE REMEDY SHALL BE REPAIR OR REPLACEMENT AS PROVIDED HERE. IN NO EVENT WILL TRICO BE LIABLE TO YOU FOR ANY DAMAGES, INCLUDING ANY LOST PROFITS, LOST SAVINGS OR OTHER INCIDENTAL OR CONSEQUENTIAL DAMAGES ARISING OUT OF THE USE OR INABILITY TO USE SUCH PRODUCT, EVEN IF TRICO HAS BEEN ADVISED OF THE POSSIBILITY OF SUCH DAMAGES, OR FOR ANY CLAIM BY ANY OTHER PARTY.

This warranty gives you specific legal rights, and you may also have other rights which may vary from state to state. If any provision of this Limited Warranty is held to be unenforceable for any reason, it shall be modified rather than voided, if possible, in order to achieve the intent of the parties. In such event, all provisions of this Limited Warranty shall be deemed valid and enforceable to the full extent.

Trico Corporation  
1235 Hickory Street  
Pewaukee, WI 53072  
800.558.7008 or 262.691.9336  
[www.tricocorp.com](http://www.tricocorp.com)

### **TRICO CORPORATION**

1235 Hickory Street; Pewaukee, WI 53072  
For Customer Support: 800-558-7008

Page 21 | 22



**Lube Control Pty Ltd**



**Spectrum Performance Oil Storage System**

**TRICO CORPORATION**

1235 Hickory Street; Pewaukee, WI 53072  
For Customer Support: 800-558-7008

Page 22 | 22