



**LUBE  
Control**

Lube Control Pty Ltd



**CLOSED SYSTEM**  
With Sight Gauge / Constant Level Oiler

# Read Instructions Before Installing

- DO remove the reservoir from the CLOSED SYSTEM during installation and removal.
- DO NOT install or remove the CLOSED SYSTEM with or by use of the reservoir assembly.
- DO NOT use the CLOSED SYSTEM for stepping, standing, or heavy loading as these actions could cause a change in oil level settings and may cause leaks.
- DO use the bottom fluid port if oil level is set at the lowest level for optimal oil feeding.

## Items Needed:

- (2) - 1/8" NPT x 1/4" OD Male Connector
- (1) - 1/4" OD section of Copper Tubing or Nylon Tubing (length will vary, tubing is used to connect oiler to equipment)
- (1) - Pipe Thread Sealant
- (1) - 1/4" NPT Male x 4" Nipple Connector

## To Install:

1. Prior to installing the CLOSED SYSTEM, shaft rotation direction must be determined, typically indicated by an arrow on the casting of the equipment. Install oiler on the side of the equipment facing the direction of shaft rotation to prevent misfeeding of the oiler (see Fig 1).
2. Loosen set screw on reservoir assembly. Remove reservoir and put aside (Fig. 2).
3. Verify that there are no contaminants or noticeable particles in the CLOSED SYSTEM or bearing housing.
4. Tighten supplied plug in side or bottom fluid port, sealant is not necessary on plug. If using side fluid port to connect CLOSED SYSTEM to the bearing housing, tighten plug in bottom fluid port. If using bottom fluid port to connect CLOSED SYSTEM to the bearing housing, tighten plug in side fluid port (Fig. 2).
5. Apply pipe thread sealant to both ends of a 1/4" NPT male nipple (not included). Tighten nipple in remaining fluid port and bearing housing. If bottom fluid port is remaining, an elbow (not included) may need to be used. The CLOSED SYSTEM should be parallel to the bearing housing in a vertical position within  $\pm 1^\circ$  (Fig. 3).
6. Apply pipe thread sealant to a 1/8" NPT x 1/4" OD male connector (not included) and tighten it into the vent port on the CLOSED SYSTEM.
7. Apply pipe thread sealant to the second 1/8" NPT x 1/4" OD male connector (not included) and tighten it into the vent port on the bearing housing.
8. Connect a section of 1/4" O.D. copper or nylon tubing to the 1/8" NPT connectors (not included). This will serve as the vent line (fig. 3).
9. With 5/32" allen key, adjust the collar to desired fluid level. Bottom of collar indicates fluid level (see back side for dimensions from centerline of side port to bottom of collar.)
10. Fill the bearing chamber through the main body of the CLOSED SYSTEM until it reaches just below the optimum fluid level visible in the sight. Use the reservoir to feed oil to the proper level.
11. Use a disposable funnel, fill reservoir 2/3rds with the recommended oil.
12. Place thumb over reservoir spout, invert, and insert the spout into the main body of CLOSED SYSTEM until upper casting bottoms out on the collar.
13. Oil may drain out of the reservoir and into bearing housing. Secure set screws on upper casting.
14. Start up machine and verify proper oil level is being maintained.

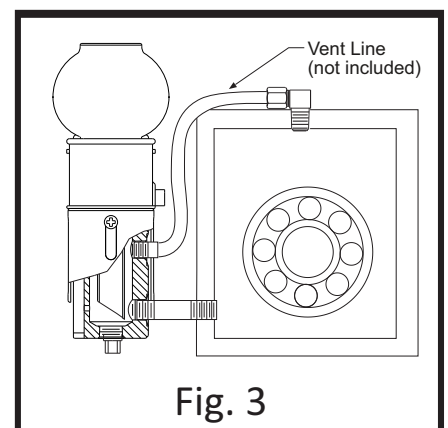
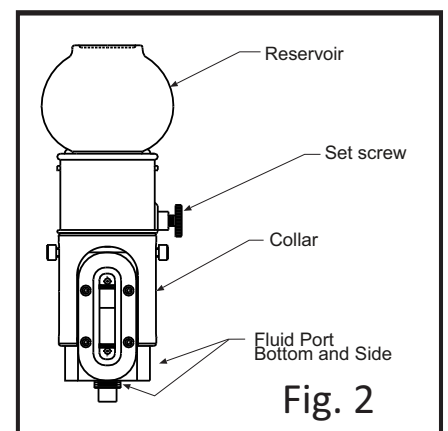
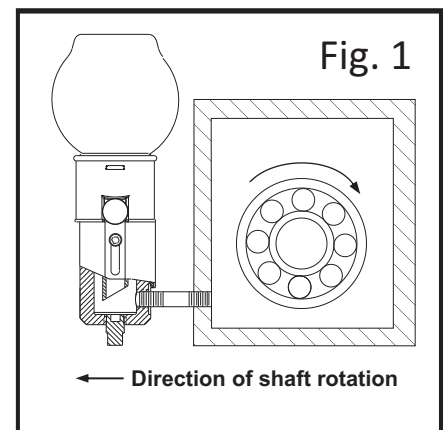



**LUBE  
Control**

Lube Control Pty Ltd

**Product Ordering:**

MODEL #	CAPACITY	DIM A	DIM B MIN.	DIM B MAX.	NPT*
30203	4 OZ.	2-11/16	7-1/16	7-13/16	1/4"
30205	8 OZ.	3-3/16	8	8-3/4	1/4"
30210	16 OZ.	4-1/8	8-7/8	9-5/8	1/4"

\* - Side and bottom ports, vent line is 1/8" NPT.

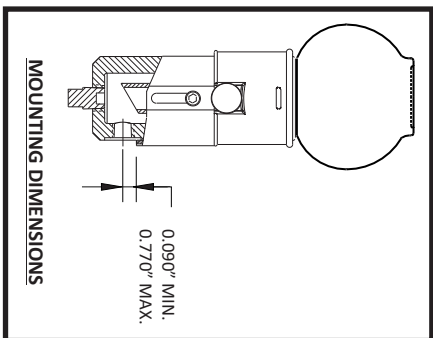
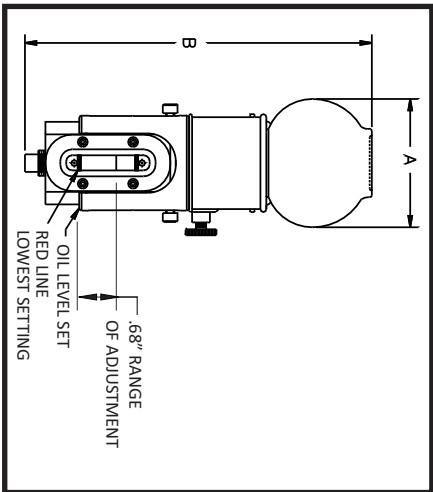

**Replacement Parts:**

ITEM #	DESCRIPTION	MODEL #
1	4 Ounce Reservoir Assy.	26113R
	8 Ounce Reservoir Assy.	26115R
	16 Ounce Reservoir Assy	26120R
2	Set Screw	10267
3	O-Ring 1.375" ID x .062 CS	12829
4	Sight Gauge	26121R
5	1/4" Square Plug	10321
6	Closed System Lower Casting Assm	13604R
7	Std Closed System Collar Assm Red Closed System Collar Assm	13607R 13610R

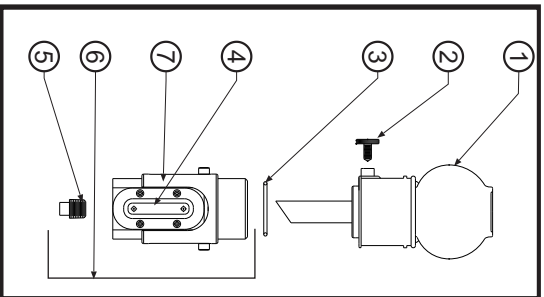

**Deluxe Closed Systems and Installation Kits:**

DELUXE INSTALLATION KIT	MODEL #
Deluxe Installation Kit - Closed System	16-00368
COMPLETE PUMP KIT	
Desiccant Breather EX	WG-050205-EX
Closed System 4 oz with Wire Guard	40101
Loctite 565 Thread Sealant - 6 ml	69012

- 316 Stainless Steel Fittings
- Stainless Steel Braided Vent Line
- EX Style Breather - Check Valve Included

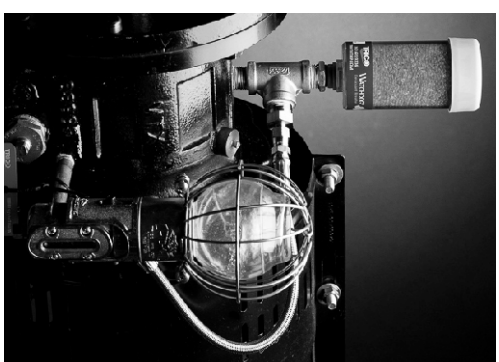

**Basic Closed Systems and Installation Kits:**

BASIC INSTALLATION KIT	MODEL #
Basic Installation Kit - Closed System	16-00370
COMPLETE PUMP KIT	
Desiccant Breather EX	WG-050205-EX
Closed System 4 oz with Wire Guard	40101
Loctite 565 Thread Sealant - 6 ml	69012

- Brass/Plated Fittings
- LDPE Plastic Tube
- Mini Standard Breather



Scan this QR Code to watch a video on installing the Closed System Opto-Matic® Oiler.

**See Reverse Side For Specific Instructions On Installing The Closed System**