

INSTRUCTION MANUAL

TWIN PEDESTAL METAL HOSE REELS

LT SERIES



MODEL NUMBERS
L-AWTP1015
L-AWTP1215
L-OTP1215
L-GTP1015
L-GTP0615

INSTRUCTION MANUAL

TWIN PEDESTAL METAL HOSE REELS



WARNING

Read carefully and understand all INSTRUCTIONS before operating. Failure to follow the safety rules and other basic safety precautions may result in serious personal injury. Save these instructions in a safe place and on hand so that they can be read when required. Keep these instructions to assist in future servicing.

GENERAL SAFETY



WARNING

The warnings, cautions, and instructions discussed in this instruction manual cannot cover all possible conditions or situations that could occur. It must be understood by the operator that common sense and caution are factors that cannot be built into this product, but must be supplied by the operator.

1. Keep the work area clean and dry.
2. Keep children away from work area.
3. Only use this equipment for what it has been designed for. Do not modify this equipment in any way.
4. Check for damaged or worn parts before using this product. Replace any damaged or worn parts immediately.
5. **Do Not** overreach and keep proper footing and balance at all times.
6. **Do Not** use the equipment when tired or under the influence of drugs, alcohol, or medication.

SAFETY PRECAUTIONS

1. Use proper eye protection when assembling and using the hose reel.
2. Keep children away from the work area.
3. Personal injury and/or equipment damage may result if proper safety precautions are not observed.
4. Ensure that reel is properly installed before connecting input and output hoses.
5. Bleed fluid/gas pressure from system before servicing reel.
6. Before connecting reel to supply line ensure that pressure does not exceed maximum working pressure rating of reel.
7. Remember, even low pressure is very dangerous and can cause personal injury or death.
8. If a leak occurs in the hose or reel, remove system pressure immediately.
9. Ensure that reel, hose, and equipment being service are properly grounded.
10. If reel ceases to unwind or rewind, remove system pressure immediately.
11. Do not pull or jerk on hose.



WARNING

Exposure of skin directly to pressurized air, or fluids could result in severe bodily injury.

TWIN PEDESTAL METAL HOSE REELS

INSTALLATION

1. Prior to mounting the hose reel, ensure that the supply line pressure does not exceed the maximum working pressure of the hose reel.
2. Unpack and inspect reel for damage. Turn by hand to check for smooth operation.
3. Check for completeness.
4. Position the reel on the floor, wall or ceiling. Secure into place using four mounting bolts.
5. Depending on where the reel is placed, it may be necessary to adjust the hose bumper and guide arm to use the hose properly. See the instructions on the next page to adjust the hose bumper and reposition the guide arm.

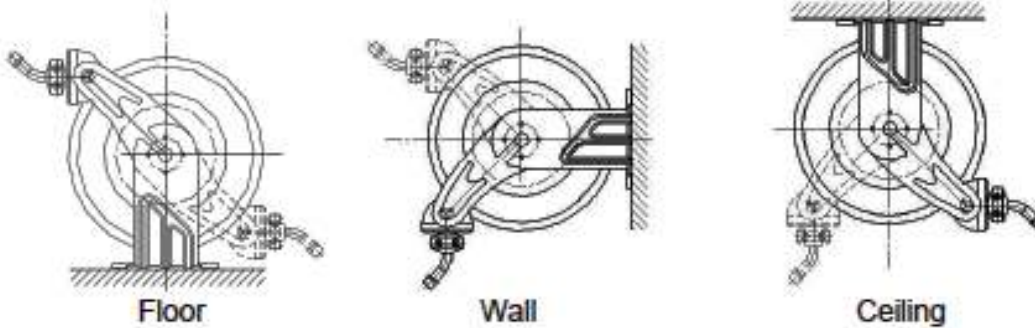

ADJUSTMENTS

Spring tension

WARNING

Use extreme caution as the reel is under tension. Avoid releasing latch mechanism.

1. If necessary, adjust spring tension on reel by adding or removing wraps of hose from spool, one wrap at a time, until desired tension is obtained. Add wraps to increase tension. Remove wraps to decrease tension.
2. Pull out the hose until the latch pawl is engaged. Loosen the hose bumper, then either add wraps or decrease the wraps.

CAUTION

When adding wraps of hose, be careful not to exceed the winding mechanism's spring capacity. Add just enough wraps of hose to achieve the desired tension. Damage to the winding mechanism will result if spring is over-tensioned.

Adjusting the hose bumper

1. Pull out the hose until the latch pawl is engaged, loosening the slotted screws and slide the bumper to the desired position, retighten the screws, then pull hose to disengage the latch.

TWIN PEDESTAL METAL HOSE REELS

Repositioning Guide Arm

1. Pull out hose until the latch pawl is engaged. Remove bumper by removing the slotted screws.
2. Disengage the latch pawl while maintaining a firm hold on spool. Turn the spool hand over hand approximately two or three revolutions in the direction of the direction of the drive spring until tension is removed.
3. Remove the nuts and washer holding the guide arm and shift to base.
4. Revolute the guide arm and adjust to any of the two positions hinted.
5. According to each mounting application, recommend Guide Arm positions
6. Replace and tighten the nuts and washer.
7. Tighten the drive spring by turning the spool two or three revolutions and engage the latch pawl.
8. Pull the hose through the roller opening in the guide arm and replace the hose bumper.

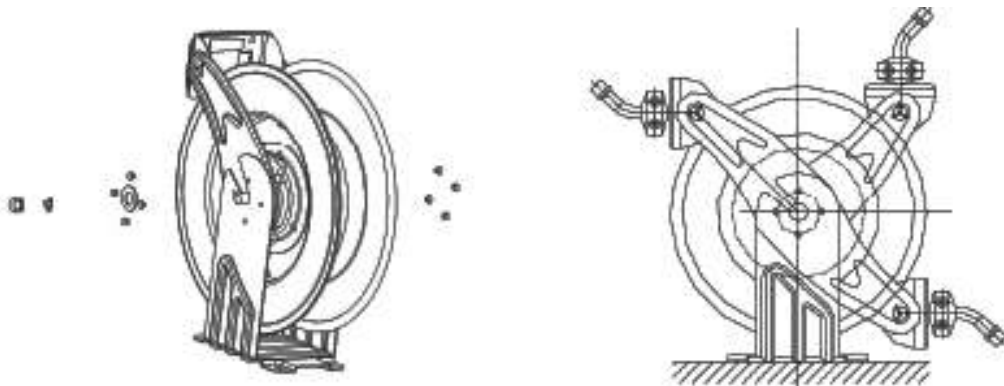

SERVICE INSTRUCTIONS



WARNING: Before performing any service, always disconnect and lock out compressed air or fluid, and remove all spring tension.

Replacing the hose

1. To remove the hose
2. Pull out the hose leaving 2 to 3 feet on the spool. Engage the latch pawl.
3. Unthread the hose at the connection to the swivel tube. Remove the hose.
4. To install the hose
5. Slide the hose through the guide arm rollers and opening of the spool. Apply thread tape or sealant to hose threads.
6. Screw hose fitting into threaded fitting on swivel. Tighten connection with a wrench on fitting.
7. Install hose bumper on working end of hose if required.
8. Disengage latch pawl and allow hose to retract.

TWIN PEDESTAL METAL HOSE REELS

Replacing the swivel

1. If the swivel is leaking, replace the O-ring or seal (#31) and washer (#30) by removing the lock washer (#40) and the part of the swivel shaft.
2. If the balls (#37) wear-out, replace by removing the lock washer (#40).
3. Replace the new seal by clipping the lock washer (#40). Replace the part of the swivel shift by clipping the lock washer (#40).

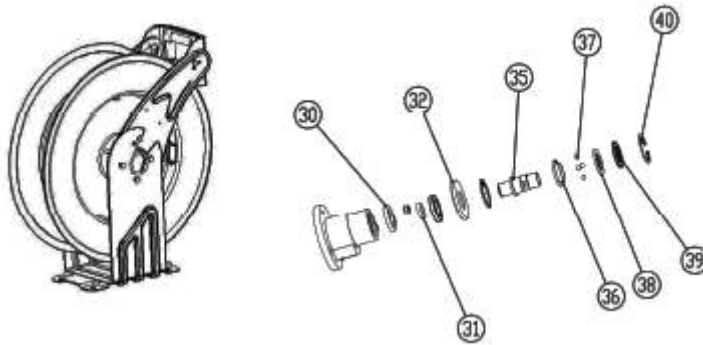

SPECIFICATIONS

Part number	Description	Weight (Kg)	Hose	Pressure	Inlet	Outlet
L-AWTP1015	Tw in Pedestal Air/Water Reel	22.5	10mm (3/8") x 15m (50 ft)	290 psi (20 bar)	3/8"BSPT (M)	3/8"BSPT (M)
L-AWTP1215	Tw in Pedestal Air/Water Reel	25	12.5mm (1/2") x 15m (50 ft)	290 psi (20 bar)	1/2"BSPT (M)	1/2"BSPT (M)
L-OTP1215	Tw in Pedestal Oil Reel	25	12.5mm (1/2") x 15m (50 ft)	2300 psi (160 bar)	1/2"BSPT (M)	1/2"BSPT (M)
L-GTP0615	Tw in Pedestal Grease Reel	24.5	6mm (1/4") x 15m (50 ft)	5800 psi (400 bar)	1/4"BSPT (M)	1/4"BSPT (M)
L-GTP1015	Tw in Pedestal Grease Reel	25	10mm (3/8") x 15m (50 ft)	5000 psi (330 bar)	3/8"BSPT (M)	3/8"BSPT (M)

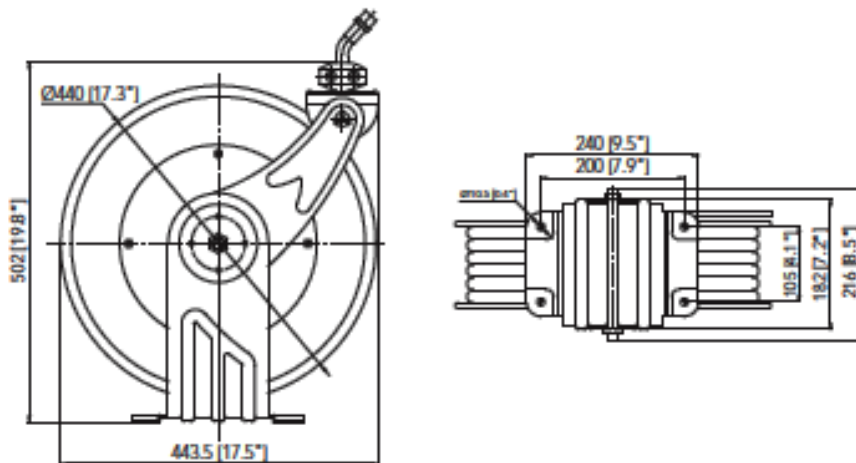

TWIN PEDESTAL METAL HOSE REELS

EXPLODED AND PARTS LIST

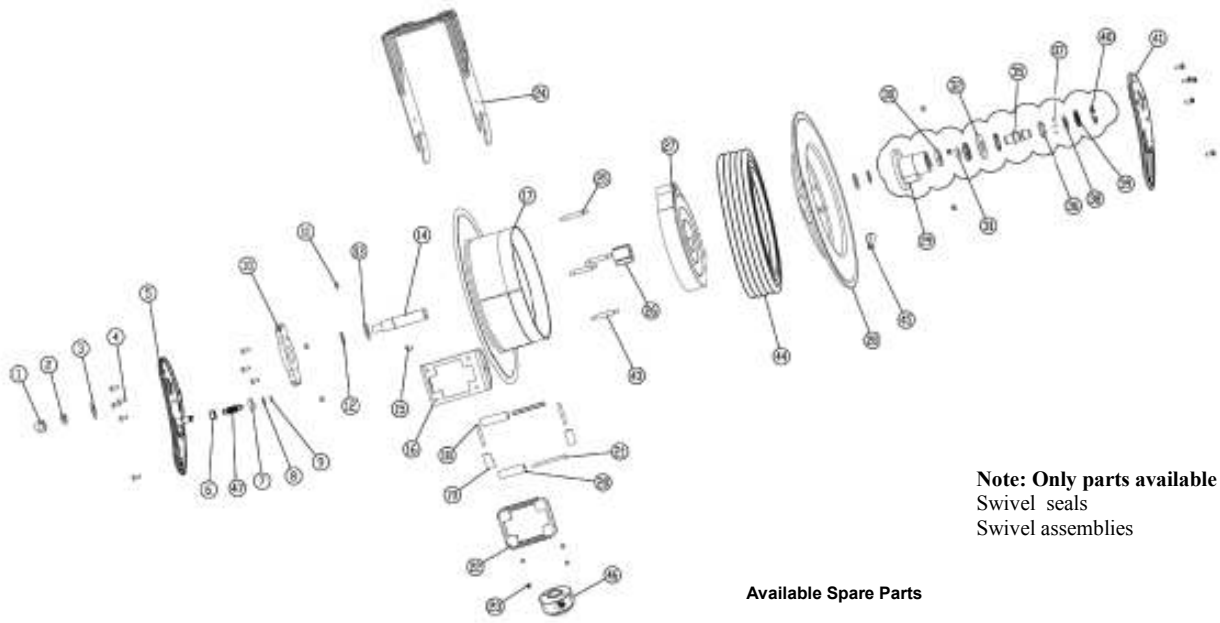

Note: Only parts available
Swivel seals
Swivel assemblies

Available Spare Parts

Model No	Type	Hose stopper	Swivel
L-AWTP1015	Air/Water	L-SK254S	L-SK265S
L-AWTP1215	Air/Water	L-SK255S	L-SK266S
L-OTP1215	OIL	L-SK256S	L-SK268S
L-GTP0615	Grease	L-SK253S	L-SK261S
L-GTP1015	Grease	L-SK254S	L-SK262S

Part No.	Description	Q'ty	Part No.	Description	Q'ty
1	Nut	1	25	Double bolt	3
2	Spring washer	1	26	Spring core	1
3	Washer	2	27	Spring	1
4	Bolt	9	28	Drum	1
5	Bracket arm	1	29	Swivel shaft	1
6	Washer	1	30	Washer	2
7	Ratchet	1	31	O-ring or seal	1
8	Washer	1	32	Washer	1
9	Lock washer	1	33	-	-
10	Click pulley	1	34	-	-
11	Nut	8	35	Swivel shaft	1
12	Lock washer	2	36	Bearing cover	1
13	Washer	4	37	Ball bearing	17
14	Shaft	1	38	Bearing washer	1
15	Key	1	39	Washer	1
16	Guide sub-plate	1	40	Lock washer	2
17	Drum	1	41	Bracket arm	1
18	Roller axle	2	42	-	-
19	Roller	2	43	Double bolt	1
20	Roller	2	44	Hose assembly	1
21	Roller axle	2	45	Clamp	1
22	Guide plate	1	46	Stopper assembly	1
23	Bolt	4	47	Ratchet spring	1
24	Base	1			

TWIN PEDESTAL METAL HOSE REELS

TROUBLE SHOOTING

Problem(s)	Possible Cause	Corrective Action
Fluid path (plumbing and/or Swivel) is leaking or damaged	<ul style="list-style-type: none"> a) Maximum pressure rating for reel has been exceeded b) Application is not compatible with plumbing and/or swivel seal materials. 	<ul style="list-style-type: none"> a) Replace or repair damaged components. Consult factory. Check maximum pressure rating of reel. b) Contact factory to determine chemical compatibility or environmental issues (i.e. temperature rating).
Hose will not fully retract	<ul style="list-style-type: none"> a) Outlet nozzle, gun or tool is too heavy. b) Spring is fatigued. c) Field installed hose is too long. 	<ul style="list-style-type: none"> a) Add spring tension. See "Spring Tension Adjustment". b) Add spring tension. See "Spring Tension Adjustment". Replace Spring Canister if required. c) Call local distributor for correct specified hose length.
Hose will not retract at all	Spring has lost all tension or has possibly broken	Reinstall Spring Tension
Reel will not latch	<ul style="list-style-type: none"> a) Incorrect operation b) Dog spring or locking cam is broken or worn 	<ul style="list-style-type: none"> a) To latch the reel, pull out the hose and allow it to retract after hearing the first second or third "click". b) Replace dog spring or locking cam.
Fluid leaks from swivel	<ul style="list-style-type: none"> a) Swivel seals are damaged or worn b) Inlet hose is not flexible 	Replace swivel seals. See "Swivel Seal Replacement". Caution: Be sure leak is not at Hose Fitting!
Swivel assembly is not moving freely or locking up	Inlet hose is not flexible causing side force on swivel	Properly tighten inlet hose. Hand tighten fitting, plus 1/2 turn with wrench.



Lube Control Pty Ltd



INSTRUCTION MANUAL

TWIN PEDESTAL METAL HOSE REELS

Note: Limited parts available

For Warranty terms and Conditions refer to