

# TWIN PEDESTAL METAL HOSE REEL

**INSTRUCTION MANUAL**  
(Including Stainless Steel Hose Reels)



## Introduction

Thank you for purchasing a Macnaught Twin Pedestal heavy duty metal hose reel.

The Macnaught range of twin pedestal heavy duty metal hose reels have been designed using the highest quality, heavy gauge materials and are fitted with purpose specific hose and swivels. There are models available for Air/Water, Oil, Grease and Diesel.

## Important Information

**PLEASE READ THIS SAFETY INFORMATION CAREFULLY BEFORE USE.**

Read and retain this instruction manual to assist you in the operation and maintenance of this product.

'Cautions' are listed throughout this manual to advise of actions that may cause damage to your equipment.

### CAUTION

***Make sure the line pressure does not exceed the rated operating pressure of your model hose reel, refer specifications.***

### CAUTION

***Exposure of the skin directly to pressurized air or fluid could result in severe bodily injury.***

### CAUTION

***Before carrying out any maintenance turn off and disconnect the supply line to the reel and carefully release the hose line pressure.***

## Installation Procedure

1) Using the four holes in the base, mount the reel in the desired location. Be sure to use appropriate hardware and tighten securely.

2) Apply Teflon tape or pipe sealant to supply line threads, attach to reel inlet and tighten. The other end of incoming line can now be connected to desired supply source. Tighten stopper bolts, and unlatch the reel.



3) Apply Teflon tape or pipe sealant to outlet fitting on reel hose, then attach to desired tool, or nozzle. Check connection for leakage, also check hose reel for correct operation. ( see Operation section.)

4) If hose stopper adjustment is required, pull hose from reel and allow to latch at desired length. Loosen stopper bolts and slide stopper to a position close to the hose guide.

5) Re-tighten stopper bolts and check operation.

## Operation

1) Check reel for correct operation by slowly pulling out the hose. A "clicking" noise will be heard every half revolution of the drum.

2) To latch the reel, pull out the hose and allow it to retract after hearing the first, second or third "click".

3) To unlatch, slowly pull out the hose until the "clicking" noise stops, then let the hose retract until the hose stop rests against the hose guide.

### CAUTION

***Always hold on to the hose while it is rewinding.***

4) Periodically check the hose condition for wear or damage, and check the swivel fitting for leakage. Replace any worn, damaged, or leaking parts.

## Maintenance Procedures

### Adjusting Spring Tension

- 1) Pull out approximately 2m (6ft) of hose and allow the drum to latch.
- 2) Remove hose stopper from hose, and feed hose back through the guide.
- 3) Wrap the hose one time around the drum to increase tension or un-wrap hose one time from drum to decrease tension.
- 4) Re-insert hose through guide, and install stopper onto the hose end.
- 5) Unlatch the Drum and check tension. Pull hose from reel, and adjust stopper position if necessary.

### Replacement of Swivel Seats

- 1) Turn off the pump and release hose line pressure.
- 2) Disconnect supply line from swivel inlet.
- 3) Remove the outlet nozzle, gun or tool and hose stopper. Unlatch the reel and carefully allow the hose to slowly rewind until there is no spring tension remaining.
- 4) Manually unwind the hose assembly from the drum.
- 5) Remove the circlip from the swivel shaft, and remove the swivel body from the shaft.
- 6) Replace the swivel seals and re-fit the swivel body onto the reel axle.
- 7) Manually rotate the drum assembly (away from the roller guides) and manually recoil the hose onto the drum.
- 8) Add tension to the reel by carefully rotating the drum and hose assembly (towards the roller guides) 4 complete turns, slide the hose through the roller guides and allow the reel to latch.
- 9) Fit the hose stopper to the hose end, release the drum latch, and slowly allow the hose to slowly rewind onto the reel.
- 10) Re-connect inlet supply line.
- 11) Check all connections for leaks.

### Hose Replacement

- 1) Turn off and disconnect the supply to reel and release hose line pressure.
- 2) Pull out approximately 2m (6ft) of hose and allow the drum to latch.

3) Remove the outlet nozzle, gun or tool and hose stopper. Unlatch the reel and carefully allow the hose to slowly rewind until there is no spring tension remaining.

4) Manually unwind the hose assembly from the drum. Carefully disconnect and remove the hose from shaft joint inside the reel.

5) Connect your new hose assembly to shaft joint in the reel.

6) Manually rotate the drum assembly (away from the roller guides) and manually recoil the hose onto the drum.

7) Add tension to the reel by carefully rotating the drum and hose assembly (towards the roller guides) 4 complete turns, slide the hose through the roller guides and allow the reel to latch.

8) Fit the hose stopper to the hose end, release the drum latch, and slowly allow the hose to slowly rewind onto the reel.

### Spring Canister Removal

- 1) Pull out the hose approximately 1m (3ft) and latch the reel.
- 2) Remove the outlet nozzle, gun or tool and hose stopper.
- 3) Carefully unlatch the reel and firmly hold the drum. Allow the drum to slowly unwind until it stops and no spring tension remains.
- 4) Carefully remove the nuts and washers located around the drum assembly.



**CAUTION**  
There is a large spring inside which can cause severe injury if not handled correctly.

- 5) Carefully remove both the front and back spring canister covers together as an assembly.
- 6) Carefully sit the drum canister down so as the flat inner plate flat is facing up.
- 7) Carefully remove the flat inner plate to expose the spring.
- 8) Inspect and replace the complete drum assembly if the spring is found to be damaged.



**CAUTION**  
Do NOT under any circumstances remove the spring from the canister.

## Maintenance Procedures

### Spring Canister Replacement

- 1) Slide the flat inner plate over the shaft on the reel.
  - 2) Check the correct orientation of the spring locating boss. Remove the boss from the middle of the spring canister and slide the boss onto the shaft on the reel.
  - 3) Carefully hold the centre of the spring up in the middle of the drum, at the same time slide the drum assembly over the centre boss on the shaft.
- Note:** The spring will automatically locate itself into the centre boss when you re-tension the reel.
- 4) Replace all the washers and nuts around the outside of the drum assembly and securely tighten.
  - 5) Turn the drum anti-clockwise until you feel the spring start to tension, then turn the drum three complete turns and latch the drum.
  - 6) Feed the hose through the hose guide, fit the hose stopper, then unlatch the drum. The hose stopper should now sit snugly against the hose guide.

### Latch Replacement

- 1) Working from the swivel side of the reel, remove the 4 bolts holding the swivel body to the axle, then remove the swivel body.
- 2) Remove the circlip holding the axle bearing in place.
- 3) Remove the nut and bolt holding the roller guide to the support arm.
- 4) Remove the 4 large bolts holding the support arm to the mounting bracket located below the swivel body.
- 5) Slide the support arm off the axle.
- 6) Inspect the latch assembly, and replace any worn or damaged parts.
- 7) Assembly is a reversal of the disassembly procedure.

## Troubleshooting Guide

| Problem                      | Cause                                   | Remedy   |
|------------------------------|---|--|
| Hose does not fully retract  | Outlet nozzle, gun or tool is too heavy | Add spring tension (See "Adjust Spring Tension")   |
|                              | Spring is fatigued                      | Add spring tension (See "Adjust Spring Tension")<br>Replace spring canister is required (See "Replacement of Spring Canister") |
|                              | Replacement hose is too long            | Fit correct length hose (Refer to Hose Specifications")  |
| Hose does not retract at all | Spring has broke or has lost tension    | Replace spring canister is required (See "Replacement of Spring Canister")   |
| Reel does not latch          | Incorrect operation                     | Reel latches on first, second or third 'click'. After the third click reel automatically rewinds                               |
|                              | Latch assembly is worn                  | Replace the latch assembly   |
| Fluid leaks from the swivel  | Swivel seals are worn                   | Replace swivel seals. (See "Replacement of Swivel Seals")  |

## Product Specifications

| Model     | Description | Hose Specifications |        |                       | Reel Thread Size | Max. Operating Temperature |
|-----------|-------------|---------------------|--------|-----------------------|------------------|----------------------------|
|           |             | I.D.                | Length | Max. Working Pressure |                  |                            |
| MDTP2510  | Air/Water   | 25mm (1")           | 10m    | 3450 kPa (500psi)     | 1" BSP           | 60°C                       |
| MDTP2520  | Diesel      | 25mm (1")           | 20m    | 3450 kPa (500psi)     | 1" BSP           | 60°C                       |
| MATP1220  | Air/Water   | 12.5mm (½")         | 20m    | 2070 kPa (300psi)     | ½" BSP           | 60°C                       |
| MATP1920  | Air/Water   | 19mm (¾")           | 20m    | 2070 kPa (300psi)     | ¾" BSP           | 60°C                       |
| MOTP1220  | Oil         | 12.5mm (½")         | 20m    | 6900 kPa (1000psi)    | ½" BSP           | 100°C                      |
| MOTP1920  | Oil         | 19mm (¾")           | 20m    | 6900 kPa (1000psi)    | ¾" BSP           | 100°C                      |
| MGTP0615  | Grease      | 6mm (¼")            | 15m    | 34450 kPa (5000psi)   | ¼" BSP           | 100°C                      |
| MGTP0915  | Grease      | 9mm (⅜")            | 15m    | 34450 kPa (5000psi)   | ⅜" BSP           | 100°C                      |
| MAVTP2500 | AV GAS      | 25mm (1")           | NIL    |                       | 1" BSP           | 80°C                       |

## Spare Part Listing

### Twin pedestal reels (with hose)

| Item no | DESCRIPTION                 |          |          |          |          |          |          |          |
|---------|-----------------------------|----------|----------|----------|----------|----------|----------|----------|
|         |                             | MATP1220 | MOTP1220 | MATP1920 | MDTP2510 | MDTP2520 | MGTP0615 | MGTP0915 |
| 1       | ROLLER GUIDE SET            | SKRG1220 | SKRG1220 | SKRG1920 | SKRG1920 | SKRG2520 | SKRG0615 | SKRG0915 |
| 2       | SWIVEL ASSEMBLY             | RHA59s   | RHA59S   | RHA39s   | RHA49S   | RHA49S   | RHA09S   | RHA19SG  |
| 3       | SWIVEL SEAL SET (not shown) | RHA36s   | RHA36S   | RHA60s   | RHA50S   | RHA50S   | RHA10S   | RHA20SG  |
| 4       | SPRING DRUM ASSEMBLY        | SKSP1220 | SKSP1220 | SKSP1920 | SKSP1920 | SKSP2520 | SKSP0615 | SKSP0915 |
| 5       | LATCH SET                   | SK130s   | SK130s   | SK130s   | SK130s   | SK130s   | SK130s   | SK130s   |
| 6       | SCREW AND NUT SET           | n/a      | n/a      | n/a      | n/a      | n/a      | n/a      | n/a      |
| 7       | NUT AND BOLT                | n/a      | n/a      | n/a      | n/a      | n/a      | n/a      | n/a      |
| 8       | BOLT                        |          |          |          |          |          |          |          |
| 9       | BOLT                        |          |          |          |          |          |          |          |
| 10      | HOSE ASSEMBLY (not shown)   | HPW41S   | HPA41S   | HPW61S   | HPA61S   | HPA51S   | HPA11S   | HPA21SG  |
| 11      | HOSE STOPPER (not shown)    | RHA42s   | RHA42S   | RHA62S   | RHA62S   | RHA52S   | RHA12S   | HPA22SG  |

### Twin pedestal reels (Bare reels)

| Item no | DESCRIPTION                 |          |           |           |          |          |
|---------|-----------------------------|----------|-----------|-----------|----------|----------|
|         |                             | MGTP0915 | MRTP1320N | MRTP2520N | SSR1320N | SSR2520N |
| 1       | ROLLER GUIDE SET            | SKRG0915 | SKRG1220  | SKRG2520  | SKSG1220 | SKSG2520 |
| 2       | SWIVEL ASSEMBLY             | RHA19SG  | RHA59s    | RHA49s    | RSA39s   | RSA49s   |
| 3       | SWIVEL SEAL SET (not shown) | RHA20SG  | RHA36s    | RHA50s    | RHA36s   | RHA50s   |
| 4       | SPRING DRUM ASSEMBLY        | SKSP0915 | SKSP1220  | SKSP2520  | RAS36s   | RAS60s   |
| 5       | LATCH SET                   | SK130s   | SK130s    | SK130s    | SK130s   | SK130s   |
| 6       | SCREW AND NUT SET           | n/a      | n/a       | n/a       | n/a      | n/a      |
| 7       | NUT AND BOLT                | n/a      | n/a       | n/a       | n/a      | n/a      |
| 8       | BOLT                        |          |           |           |          |          |
| 9       | BOLT                        |          |           |           |          |          |
| 10      | HOSE ASSEMBLY (not shown)   | HPA21SG  | n/a       | n/a       | n/a      | n/a      |
| 11      | HOSE STOPPER (not shown)    | HPA22SG  | RHA42S    | RHA52S    | RHA42s   | RHA52s   |

## Spare Part Diagram

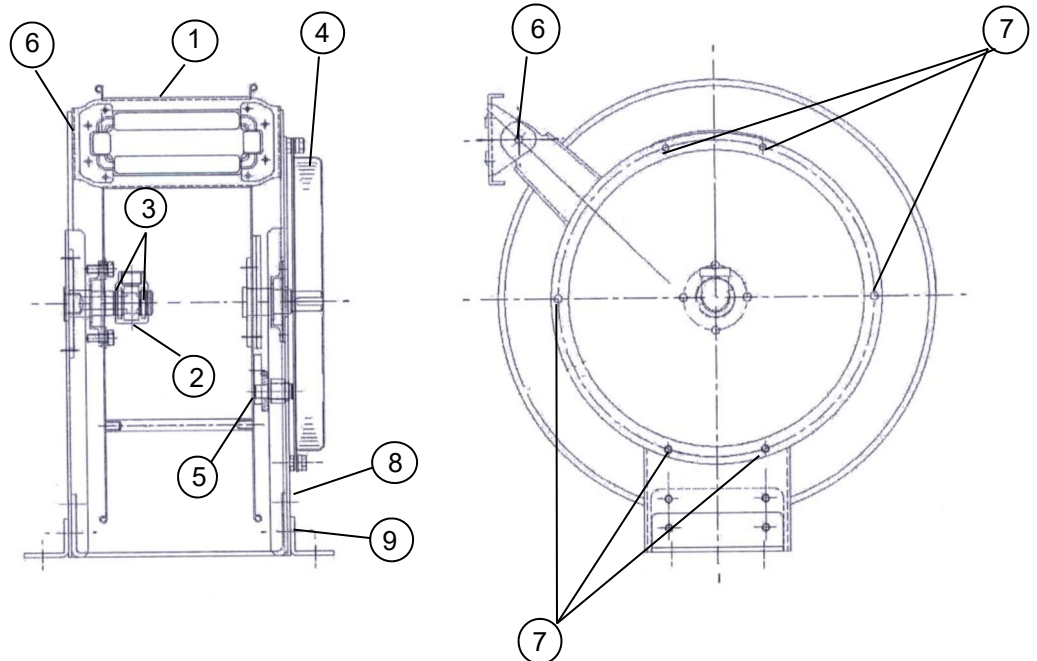

Macnaught Pty Limited  
ABN 66 000 075 785

41-49 Henderson Street  
Turrella NSW 2205 Sydney Australia  
Postal Address PO Box 90  
Amcliffe NSW 2205 Sydney Australia

T: +61 2 9567 0401  
F: +61 2 9597 7773  
W:

#### Note:

This product should be disposed of according to all applicable local and national government environment regulations and guidelines.

