



**LUBE
Control**

Lube Control Pty Ltd

**FCM3800-02 / FCD3815-02
FRM3800-02 / FRD3815-02**

F Series Heavy Duty Hose Reels

Introduction

Thank you for purchasing F-series Heavy Duty Diesel Reel.

Description

Your Retractable F-series reel has been manufactured and constructed using high quality materials.

Important



CAUTION

PLEASE READ THIS SAFETY INFORMATION CAREFULLY BEFORE USE.

Please read and retain this instruction manual to assist you in the operation and maintenance of this product.

'CAUTIONS' are listed throughout this manual to advise of actions that may cause personal injury or damage to your equipment.

Never exceed the pressure rating of any component in the system.

Before operation check hoses for signs of wear, leaks or loose fittings. Tighten all fluid connections regularly and replace weak or damaged hose.

Check equipment daily for any leaks or damage. Repair or replace worn or damaged items immediately with genuine replacement parts.

DO NOT attempt to stop leaks with your hand, body glove or rag.

If accidental injection or injury should occur, seek IMMEDIATE emergency medical attention.

RETRACTA®
by macnaught



CAUTION

Before attempting any maintenance or repairs of this product, carefully release the fluid pressure, before disconnecting the reel, failure to do this may cause injury

To prevent injury or damage occurring, do not let go of the hose during rewinding.

Installation

- 1) Using the appropriate hardware, bolt the frame base of the reel to the desired location (See *Drilling Template*). Ensure the mounting is strong enough to support the weight of the reel.
- 2) Pull out hose to check spring tension and adjust if required (See *Adjusting Spring Tension*)
- 3) Securely connect the fluid supply line to the reel inlet on the side of the reel.
- 4) Securely connect the desired hose-end attachment to the hose outlet.

Note: Thread sealant may be required

- 4) Turn on system and check for any leaks or damage before use. Repair or reseal if required



5) It is strongly recommended that isolation valves be incorporated in the fluid system to facilitate maintenance

Hose Installation Procedure

Remove Hose Assembly

- 1) Turn off and disconnect the supply to reel and release hose line pressure.
- 2) Pull out approximately 2m (6ft) of hose and allow the drum to latch.
- 3) Remove the outlet nozzle, gun or tool and hose stopper. Unlatch the reel and carefully allow the hose to slowly rewind until there is no spring tension remaining.
- 4) Manually unwind the hose assembly from the drum. Carefully disconnect and remove the hose from swivel assembly.

Fit Hose New Assembly

- 1) Connect your new hose assembly to the swivel assembly.
- 2) Manually rotate the drum assembly (away from the roller guides) and manually recoil the hose onto the drum.
- 3) Add tension to the reel by carefully rotating the drum and hose assembly (towards the roller guides) 4 complete turns, slide the hose through the roller guides and allow the reel to latch.
- 4) Fit the hose stopper at the appropriate distance to the end of the hose. Pull the hose to release the drum latch, and slowly allow the hose to slowly rewind onto the reel.
- 4) Check for any leaks on initial start up.
(Reseal connections if required)

Maintenance

Adjusting Spring Tension

- 1) **Increase tension** - pull out approximately 2m (6ft) of hose and allow the drum to latch.
- Decrease tension** - pull minimal hose and allow the drum to latch

- 2) Remove hose stopper from hose, and feed hose back through the guide.

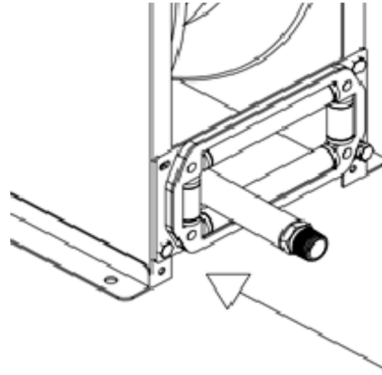

- 3) Wrap the hose an additional loop around the drum to increase tension or un-wrap a loop to decrease tension.

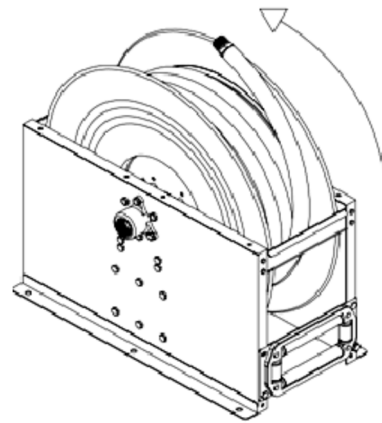

Increase tension

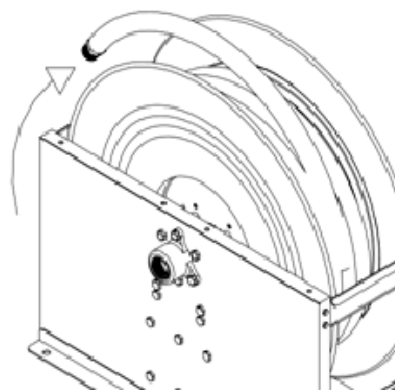

Decrease tension

- 4) Re-insert hose through guide, and install stopper onto the hose end.
- 5) Unlatch the Drum and check tension. Repeat 1-5 if necessary



Maintenance

Replace Swivel Seals

- 1) Remove the six bolts from the swivel body casting on the reel inlet
- 2) Carefully remove the old o'ring and backup ring

Note: Be careful not to score the seal groove

- 3) Fit a new set of swivel seals.
- 4) Lubricate the seals with a light mineral oil
- 5) Carefully slide the swivel body back into place and then replace the 6 swivel bolts
- 6) Check for leaks after re-connecting the reel

Spring Canister Removal

- 1) Pull out the hose approximately 1m (3ft) and latch the reel.
- 2) Remove the outlet nozzle, gun or tool and hose stopper.
- 3) Carefully unlatch the reel and firmly hold the drum. Allow the drum to slowly unwind until it stops and no spring tension remains.
- 4) Carefully remove the nuts and washers located around the drum assembly.



CAUTION

There is a large spring inside which can cause severe injury if not handled correctly.

- 5) Carefully remove both the front and back spring canister covers together as an assembly.
- 6) Carefully sit the drum canister down so as the flat inner plate flat is facing up.
- 7) Carefully remove the flat inner plate to expose the spring.
- 8) Inspect and replace the complete drum assembly if the spring is found to be damaged.



CAUTION

DO NOT under any circumstances remove the spring from the canister.

Spring Canister Replacement

- 1) Slide the flat inner plate over the shaft on the reel.
 - 2) Check the correct orientation of the spring locating boss. Remove the boss from the middle of the spring canister and slide the boss onto the shaft on the reel.
 - 3) Carefully hold the centre of the spring up in the middle of the drum, at the same time slide the drum assembly over the centre boss on the shaft.
- Note:** The spring will automatically locate itself into the centre boss when you re-tension the reel.
- 4) Replace all the washers and nuts around the outside of the drum assembly and securely tighten.
 - 5) Turn the drum anti-clockwise until you feel the spring start to tension, then turn the drum three complete turns and latch the drum.
 - 6) Feed the hose through the hose guide, fit the hose stopper, then unlatch the drum. The hose stopper should now sit snugly against the hose guide.



Diagram and Part List

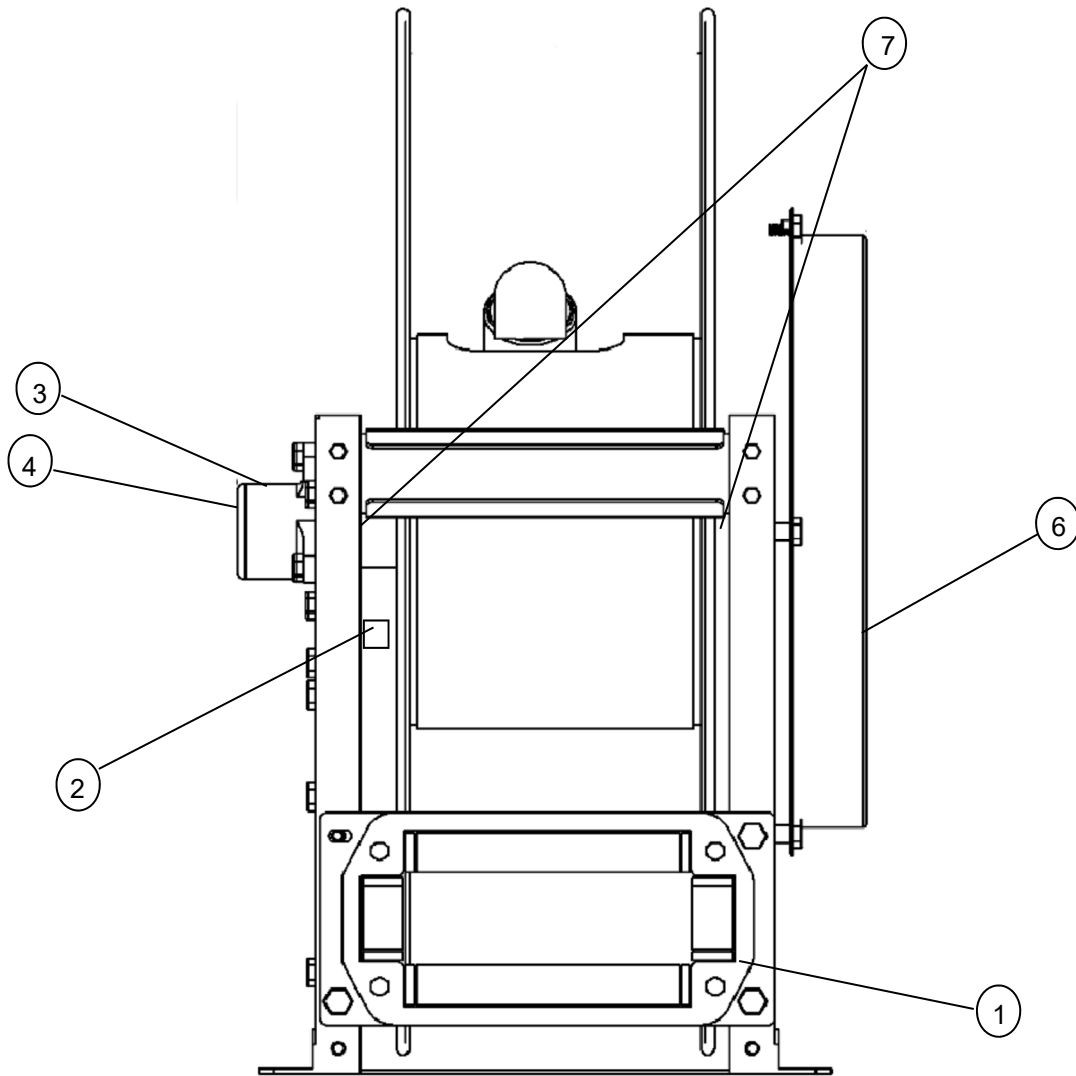

Order for replacement			
Item no	Part or Set	No off	Description
1	SK245s	1	Roller mouth assembly
2	SK243s	1	Latch Set
3	SK240s	1	Swivel Assembly
4	SK241s	1	Swivel Seal Set
5	RHA72s	1	Hose Stopper (not shown)
6	SK152s	1	Spring Cannister Assembly
7	SK244s	2	Bearing Set



Troubleshooting

<i>Problem</i>	<i>Cause</i>	<i>Remedy</i>
Hose does not fully retract	Outlet nozzle, gun or tool is too heavy	Add spring tension (See "Adjust Spring Tension")
	Spring requires re-tensioning	Add spring tension (See "Adjust Spring Tension")
	Replacement hose is too long	Fit correct length hose (Refer to Hose Specifications")
Hose does not retract at all	Spring has broke or has lost tension	Replace spring canister is required
Reel does not latch	Incorrect operation	Reel latches on first, second or third 'click'. After the third click reel automatically rewinds
	Latch assembly is worn	Replace the latch assembly
Fluid leaks from the swivel	Swivel seals are worn	Replace swivel seals (See "Replacement of Swivel Seals")



**LUBE
Control**

Lube Control Pty Ltd

Dimensional Diagrams

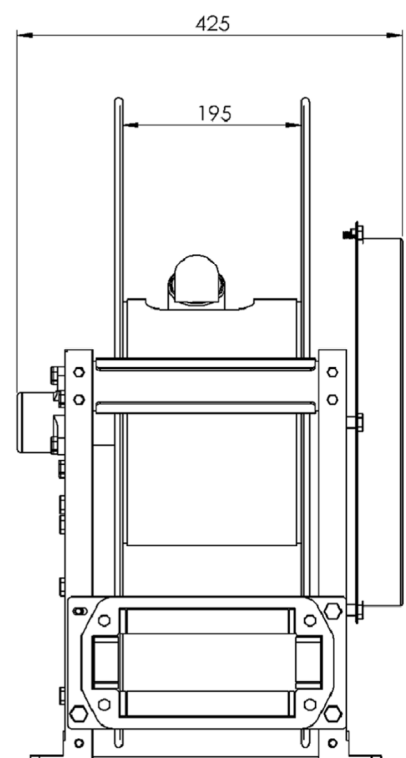
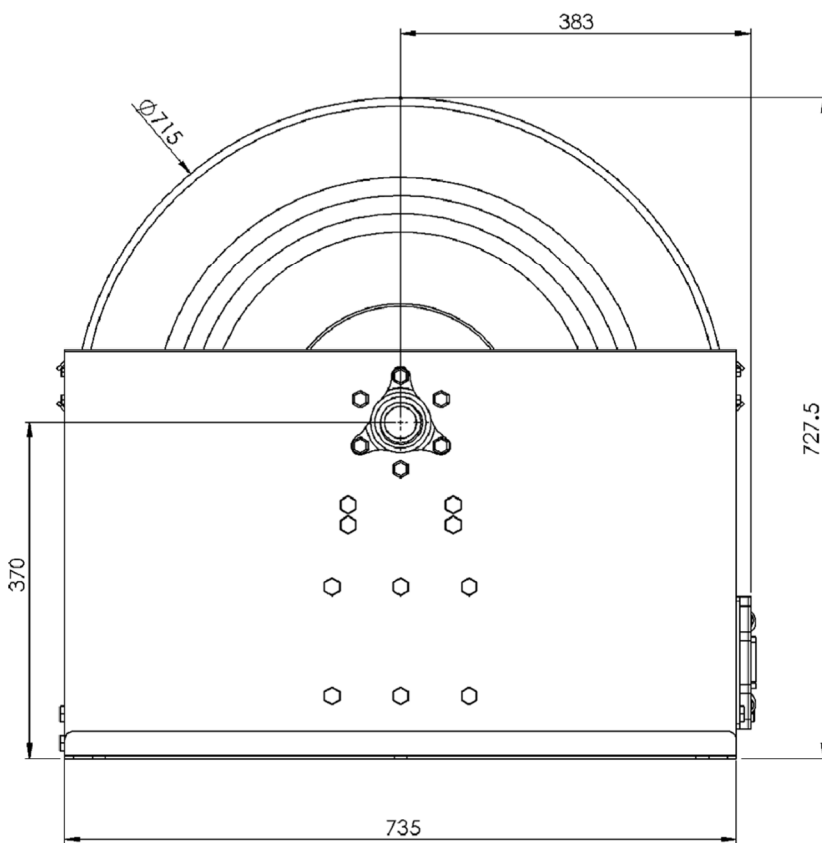
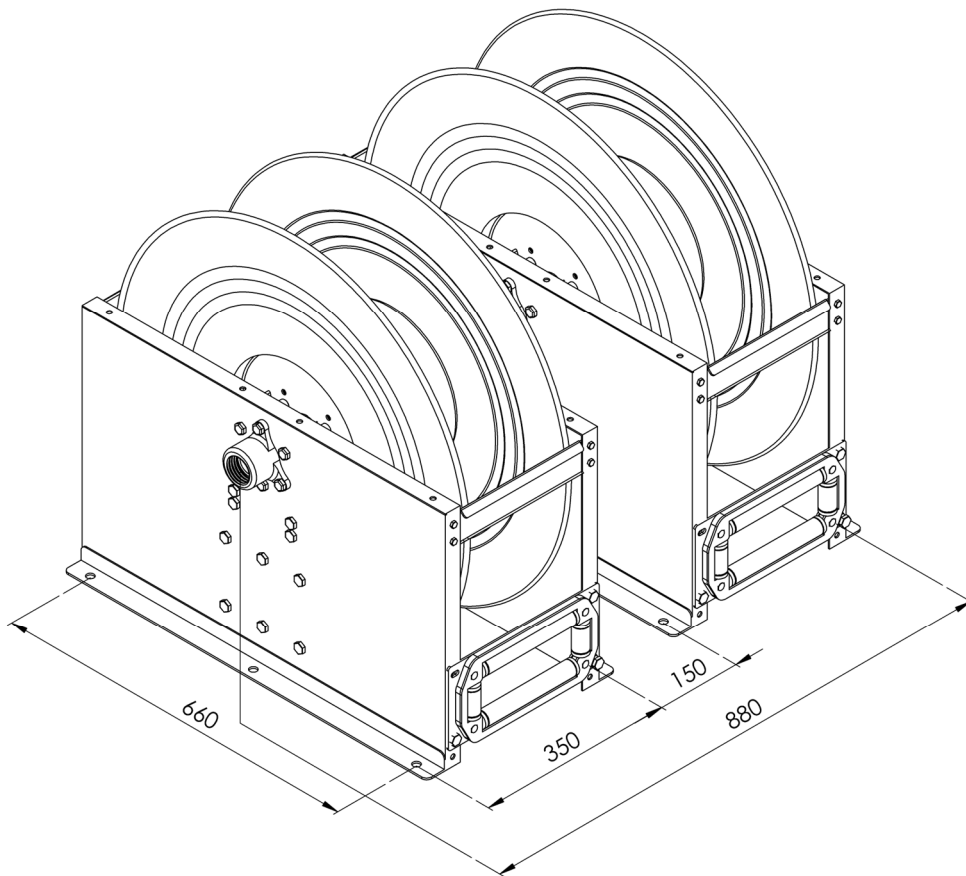



Drilling Template

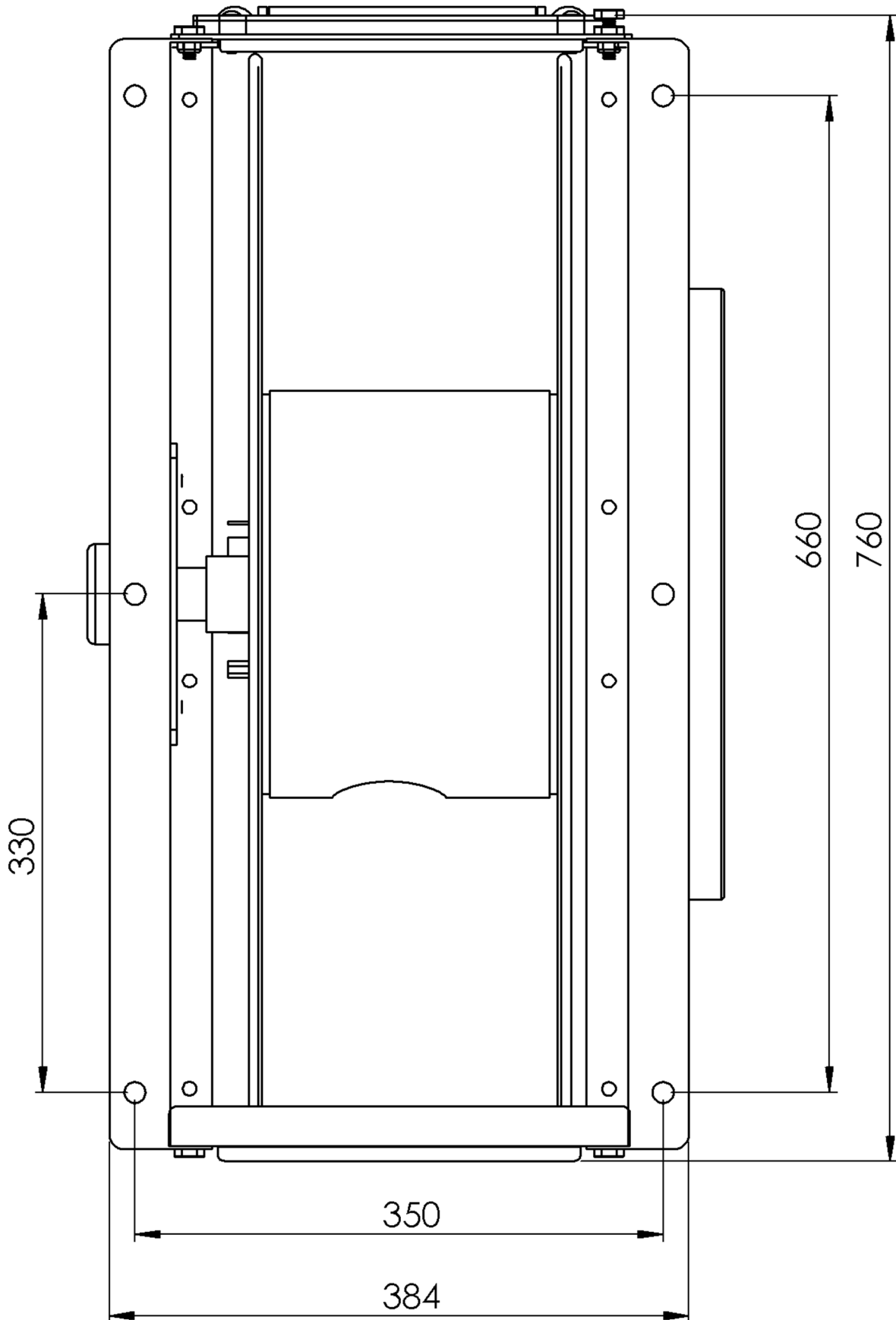

Note: Drawing Not To Scale



**LUBE
Control**

Lube Control Pty Ltd

Reel Specifications

	FCM3800-02 / FRM3800-02	FCD3815-02 / FRD3815-02
Nominal Size	1 - 1/2" (38mm) ID	1 - 1/2" (38mm) ID
Fluid Type	-	Oil/ Diesel
Working Pressure	500 psi	500 psi
Shaft Material	Stainless Steel	Stainless Steel
Housing Material	Zinc Plated Brass	Zinc Plated Brass
O-Ring Material	Viton	Viton
Reel Inlet	1 - 1/2" NPT (F)	1 - 1/2" NPT (F)
Reel Swivel Outlet	1 - 1/2" NPT (F)	-
Hose type	-	Wire Reinforced Rubber (SAE 100R1)
Length	15m capacity	15m
Hose Outlet	-	1 - 1/2" NPT (M)
Included Feeder Hose	No	No



Macnaught Pty Limited
ABN 66 000 075 785

41-49 Henderson Street
Turrella NSW 2205 Sydney Australia
Postal Address PO Box 90
Amcliffe NSW 2205 Sydney Australia

Note:

This product should be disposed of according to all applicable local and national government environment regulations and guidelines.



**For Warranty Terms and Conditions see macnaught.com.au
For a list of Australian Service Centres see macnaught.com.au**