

**FHM1900-01**  
**FHO1915-01**  
**FHA1220-01**

**RETRACTA®**  
by macnaught

## F Series Heavy Duty Hose Reels

### Introduction

Thank you for purchasing the F-Series Heavy duty hose reel

### Description

Your Retractable F-series reel has been manufactured and constructed using high quality materials.

### Important



#### CAUTION

**PLEASE READ THIS SAFETY INFORMATION CAREFULLY BEFORE USE.**

Please read and retain this instruction manual to assist you in the operation and maintenance of this product.

'CAUTIONS' are listed throughout this manual to advise of actions that may cause personal injury or damage to your equipment.

Never exceed the pressure rating of any component in the system.

Before operation check hoses for signs of wear, leaks or loose fittings. Tighten all fluid connections regularly and replace weak or damaged hose.

Check equipment daily for any leaks or damage. Repair or replace worn or damaged items immediately with genuine replacement parts.

**DO NOT attempt to stop leaks with your hand, body glove or rag.**

**If accidental injection or injury should occur, seek IMMEDIATE emergency medical attention.**



#### CAUTION

**Before attempting any maintenance or repairs of this product, carefully release the fluid pressure, before disconnecting the reel, failure to do this may cause injury**

**To prevent injury or damage occurring, do not let go of the hose during rewinding.**

### Installation

- 1) Using the appropriate hardware, bolt the frame base of the reel to the desired location (See *Drilling Template*). Ensure the mounting is strong enough to support the weight of the reel.
- 2) Pull out hose to check spring tension and adjust if required (See *Adjusting Spring Tension*)
- 3) Securely connect the fluid supply line to the reel inlet on the side of the reel.
- 4) Securely connect the desired hose-end attachment to the hose outlet.

**Note:** Thread sealant may be required

- 4) Turn on system and check for any leaks or damage before use. Repair or reseal if required



### Mounting Options

- Truck bed
- Wall (Max 4 meter above the floor)
- Ceiling (Max 4 meter above the floor)

#### Guide arm positions:

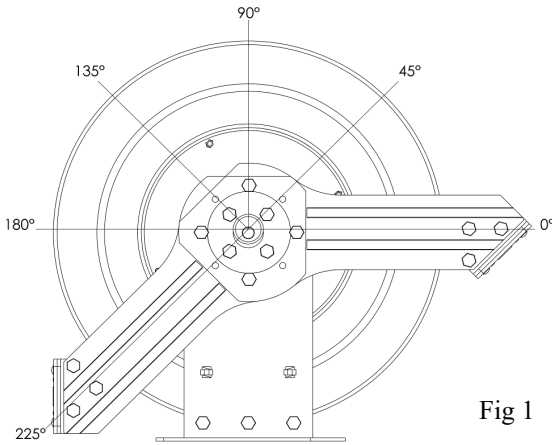

Fig 1

**Note: Hose must always pull straight off the drum as pictured in fig 2 below**

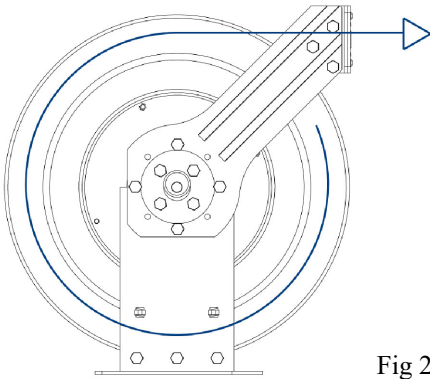

Fig 2

**Note: Incorrect hose orientation pictured in Fig 3 below**

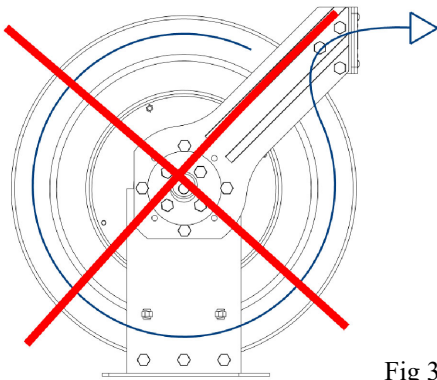

Fig 3

### Hose Installation Procedure

#### Remove Hose Assembly

- 1) Turn off and disconnect the supply to reel and release hose line pressure.
- 2) Pull out approximately 2m (6ft) of hose and allow the drum to latch.
- 3) Remove the outlet nozzle, gun or tool and hose stopper. Unlatch the reel and carefully allow the hose to slowly rewind until there is no spring tension remaining.
- 4) Manually unwind the hose assembly from the drum. Carefully disconnect and remove the hose from swivel assembly.

#### Fit Hose Assembly

- 5) Connect your new hose assembly to the swivel assembly.
- 6) Manually rotate the drum assembly (away from the roller guides) and manually recoil the hose onto the drum.
- 7) Add tension to the reel by carefully rotating the drum and hose assembly (towards the roller guides) 4 complete turns, slide the hose through the roller guides and allow the reel to latch.
- 8) Fit the hose stopper to the hose end, release pull the hose to release the drum latch, and slowly allow the hose to slowly rewind onto the reel.

### Maintenance

#### Adjust Spring Tension

- 1) Allow the hose to fully retract with the hose stopper sitting against the mouth of the reel.
- 2) Loosen (but do not remove) the 4 bolts located on the side of the reel.
- 3) Insert M12 hex allen key and hold it firmly before removing the 4 bolts. When the bolt is removed, the spring tension will transfer to the hex key.

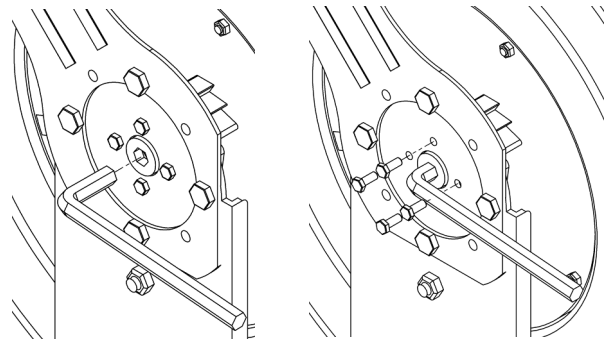



## Maintenance

Turn the hex key clockwise (against hose roll out) to increase tension.

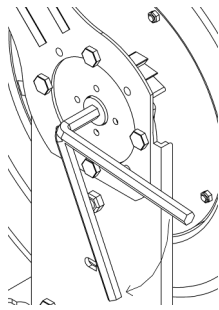

Increase Tension

Turn the hex key counter-clockwise (with hose roll out) to decrease tension.

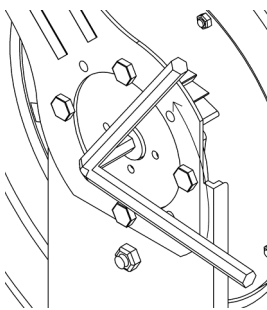

Decrease Tension

**Note:** The spring tension are adjustable at 90° intervals

- 5) replace the 4 bolts to complete the adjustment.
- 6) Unlatch the Drum and check tension.  
Repeat (1 - 5) if necessary

### Replace Swivel Seals

- 1) Turn off and disconnect the supply to reel and release hose line pressure.
- 2) Remove the supply line to the reel.
- 3) Remove the outlet nozzle, gun or tool and hose stopper. Unlatch the reel and carefully allow the hose to slowly rewind until there is no spring tension remaining.
- 4) Remove roller arm (1)
- 5) Carefully remove the shaft nut (2)
- 6) Remove the side pedestal from the reel (3)

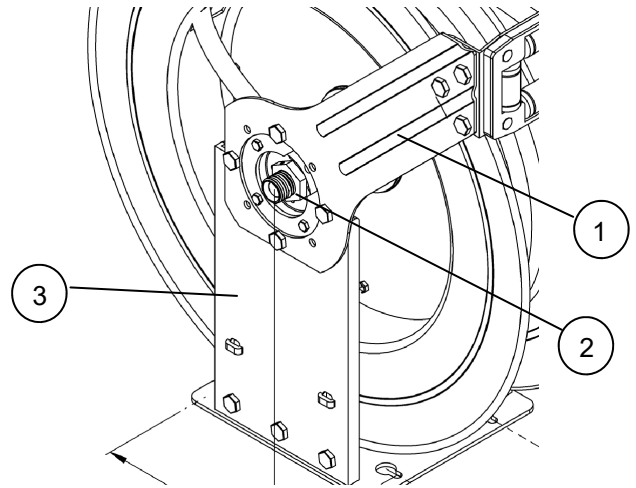

7) Remove the circlip retaining the swivel body

8) Remove the swivel body from the shaft.

**Note: Remove the hose from swivel body if required.**

9) Remove the old swivel seals, then carefully fit your new set of seals

10) Lubricate swivel seals with oil, and carefully slide swivel body onto the swivel shaft, then fit the circlip

11) The rest of the re-assembly is a direct reversal of the disassembly procedure.



Diagram and Part List

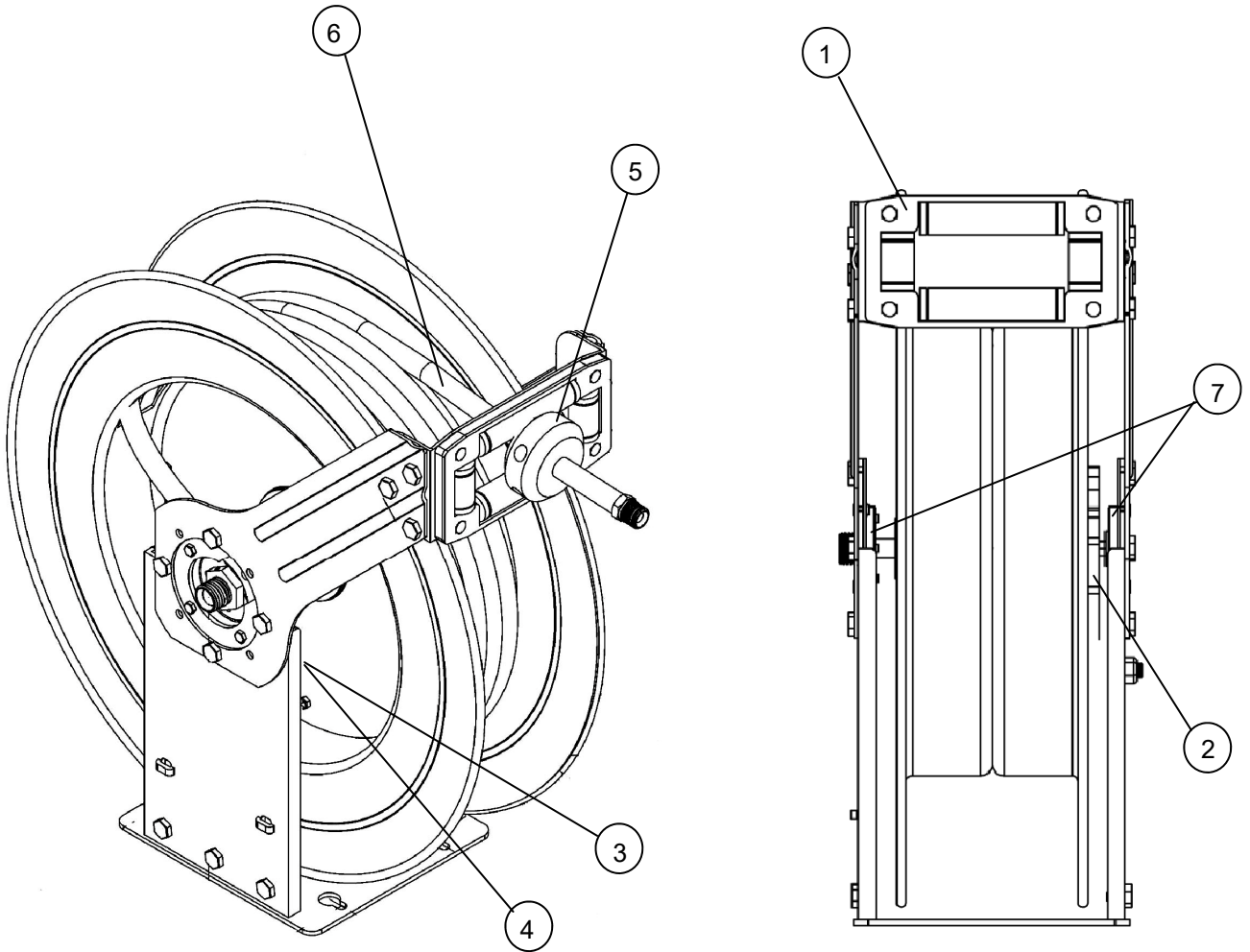

Order for replacement			
Item no	Part or Set	No off	Description
1	SK225s	1	Roller mouth assembly
2	SK223s	1	Latch Set
3	SK220s	1	Swivel Assembly
4	SK221s	1	Swivel Seal Set
5	RHA62s	1	Hose Stopper
6	RH1915HPs	1	Hose Assembly
7	SK224s	2	Bearing Set



## Troubleshooting

<i>Problem</i>	<i>Cause</i>	<i>Remedy</i>
Hose does not fully retract	Outlet nozzle, gun or tool is too heavy	Add spring tension (See “Adjust Spring Tension”)
	Spring requires re-tensioning	Add spring tension (See “Adjust Spring Tension”)
	Replacement hose is too long	Fit correct length hose (Refer to Hose Specifications”)
Hose does not retract at all	Spring has broke or has lost tension	Replace spring canister is required
Reel does not latch	Incorrect operation	Reel latches on first, second or third ‘click’. After the third click reel automatically rewinds
	Latch assembly is worn	Replace the latch assembly
Fluid leaks from the swivel	Swivel seals are worn	Replace swivel seals (See “Replacement of Swivel Seals”)



**LUBE**  
Control

Lube Control Pty Ltd

Dimensional Diagrams

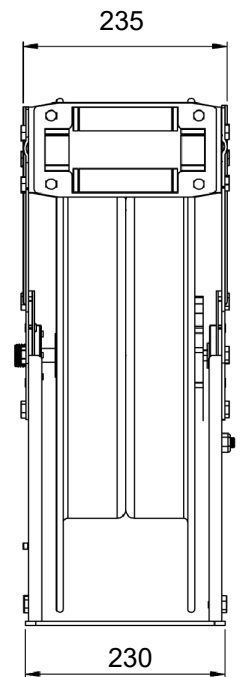
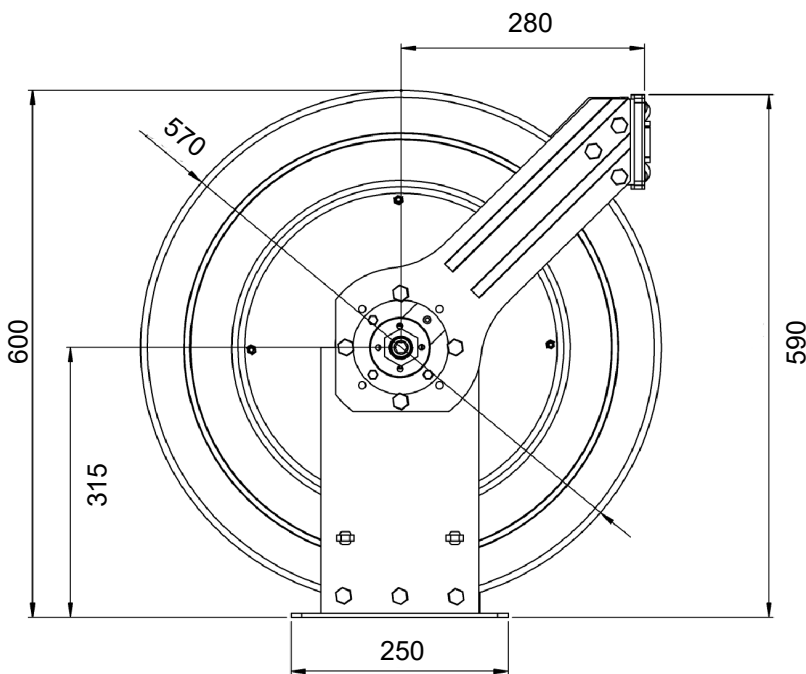
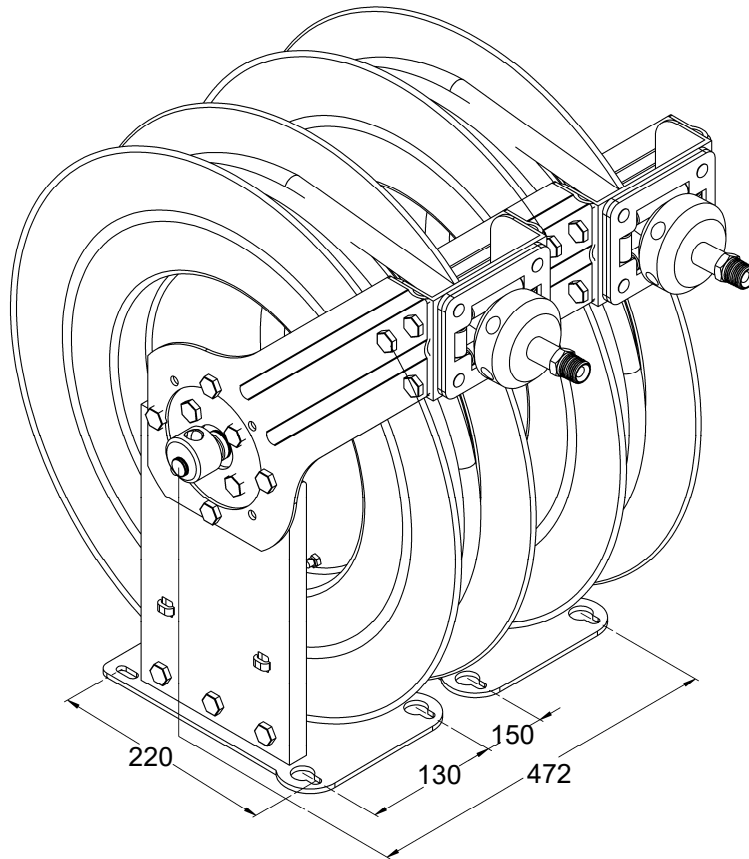



**LUBE**  
Control

Lube Control Pty Ltd

Drilling Template

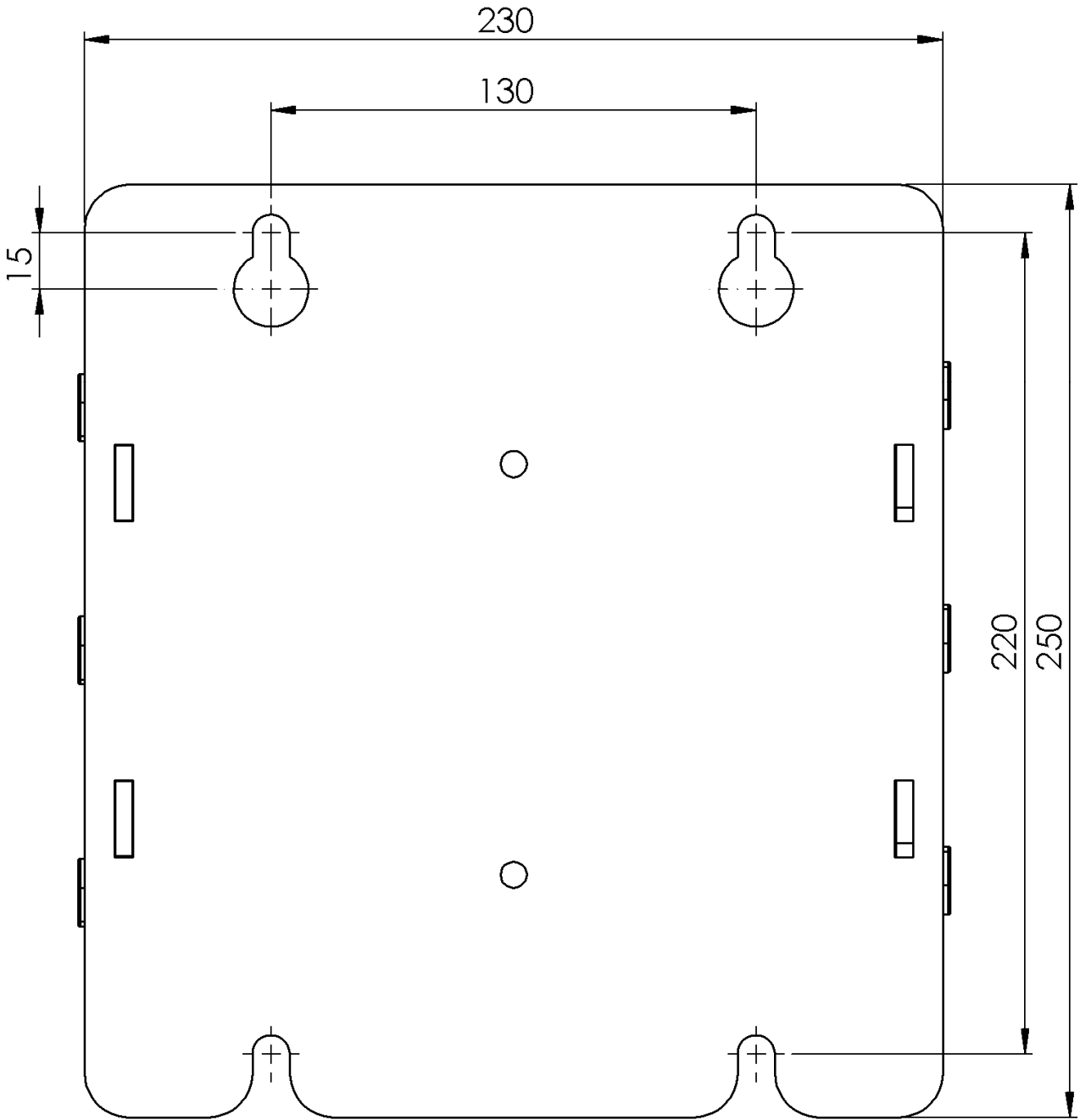

Note: Drawing Not To Scale

Reel Specifications

	<b>FHM1900-01</b>	<b>FHO1915-01</b>	<b>FHA1220-01</b>
<b>Nominal Size</b>	3/4" (19mm) ID	3/4" (19mm) ID	1/2" (12mm) ID
<b>Fluid Type</b>	-	Oil/ Diesel	Air/Water
<b>Working Pressure</b>	1450 psi	1450 psi	250 psi
<b>Shaft Material</b>	Stainless Steel	Stainless Steel	Stainless Steel
<b>Housing Material</b>	Zinc Plated Brass	Zinc Plated Brass	Zinc Plated Brass
<b>O-Ring Material</b>	Viton	Viton	Viton
<b>Reel Inlet</b>	3/4" BSP (F)	3/4" BSP (F)	1/2" BSP (F)
<b>Reel Swivel Outlet</b>	3/4" BSP (F)	-	-
<b>Hose type</b>	-	Wire Reinforced Rubber (SAE 100R2)	Reinforced PVC
<b>Length</b>	15m capacity	15m	20m
<b>Hose Outlet</b>	-	3/4" BSP (M)	1/2" BSP (M)
<b>Included Feeder Hose</b>	No	Yes	Yes



Macnaught Pty Limited  
ABN 66 000 075 785

41-49 Henderson Street  
Turrella NSW 2205 Sydney Australia  
Postal Address PO Box 90  
Amcliffe NSW 2205 Sydney Australia

**Note:**

This product should be disposed of according to all applicable local and national government environment regulations and guidelines.

