

# RETRACTA<sup>®</sup>

by macnaught

---

## R3 SERIES HOSE REELS



R3-Series\_RET\_IM\_2509\_SS\_V3

# RETRACTA<sup>®</sup>

by macnaught



**WARNING:**

Read carefully and understand all **INSTRUCTIONS** before operating. Failure to follow the safety rules and other basic safety precautions may result in serious personal injury. Save these instructions in a safe place and on hand so they can be read when required.



**WARNING:**

The warnings, cautions, and instructions discussed in this instruction manual cannot cover all possible conditions or situations that could occur. It must be understood by the operator that common sense and caution are factors that cannot be built into this product but must be supplied by the operator.



**CAUTION:**

Make sure the line pressure does not exceed the rated operating pressure of your model hose reel; refer to the Specifications section.



**CAUTION:**

Exposure of the skin directly to pressurised air or fluid could result in severe bodily injury.



**CAUTION:**

Always close the supply of fluid / gas to the reel and release the line pressure / vent the hose before carrying out any maintenance on the reel.

## GENERAL SAFETY

The following general warnings should be observed when installing, operating or maintaining hose reel equipment.

1. Keep the work area clean and dry. Damp or wet work areas can result in injury.
2. Keep children away from the work area. Do not allow children to handle this product.
3. Use reel in well-ventilated areas if toxic or flammable fluids / gases are in use.
4. The operator should wear appropriate protection equipment to protect against personal injury.
5. Do not let go of the hose when rewinding, always hold and drive the hose while rewinding it, to avoid damage to the machine, surrounding objects or injuries to people.
6. Do not attempt to stop leaks with your hand or body. Caution should be observed against burning due to hot water temperature when using hot water reels.
7. Do not overreach. Always keep proper footing and balance to prevent tripping, falling, back injury, etc.
8. Do not use the equipment when tired or under the influence of drugs, alcohol, or medication. A moment of inattention while operating this equipment may result in serious personal injury.
9. Use the right tool for the job. Do not attempt to force small equipment to do the work of larger industrial equipment. There are certain applications for which this equipment was designed. It will do the job better and more safely at the capacity for which it was intended. Do not modify this equipment, and do not use this equipment for a purpose for which it was not intended.
10. Only use compatible fluids / gases with this reel. (Refer to compatible fluids / gases in the Technical Details)
11. Do not exceed the maximum working pressure for this reel. (Refer to the Technical Details)
12. Check for damaged parts. Before using this product, carefully check that it will operate properly and perform its intended function. Check for damaged parts and any other conditions that may affect the operation of this product. DO NOT use damaged equipment.
13. It is recommended that leak tests on all equipment be carried out at least once a month, or when replacing any supply equipment.
14. Always close the supply of fluid / gas to the reel and release the line pressure / vent the hose before carrying out any maintenance on the reel.

## TECHNICAL DETAILS

### SPECIFICATIONS

**1. Note:** The part numbers listed below use the # symbol to represent the case colour. Example: AW420B-01 is represented in the table below by AW420#-01.

**2. Note:** \*Part numbers that start with RY have the same specifications as part numbers that start with RO in the table.

Type	Compressed Air / Water						
Part Number	*RO320#-01	*RO365#-02	*RO420#-01	*RO465#-02	AR320#-01	AR415#-01	AR420#-01
RACR Part Number	*ROC320#-01	*ROC365#-02	*ROC420#-01	*ROC465#-02	N/A		
Hose Size (ID)	10mm (3/8")		12mm (1/2")		10mm (3/8")	12mm (1/2")	
Hose Length	20m (65ft)				20m	15m	20m
Hose Colour	Orange				Yellow		
Reel Inlet	3/8" BSPT (F)	3/8" NPT (F)	3/8" BSPT (F)	3/8" NPT (F)	3/8" BSPT (F)		
Hose Outlet	1/4" BSPT (M)	1/4" NPT (M)	3/8" BSPT (M)	3/8" NPT (M)	1/4" BSPT (M)	3/8" BSPT (M)	
Hose Material	RetractaFLEX Hybrid Polymer				Premium Reinforced PVC		
Working Pressure	300 psi				275 psi		
Max Temperature	60°C						

\*RO part numbers are equivalent specifications to RY part numbers. E.g. RO320B-01 = RY320B-01

Type	Compressed Air / Water							
Part Number	AW315#-01	AW320#-01	AW325#-01	AW365#-02	AW415#-01	AW420#-01	AW425#-01	AW465#-02
RACR Part Number	N/A							
Hose Size (ID)	10mm (3/8")				12mm (1/2")			
Hose Length	15m	20m	25m	65ft	15m	20m	25m	65ft
Hose Colour	Blue							
Reel Inlet	3/8" BSPT (F)			3/8" NPT (F)	3/8" BSPT (F)			3/8" NPT (F)
Hose Outlet	1/4" BSPT (M)			1/4" NPT (M)	3/8" BSPT (M)			3/8" NPT (M)
Hose Material	Hybrid Polymer							
Working Pressure	250 psi							
Max Temperature	60°C							



Type	Water								
Part Number	DR418#-03	DR460#-05	DR425#-03	DR482#-05	HW415R-01	HW420R-01	HW465R-02	CW420B-01	HP320R-01
RACR Part Number	N/A					HWC420R-01	HWC465R-02	CWC420B-01	
Hose Size (ID)	12mm (1/2")				12mm (1/2")			12mm (1/2")	10mm (3/8")
Hose Length	18m (60ft)		25m (82ft)		15m	20m (65ft)		20m	20m
Feed Hose Length	2m (6ft)				N/A			N/A	N/A
Hose Colour	Green				White			White	Black
Feed Hose Inlet	1/2" Quick Connector (F)	3/4"-11 1/2" GHT (F)	1/2" Quick Connector (F)	3/4"-11 1/2" GHT (F)	N/A			N/A	N/A
Reel Inlet	3/4" BSP (M)	3/4" BSP (M)	3/4" BSP (M)	3/4" BSP (M)	1/2" BSPT (F)		1/2" NPT (F)	1/2" BSPT (F)	3/8" BSPT (F)
Hose Outlet	1/2" Quick Connector (F)	3/4"-11 1/2" GHT (M)	1/2" Quick Connector (F)	3/4"-11 1/2" GHT (M)	1/2" BSP (M)		1/2" NPT (M)	1/2" Brass Quick Connector (F)	3/8" BSPT (M)
Hose Material	RetractaFLEX Hybrid Polymer				High Temperature Chemical Resistant PVC			Premium Reinforced PVC	2 Layer Wire Braid Synthetic Rubber
Working Pressure	150 psi				290 psi at 20°C			150 psi	3000 psi
					100 psi at 80°C				
Max Temperature	60°C				85°C			60°C	95°C

Type	Oil	Grease	Weedicide / Pesticide	F.R.A.S.	Oxyacetylene	Oxygen / LPG	Argon	LPG (Propane)
Part Number	OMP415B-01	GR215K-01	WD316R-01	FRAS415D-01	OA215B-04	OG215K-04	ARG220D-04	LPG220K-04
RACR Part Number	OMPC415B-01	N/A	N/A	N/A	OAC215B-04	N/A	N/A	N/A
Hose Size (ID)	12mm (1/2")	6mm (1/4")	10mm (3/8")	12mm (1/2")	Twin 5mm (3/16")	Twin 5mm (3/16")	5mm (3/16")	5mm (3/16")
Hose Length	15m	15m	16m	15m	15m	15m	20m	20m
Hose Colour	Black	Black	Black	Yellow	Red / Blue	Orange / Blue	Black	Orange
Reel Inlet	1/2" BSPT (F)	1/4" NPT (F)	3/8" BSPT (F)	1/2" BSPT (F)	Gas Thread UNF (M)	Gas Thread UNF (M)	Gas Thread UNF (M)	Gas Thread UNF (M)
Hose Outlet	1/2" BSPT (M)	1/4" BSPT (M)	1/4" BSP (M)	1/2" BSPT (M)	Gas Thread UNF (F)	Gas Thread UNF (F)	Gas Thread UNF (F)	Gas Thread UNF (F)
Hose Material	Wire Reinforced Rubber (SAE100R17)	Wire Reinforced Rubber (SAE100R2)	Chemical Resistant PVC	Reinforced PVC (F.R.A.S)	Reinforced Rubber (AS1335)	Reinforced Rubber (AS1335)	Reinforced Rubber (AS1335)	Reinforced Rubber (AS1335)
Working Pressure	1000 psi	5000 psi	250 psi	300 psi	175 psi	175 psi	200 psi	200 psi
Max Temperature	90°C	100°C	60°C	60°C	80°C	60°C	60°C	60°C

**DIMENSIONS  
REEL**

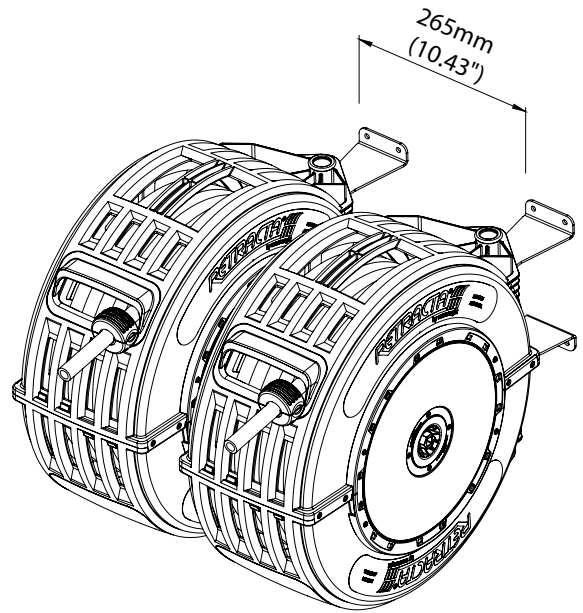
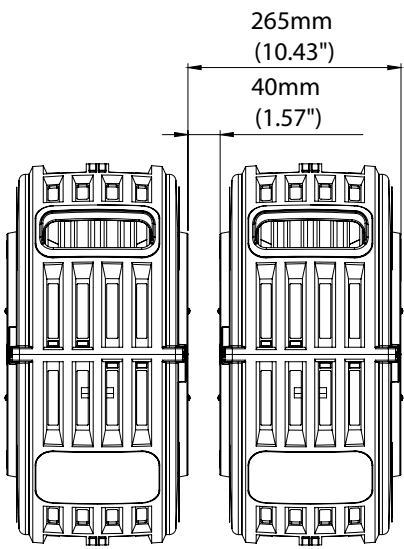
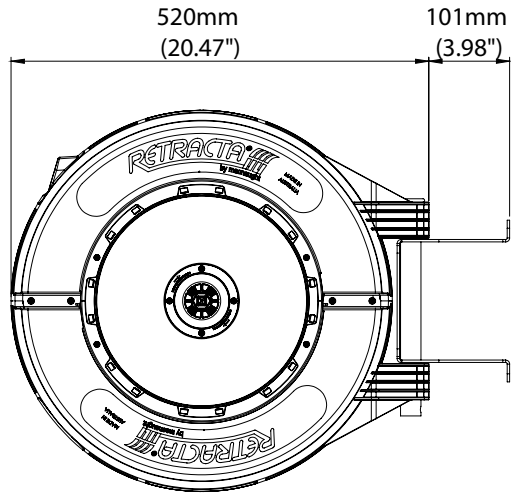
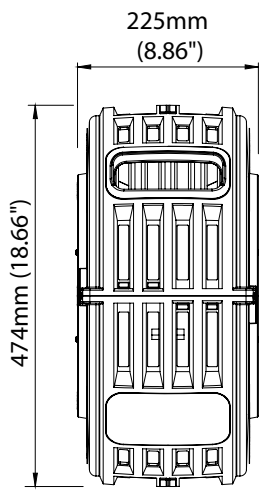

**IMPORTANT:**  
Drawings are not to scale.

## BU200 WALL BRACKET

Included as standard with all reels.

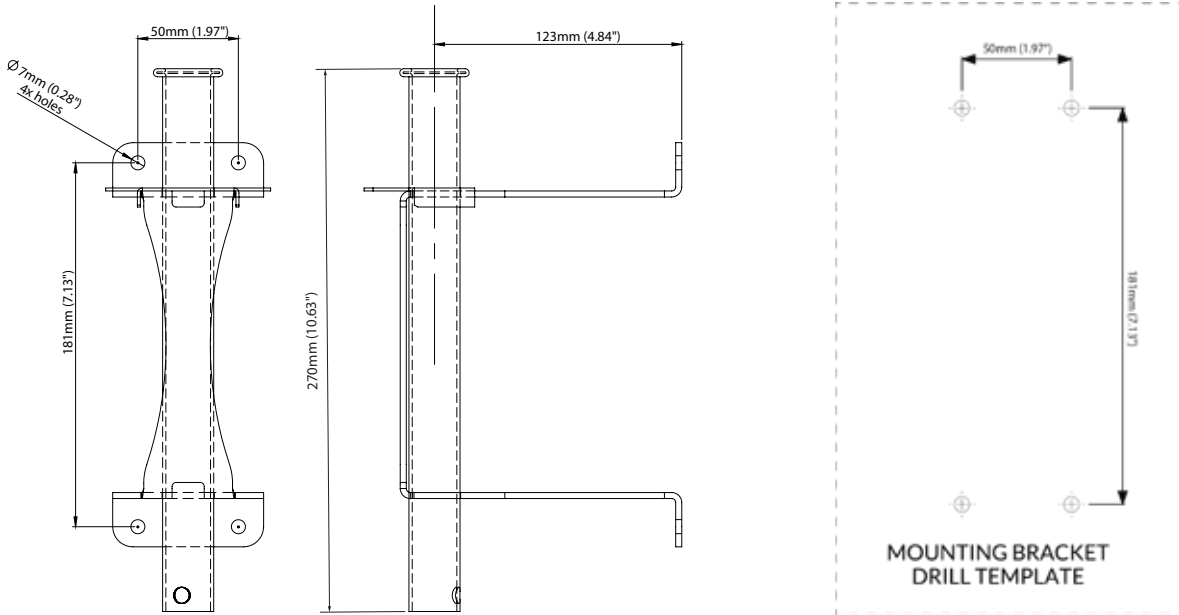

## BB200 BENCH MOUNT BRACKET

Available as an optional accessory.

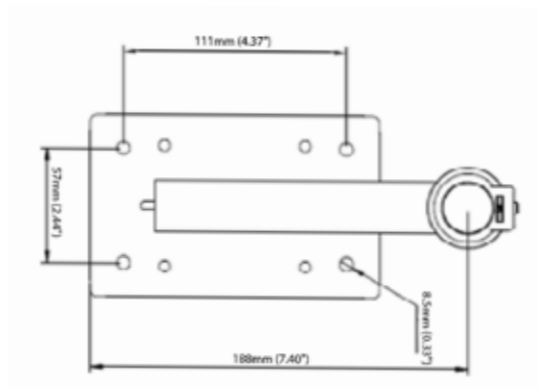
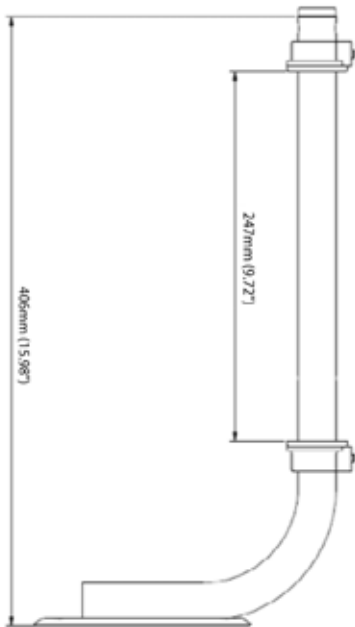

**IMPORTANT:**  
Drawings are not to scale.

## INSTALLATION PROCEDURE

### INSTALLATION



**IMPORTANT:**

**Any installation including plumbing should be carried out by a suitably qualified person carefully following the information provided in this manual and in conformance to any applicable country, state and local regulations and laws.**

1. Unpack and inspect the reel for damage. Turn by hand to check for smooth operation, pulling the hose out and recoiling it back into the reel.
2. You need to purchase suitable hardware based on the reel weight (including fluid type) and surface type on which you are mounting the reel. The mounting bracket has four 7mm diameter drilled holes for mounting on a suitable flat surface.
3. Ensure the location selected to mount the reel has adequate clearance and will not interfere with other objects.
4. For overhead mounting positions, the reel should not exceed 4.5m / 14.7 feet in height.
5. The template provided on the packaging can be used to mark holes for hardware. A copy of the template is also included in the Dimensions section of this instruction manual.
6. Using the four holes install the mounting bracket. Be sure to use appropriate hardware and tighten securely.
7. With the mounting bracket installed, the reel can now be mounted to the bracket using the Pivot Tube. To prevent the reel from swivelling in the overhead position (figure 2) use the locking bracket. See Fitting the Locking Bracket section of this instruction manual for fitting instructions.
8. Adjust the hose stopper to the desired location using an appropriate screwdriver.
9. If the spring recoil tension requires adjusting refer to "Add Spring Tension" for the correct procedure.

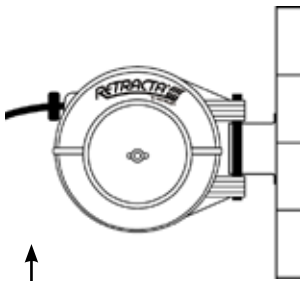

Fig.1 Wall mounting  
(max height 1.4m / 4.6ft)

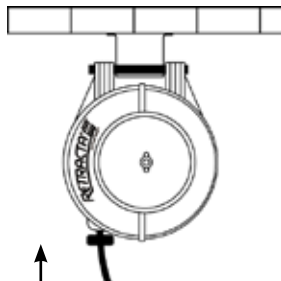

Fig.2 Overhead mounting  
(max height 4.5m / 14.7ft)

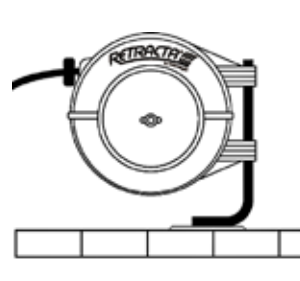

Fig.3 BB200 Bracket -  
Floor/Bench

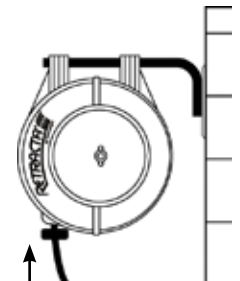

Fig.4 BB200 Bracket High  
wall mounting (max height  
4.5m / 14.7ft)

## FITTING THE LOCKING BRACKET



1. Locking bracket position out of the box.



2. Remove the pivot tube and flip over the locking bracket, placing it on top of the wall bracket.



3. Mount the reel to the wall bracket and insert the pivot tube.

## CONNECTION - FLUIDS

(COMPRESSED AIR / WATER / OIL / GREASE / WEEDICIDE / PESTICIDE / F.R.A.S.)



### IMPORTANT:

**Always connect the hose reel to the supply line with hose and couplers suitable for the fluid, pressure and temperature.**

1. Ensure an appropriate fluid shut-off valve is installed to the supply line prior to connection. This will make maintenance easier and can act as a safety valve in dangerous situations.
2. Apply Teflon tape or pipe sealant to the supply line threads, attach to reel inlet and tighten. The other end of the incoming line can now be connected to the desired supply source.
3. Apply Teflon tape or pipe sealant to the outlet fitting on the reel hose, then attach it to the desired tool, or nozzle.
4. Check connections for leakage, and also check the hose reel for correct operation. (See Operation section.)

**CONNECTION - GASES**

(OXYACETYLENE / OXYGEN & LPG / ARGON / LPG)



**IMPORTANT:**

**Only use the gas type specified for the reel in the Technical Details section of this instruction manual.**



**IMPORTANT:**

**Always connect the hose reel to the supply line with hose and couplers suitable for the gas, pressure and temperature.**



**IMPORTANT:**

**DO NOT exceed the recommended maximum gas draw-off rate from the cylinder and only operate when the cylinder is upright. Gas contained in the cylinder can escape and damage the hose, hose reel seals and other equipment.**



**CAUTION**

**Do not use pipe-fitting compounds or thread lubricants to make connections.**

1. Operation and maintenance of Oxy-Fuel Gas equipment should conform to the provisions of the American National Standard Z49-1 "Safety in Welding and Cutting".
2. Ensure an appropriate gas shut-off valve is installed to the supply line prior to connection. This will make maintenance easier and can act as a safety valve in dangerous situations.
3. Attach the supply line to the reel inlet and tighten. The other end of incoming line can now be connected to desired supply source.
4. Attach reel hose outlet fitting to desired tool, or nozzle.
5. Purge air and check connections for leakage, also check hose reel for correct operation before use. (See Operation section.)

## OPERATION

### UNWINDING THE HOSE REEL

1. Holding the hose, carefully pull the hose out by hand.
2. Once reaching the desired hose length, slowly allow the hose to retract without releasing the hose from the hand hold.
3. When the reel reaches a latched position, the hose will slacken (indicating it has been locked in place) and it can then be fully released.



**CAUTION:**

**Do not direct a gas flame at the hose or hose reel.**

### WINDING THE HOSE REEL

1. Firmly pull the hose to release the latch.
2. Once the latch is released the length of the hose will tighten as the reel begins to retract the hose.
3. Walk the hose back to the reel whilst guiding the hose from left to right; allowing it to sit neatly into the reel housing.



**CAUTION:**

**Always hold and drive the hose while rewinding it, to avoid damage to the machine, surrounding objects or injuries to people.**

4. Check the hose condition daily for wear or damage and check the swivel fitting for leakage. Replace any worn, damaged, or leaking parts with original parts from Macnaught.



**CAUTION:**

**Should a gas "Flashback" occur, the swivel seals should be replaced. "Flashback check valves are also recommended to reduce the risk of backflow and "Flashback" a gas "Flashback" occur, replacement of the swivel seals is recommended. The use of "Flashback" check valves is recommended to reduce the risk of backflow and "Flashback".**

## MAINTENANCE



**IMPORTANT:**

**Any maintenance should be carried out by a suitably qualified person, carefully following the information provided in this manual.**



**IMPORTANT:**

**Replacement seal kits are fluid / gas specific. Only use seal kits that match the correct fluid / gas type.**



**CAUTION:**

**Always close the supply of fluid / gas to the reel and release the line pressure / vent the hose before carrying out any maintenance on the reel.**

## GENERAL MAINTENANCE

1. Always close the supply of fluid / gas to the reel and release the line pressure / vent the hose before carrying out any maintenance on it.
2. It is recommended that leak tests on all equipment be carried out at least once a month, or when replacing any supply equipment.
3. Replace the flexible hose as soon as it shows any sign of wear and tear, or deterioration, due to the different conditions of the environment. We advise you to replace it every 12 months.
4. Replace the seal inside the revolving joint in case of leaks due to wear and tear.
5. Any replacement of hose reel parts should be done using original spare parts (see the spare parts list).
6. We advise you to contact Macnought for any possible anomaly and before replacing any part.
7. After every maintenance operation, ensure you replace every protection that has been removed.

## INCREASING SPRING TENSION



**CAUTION:**

Always close the supply of fluid / gas to the reel and release the line pressure / vent the hose before carrying out any maintenance on the reel.

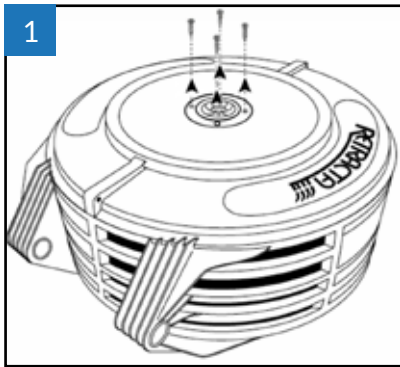

1. Remove screws.

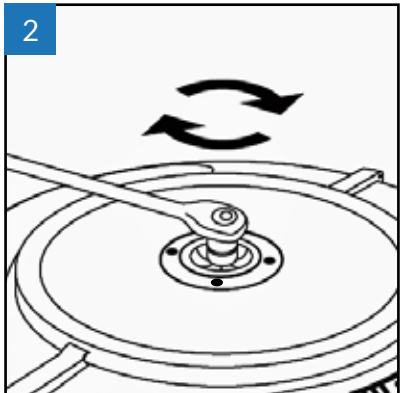

2. Add two complete turns. Note one click on the hub equals 90°.

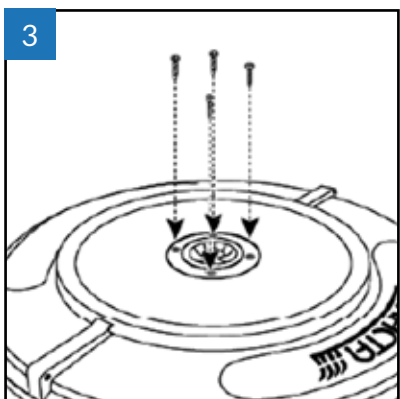

3. Replace screws.

**RACR ADJUSTMENT CONTROL INSTRUCTIONS  
(FOR MODELS FITTED WITH RACR)**

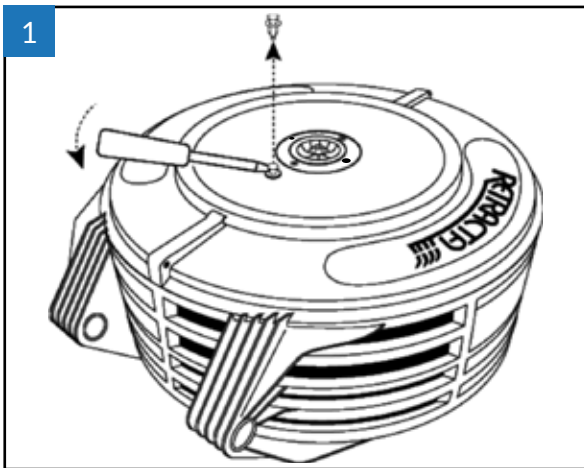
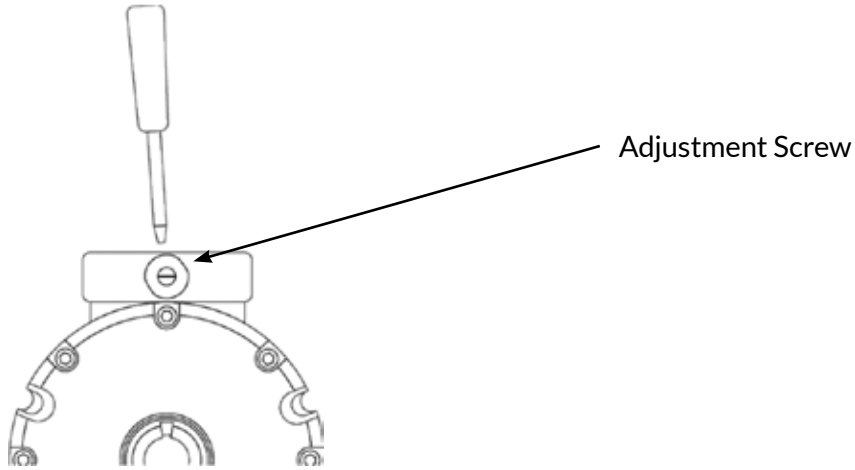

1. Lift centre button to unlock then lift out plug.

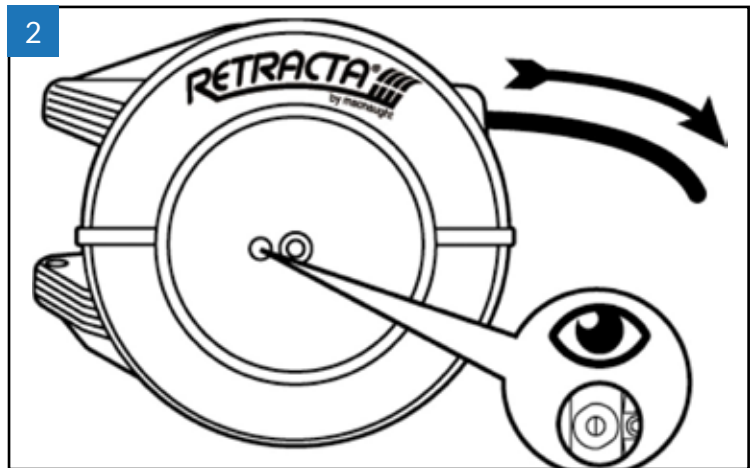

2. Pull hose out and latch when adjustment screw appears.

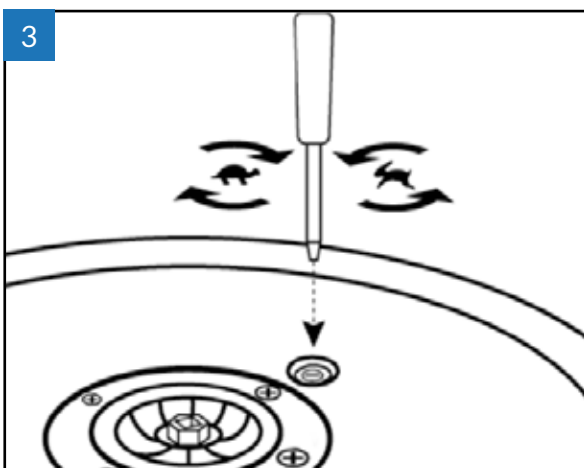

3. Adjust speed as desired  
(Clockwise for slower return)  
(Counter clockwise for faster return).

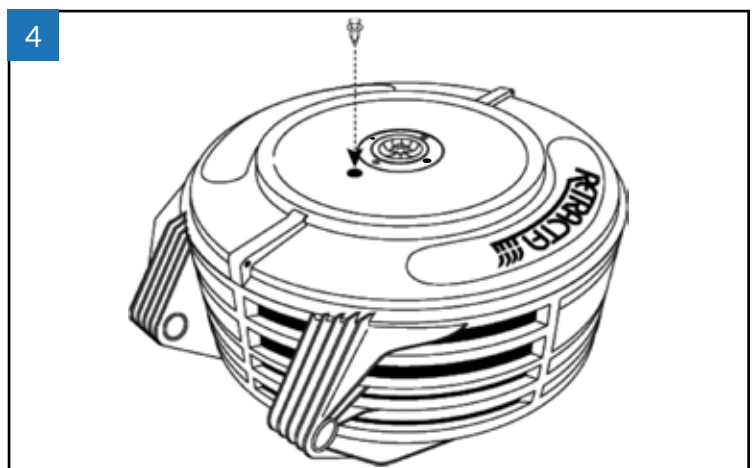

4. Replace plug then press centre button to lock.

## REMOVING & REPLACING TENSION SIDE PLATE



**CAUTION:**

Always close the supply of fluid / gas to the reel and release the line pressure / vent the hose before carrying out any maintenance on the reel.

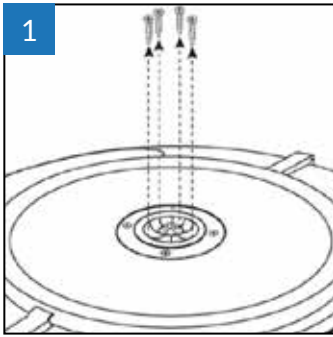

1. Remove screws with magnetic screwdriver.

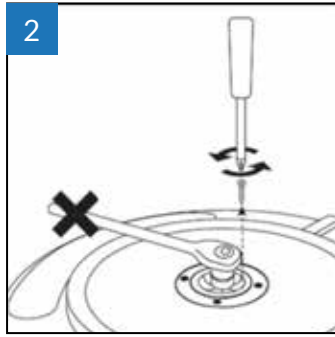

2. Hold hub and the four outside screws.

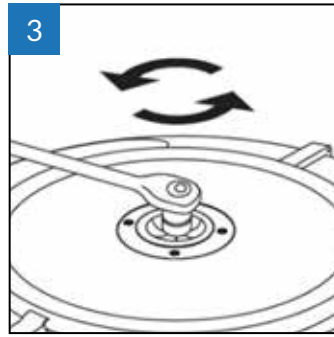

3. Release spring tension.

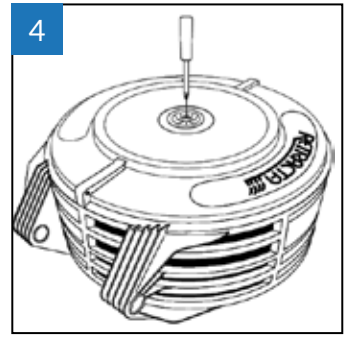

4. Remove screw and center hub.

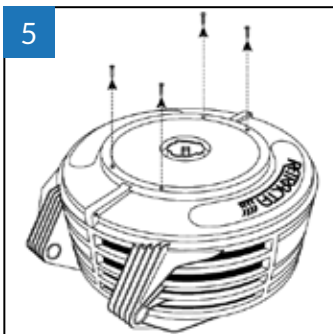

5. Remove screws.

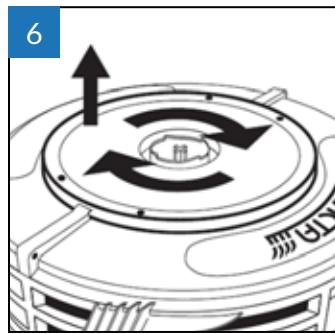

6. Remove side plate.

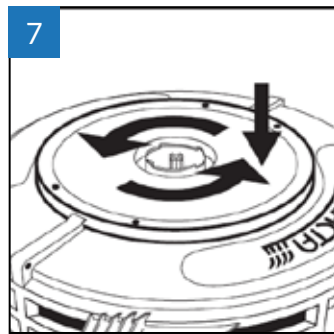

7. Fit new side plate.

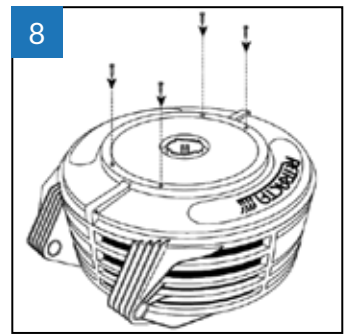

8. Fit screws.

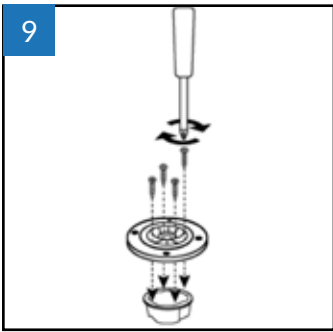

9. Fit screws.

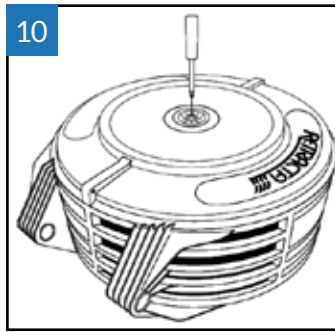

10. Fit screw.

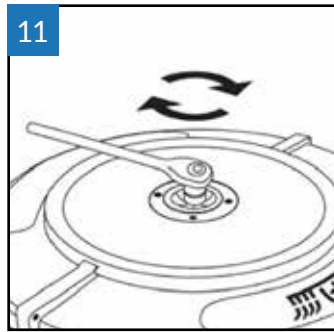

11. Add 2 complete turns.

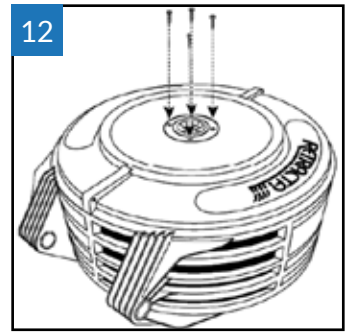

12. Fit screws.

## GAS LEAK TEST PROCEDURE



**CAUTION:**

**Always close the supply of gas to the reel and vent the hose before carrying out any maintenance on the reel.**

1. Test each hose line separately and ensure all connections are tight.
2. Always close the supply of gas to the reel and vent the line before carrying out any maintenance on it.
3. Close both nozzle valves.
4. Open the supply line cylinder valve for the line being tested and adjust the delivery pressure to the gas-specific recommended pressure.
5. Close the supply line cylinder valve and check the gauge to ensure there is no drop in pressure. If there is a drop in pressure, check all connections, then re-pressure and test all the connections including the hose by brushing it with a warm soapy water solution to look for the presence of any bubbles.
6. Open the test line nozzle valve and re-close to vent the gas test line. If the reel has a twin line gas hose, repeat steps 3, 4 and 5 with the second hose line, with the delivery pressure set to the gas-specific recommended pressure. Vent the second line.
7. Replace or repair any faulty parts immediately and repeat the Gas Leak Test Procedure.

**HOSE REPLACEMENT – FLUIDS (Excluding Grease)**  
(COMPRESSED AIR / WATER / OIL / WEEDICIDE / PESTICIDE / F.R.A.S.)



**CAUTION:**

Always close the supply of fluid to the reel and release the line pressure before carrying out any maintenance on the reel.

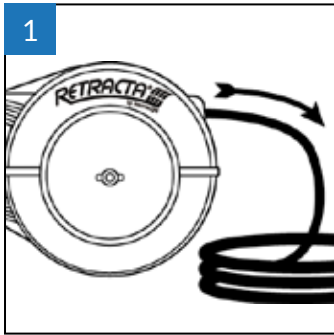

1. Pull out hose and latch.

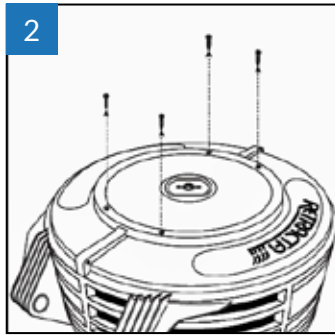

2. Remove screws.

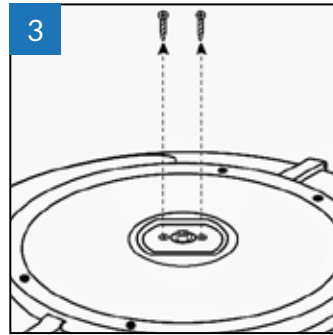

3. Remove screws.

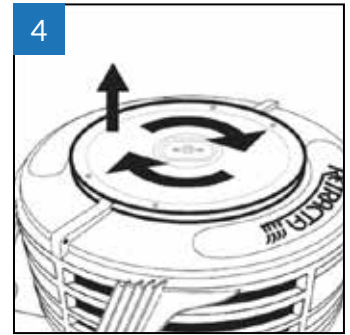

4. Remove plate.

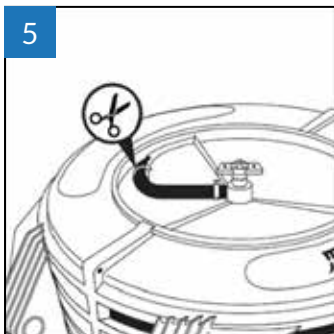

5. Remove cable tie.

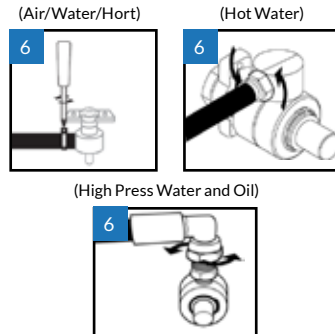

6. Remove swivel.

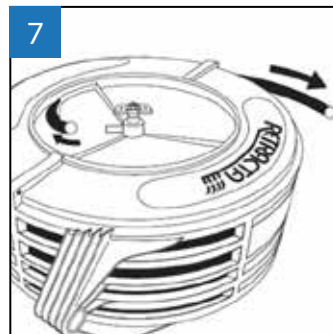

7. Remove old hose.

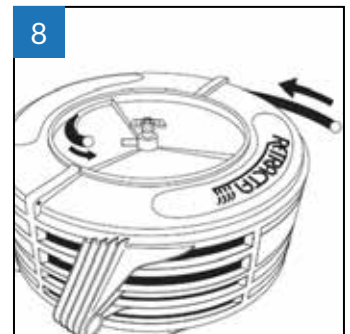

8. Fit new hose.

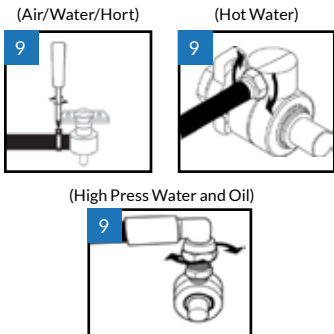

9. Attach hose to the swivel.

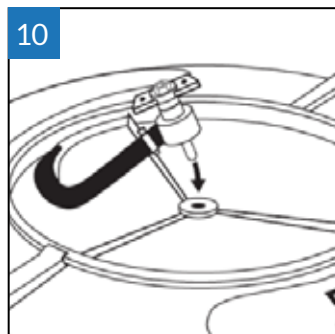

10. Fit swivel assembly.

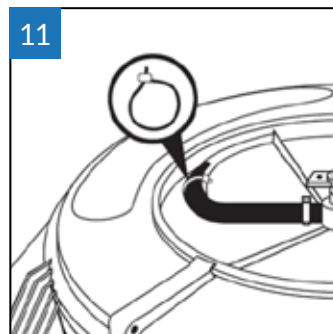

11. Fit cable tie.



12. Fit sideplate.

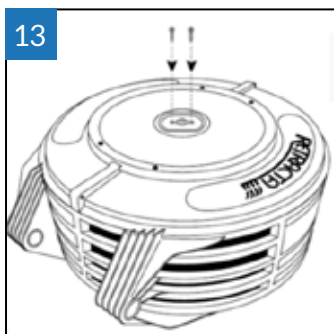

13. Fit screws.

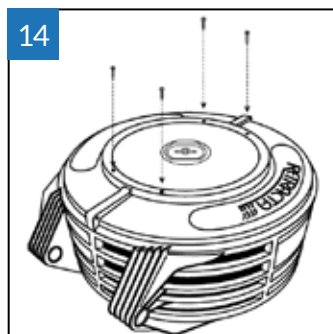

14. Fit screws.

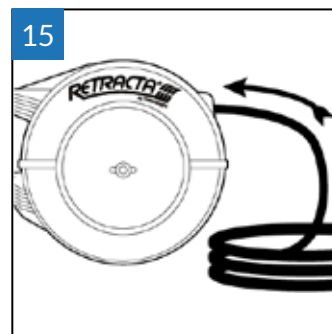

15. Recoil hose evenly into reel.

## HOSE REPLACEMENT - GREASE



**CAUTION:**

Always close the supply of fluid to the reel and release the line pressure before carrying out any maintenance on the reel.

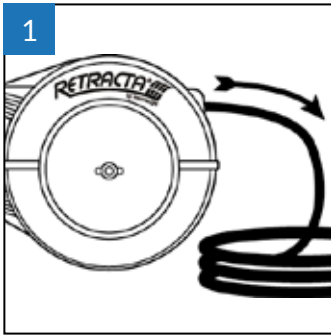

1. Pull out hose and latch.

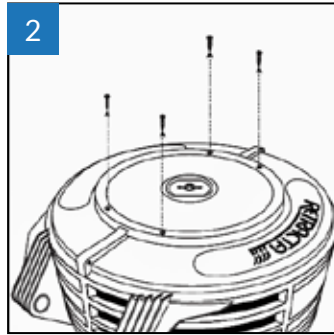

2. Remove screws.

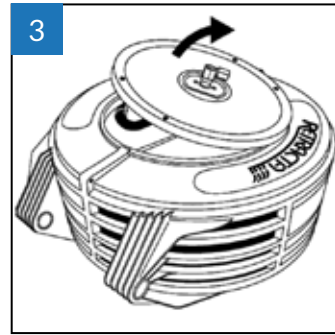

3. Remove side plate.

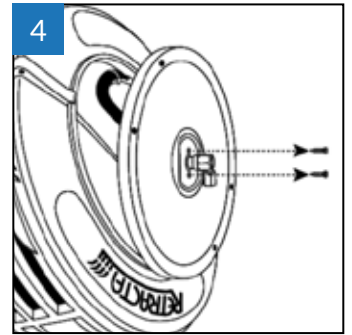

4. Remove screws.

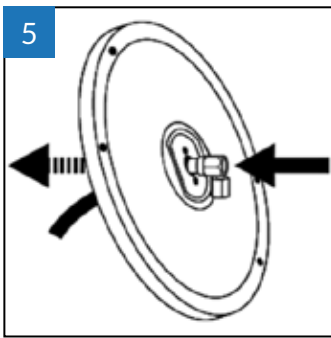

5. Remove swivel.

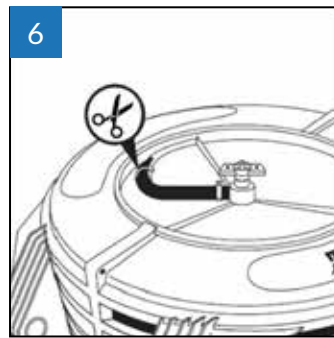

6. Remove cable tie.

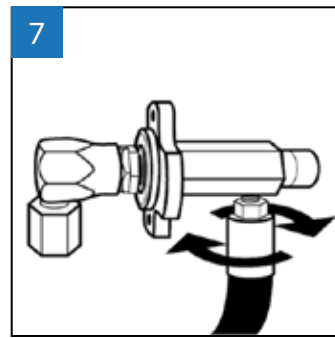

7. Remove hose from swivel.

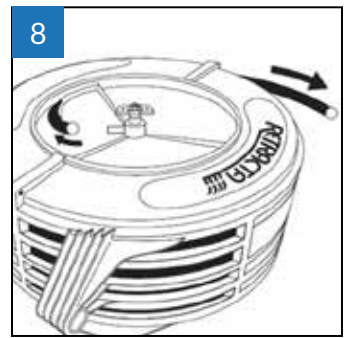

8. Remove old hose.

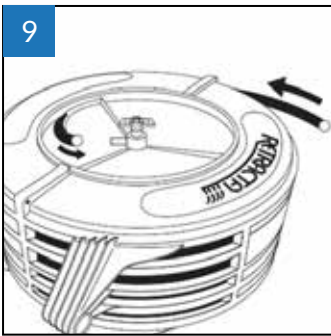

9. Fit new hose.

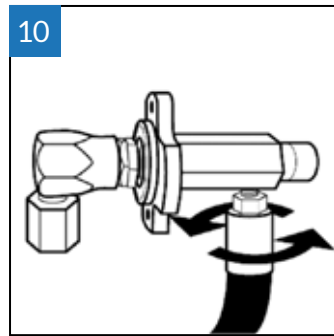

10. Fit swivel assembly.

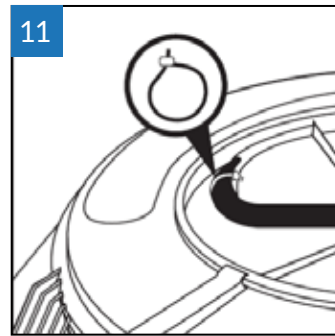

11. Fit cable tie.

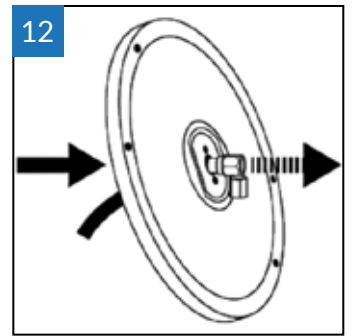

12. Fit swivel through side plate.

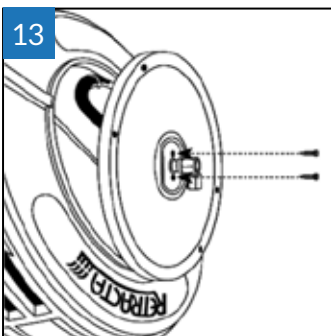

13. Fit screws.

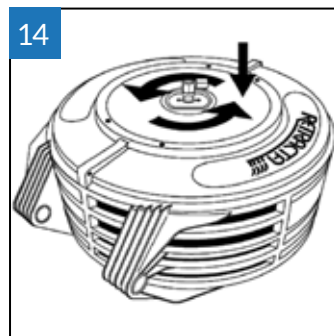

14. Fit side plate.

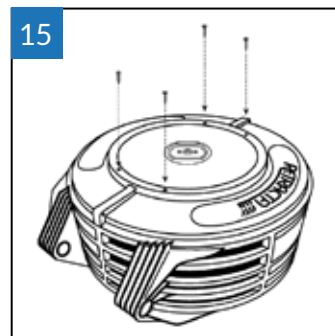

15. Fit screws.

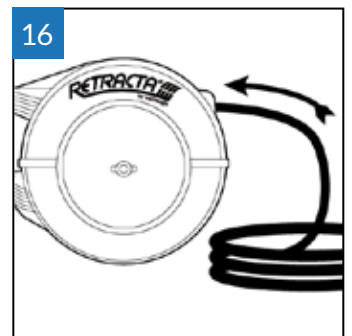

16. Recoil hose evenly into reel.

## HOSE REPLACEMENT – GAS (OXYACETYLENE / OXYGEN & LPG / ARGON / LPG)



### CAUTION:

Always close the supply of gas to the reel and vent the hose before carrying out any maintenance on the reel.



### IMPORTANT:

After replacing the hose, it is important that a leak test is performed. See Gas Leak Test Procedure section of this instruction manual.

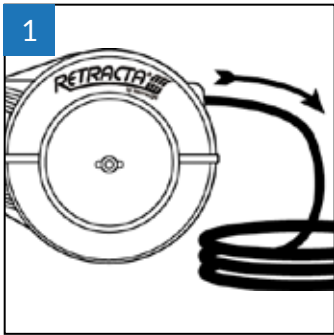

1. Pull out hose and latch.

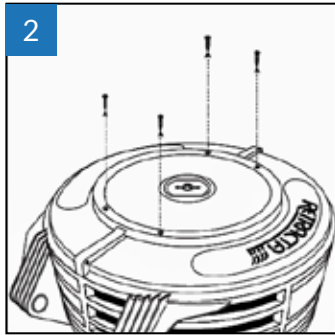

2. Remove screws.

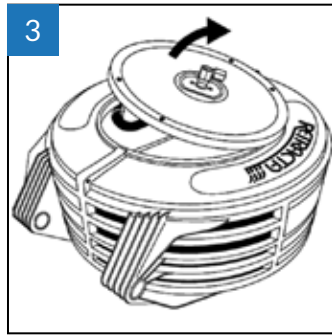

3. Remove sideplate.

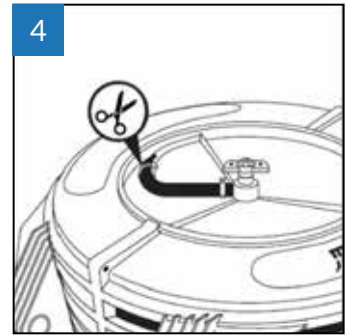

4. Remove cable tie.

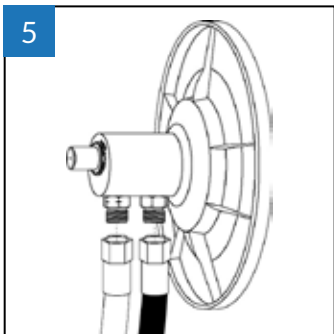

5. Remove hose from swivel.

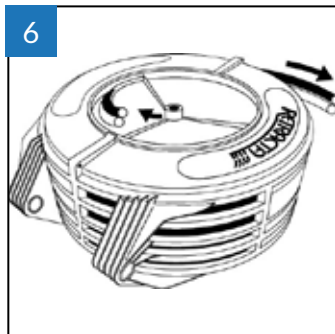

6. Remove old hose.

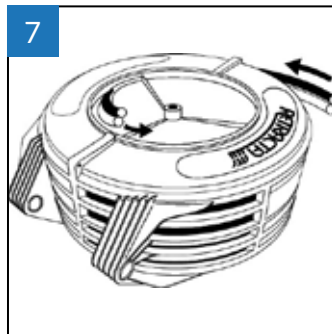

7. Fit new hose.

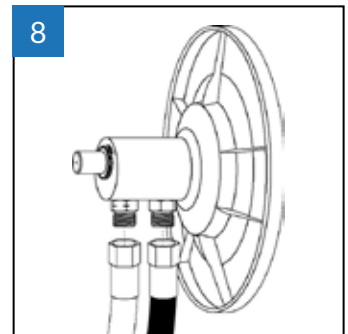

8. Fit hose to swivel.

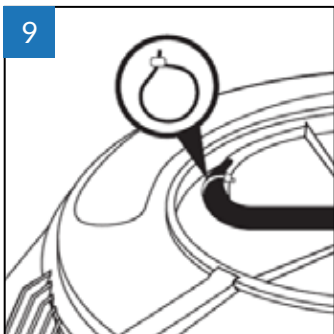

9. Fit cable tie.

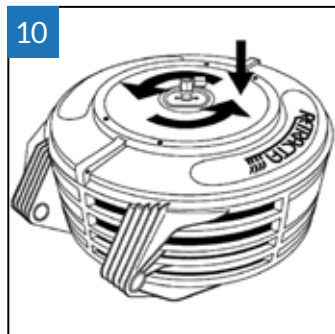

10. Fit side plate.

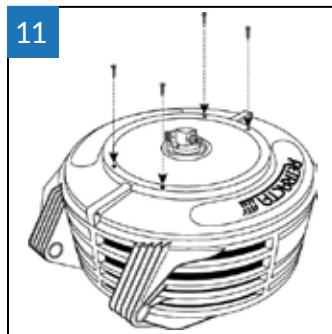

11. Fit screws.

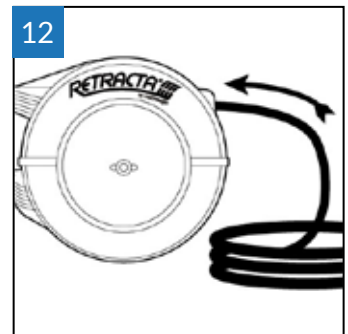

12. Recoil hose evenly into reel.

## SWIVEL & SWIVEL SEALS REPLACEMENT – FLUIDS

**(Excluding Hot Water Oil & Grease)**

(COMPRESSED AIR / WATER / WEEDICIDE / PESTICIDE / F.R.A.S.)



### CAUTION:

Always close the supply of fluid to the reel and release the line pressure before carrying out any maintenance on the reel.

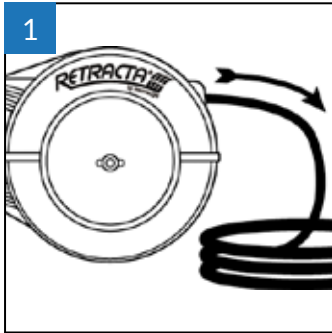

1. Pull out hose and latch.

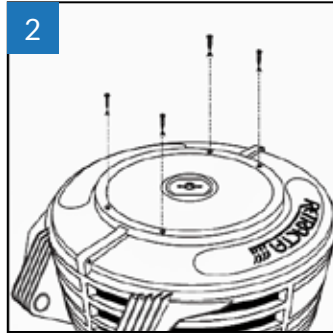

2. Remove screws.

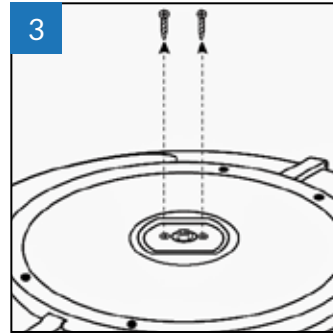

3. Remove screws.

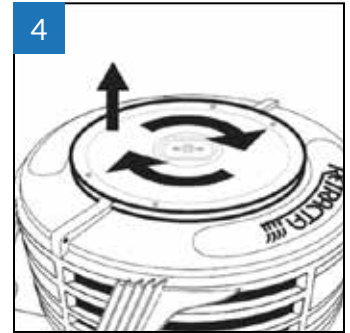

4. Remove plate.

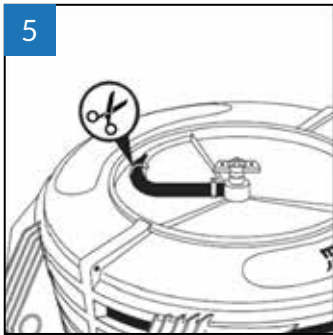

5. Remove cable tie.

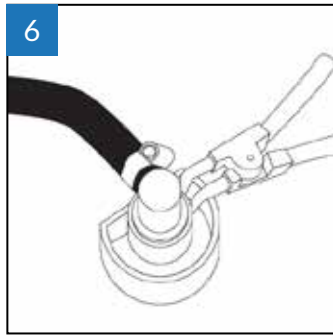

6. Remove circlip.

### Swivel O'ring Replacement instructions (use steps 1-7 & 9-14)

7. a) Remove body from shaft.
- b) Replace o'rings.
- c) Apply water resistant grease.
- d) Re-fit swivel body and circlip.

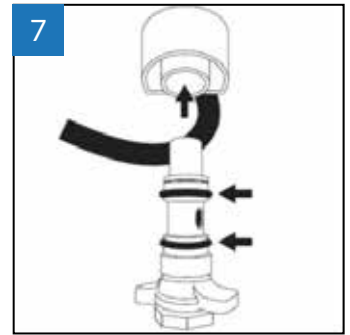

### Swivel replacement Instructions (use steps 1-5 & 8-14)

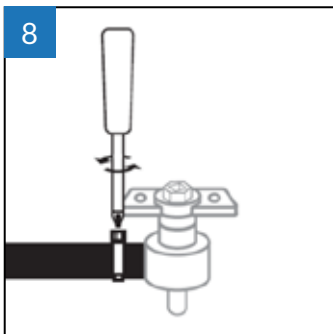

8. Remove swivel.

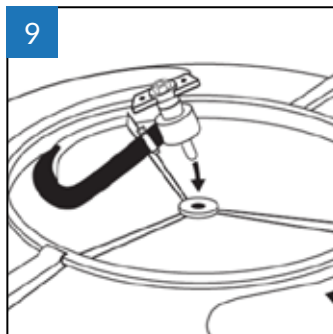

9. Fit swivel assembly.

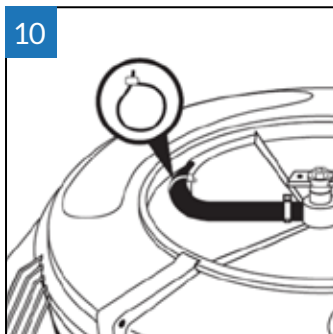

10. Fit cable tie.



11. Fit sideplate.

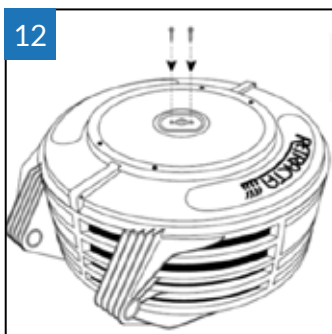

12. Fit screws.

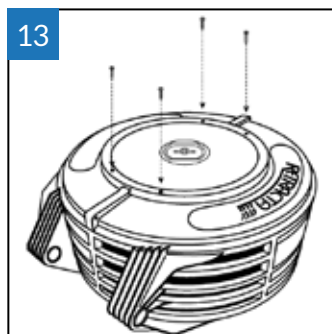

13. Fit screws.

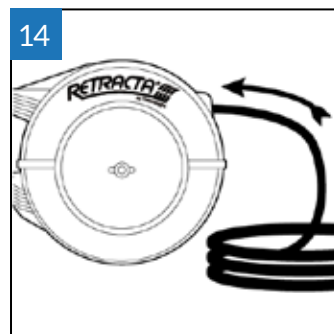

14. Recoil hose evenly into reel.

## SWIVEL & SWIVEL SEALS REPLACEMENT - FLUIDS (HOT WATER / OIL)



**CAUTION:**

Always close the supply of fluid to the reel and release the line pressure before carrying out any maintenance on the reel.

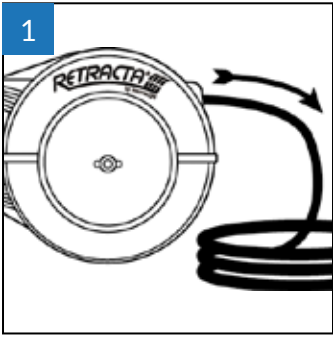

1. Pull out hose and latch.

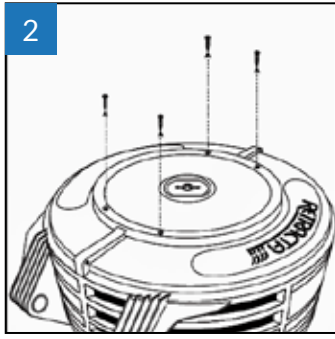

2. Remove screws.

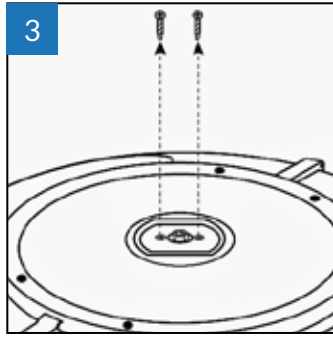

3. Remove screws.

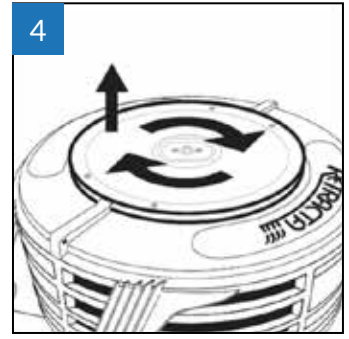

4. Remove plate.

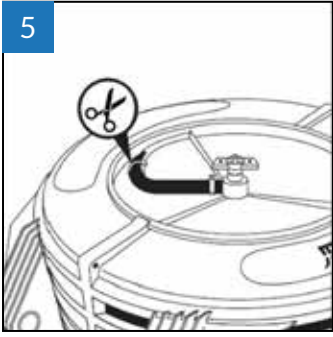

5. Remove cable tie.

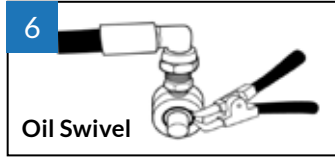

Oil Swivel

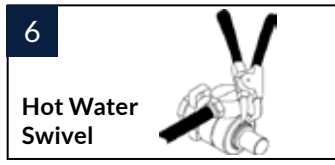

Hot Water Swivel

6. Remove circlip.

**Swivel O'ring Replacement instructions (use steps 1-7 & 10-15)**

7. a) Remove body from shaft.
- b) Replace o'rings.
- c) Apply water resistant grease.
- d) Re-fit swivel body and circlip.

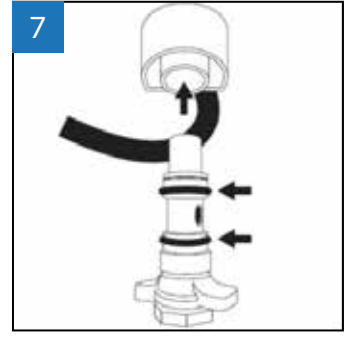

**Swivel replacement Instructions (use steps 1-5 & 8-15)**

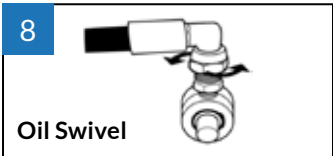

Oil Swivel

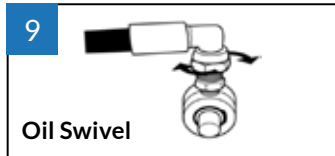

Oil Swivel

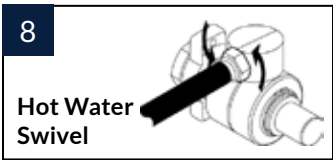

Hot Water Swivel

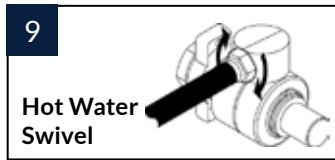

Hot Water Swivel

8. Remove hose from swivel.

9. Fit hose to new swivel.

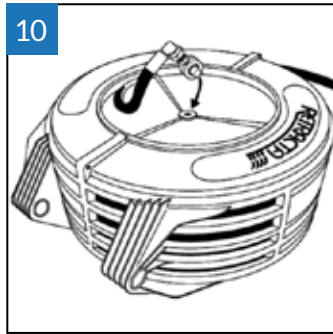

10. Fit swivel assembly.

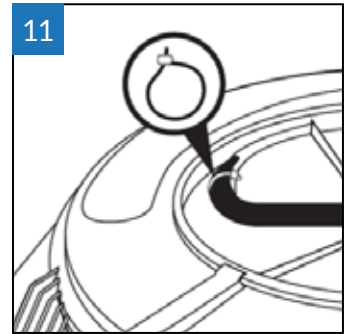

11. Fit cable tie.

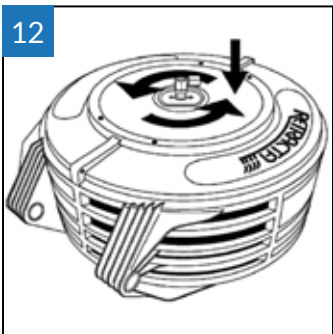

12. Fit sideplate.

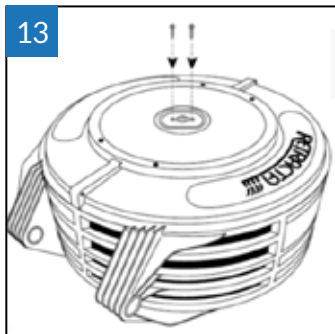

13. Fit screws.

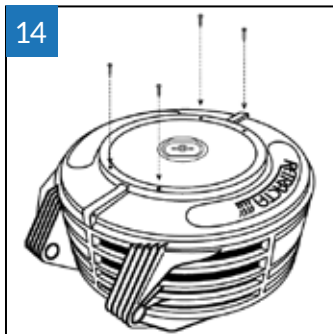

14. Fit screws.

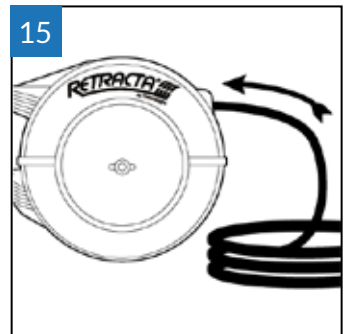

15. Recoil hose evenly into reel.

**SWIVEL REPLACEMENT – FLUIDS  
(GREASE)**



**CAUTION:**

**Always close the supply of fluid to the reel and release the line pressure before carrying out any maintenance on the reel.**

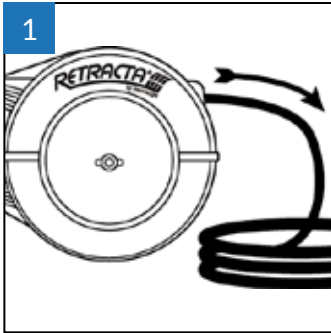

1. Pull out hose and latch.

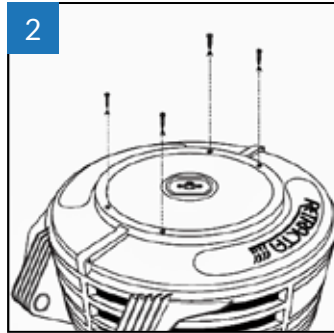

2. Remove screws.

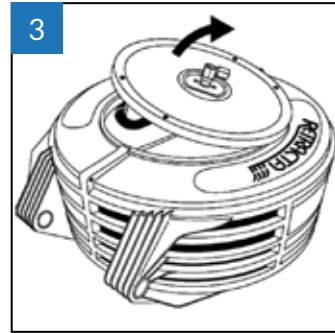

3. Remove sideplate.

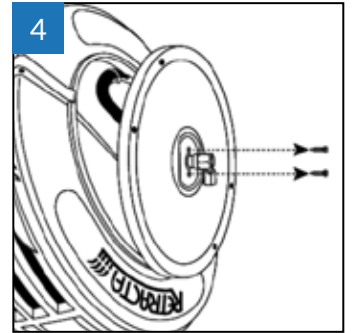

4. Remove screws.

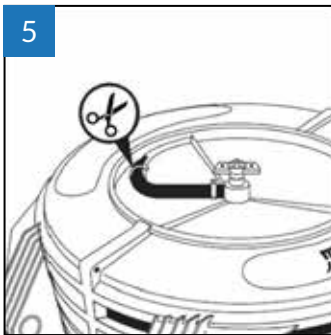

5. Remove swivel.

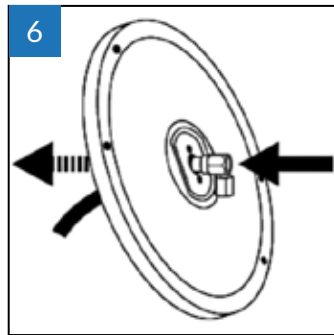

6. Remove cable tie.

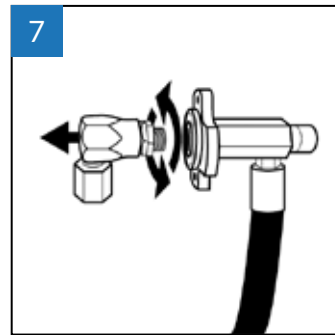

7. Remove SB6 swivel.

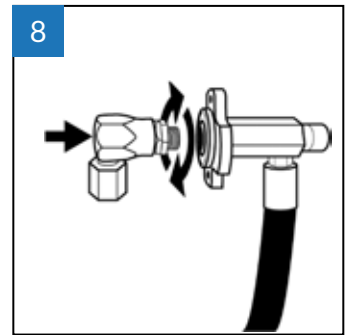

8. Fit new SB6 swivel.

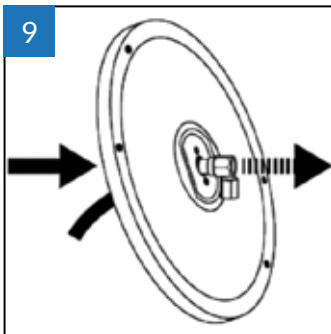

9. Fit swivel through side plate.

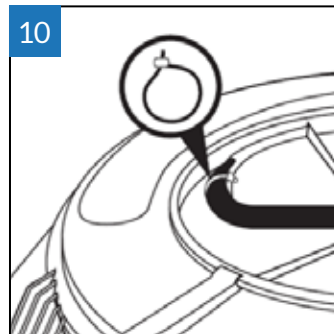

10. Fit cable tie.

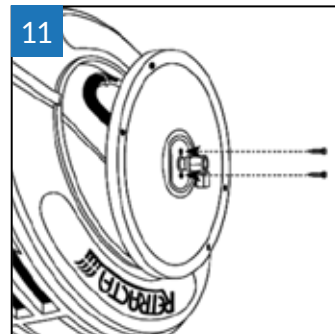

11. Fit screws.

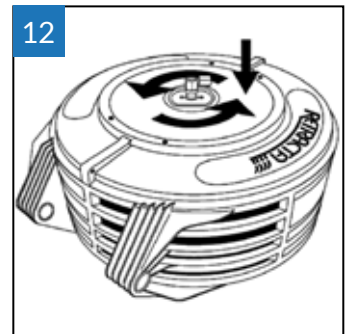

12. Fit sideplate.

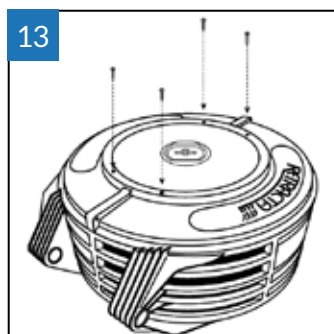

13. Fit screws.

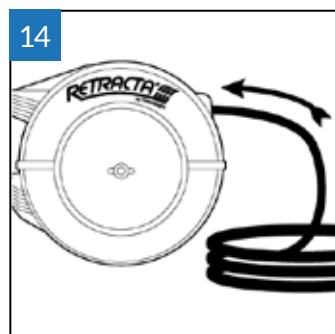

14. Recoil hose evenly into reel.

## SWIVEL SEAL REPLACEMENT – GAS (OXYACETYLENE / OXYGEN & LPG / ARGON / LPG)



### CAUTION:

Always close the supply of gas to the reel and vent the hose before carrying out any maintenance on the reel.



### CAUTION:

For O-ring seal lubrication use only 'HYPALUBE A514' or equivalent inert lubricant when required. Do not allow grease or oil to come into contact with the swivel or gas equipment.



### IMPORTANT:

After replacing the Swivel, it is important that a leak test is performed. See Gas Leak Test Procedure section of this instruction manual.

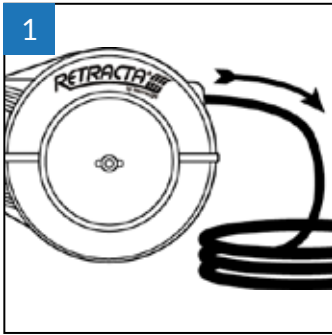

1. Pull out hose and latch.

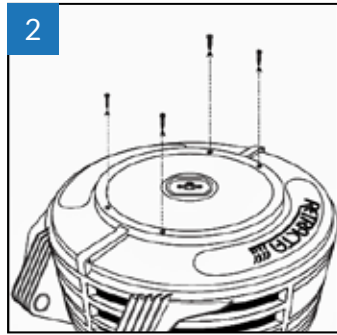

2. Remove screws.

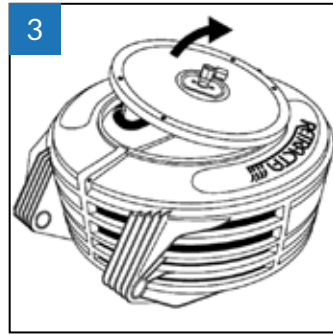

3. Remove sideplate.

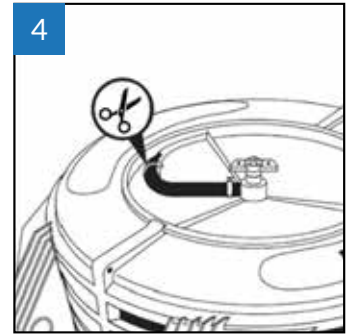

4. Remove cable tie.

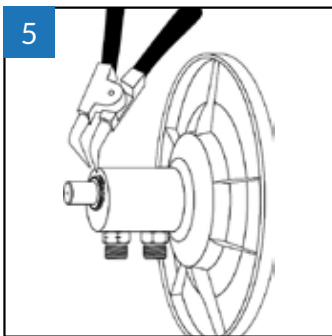

5. Remove circlip.

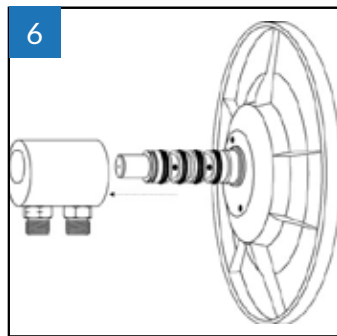

6. Remove swivel body.

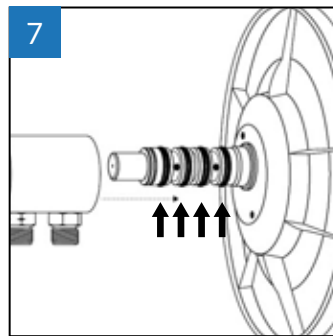

7. a) Apply grease to o'rings (only use 'HYPALUBE A514' or equivalent grease).  
b) Fit swivel body.

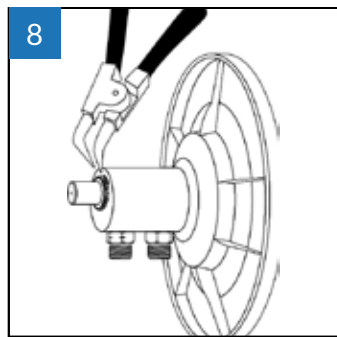

8. Fit circlip.

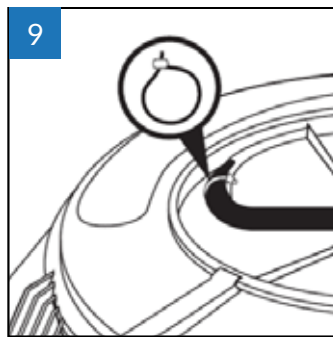

9. Fit cable tie.

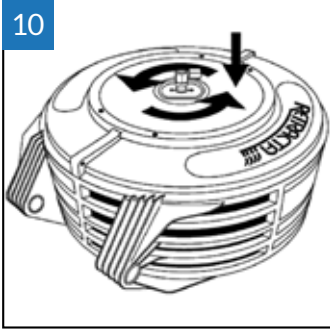

10. Fit side plate

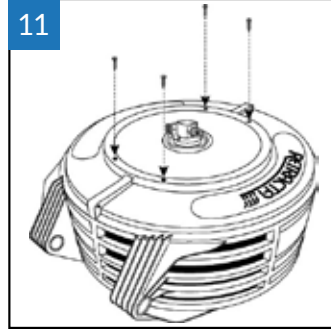

11. Fit screws.

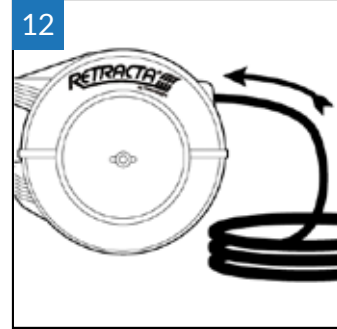

12. Recoil hose evenly into reel. Fit screws.

**SWIVEL REPLACEMENT – GAS**  
(OXYACETYLENE / OXYGEN & LPG / ARGON / LPG)



**CAUTION:**

Always close the supply of gas to the reel and vent the hose before carrying out any maintenance on the reel.



**CAUTION:**

For O-ring seal lubrication use only 'HYPALUBE A514' or equivalent inert lubricant when required. Do not allow grease or oil to come into contact with the swivel or gas equipment.



**IMPORTANT:**

After replacing the Swivel, it is important that a leak test is performed. See Gas Leak Test Procedure section of this instruction manual.

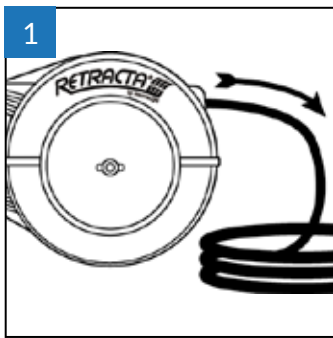

1. Pull out hose and latch.

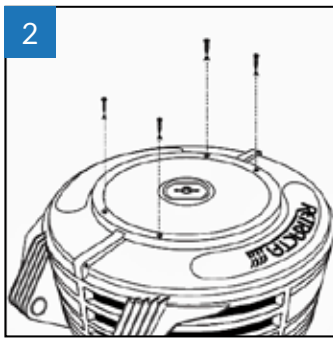

2. Remove screws.

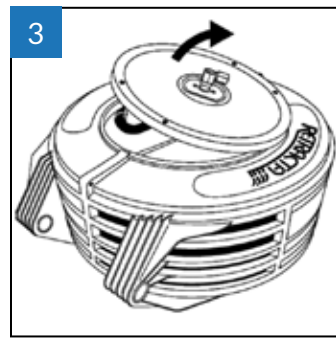

3. Remove sideplate.

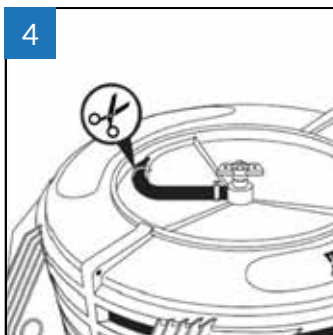

4. Remove cable tie.

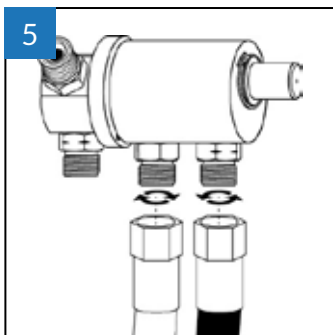

5. Remove hose.

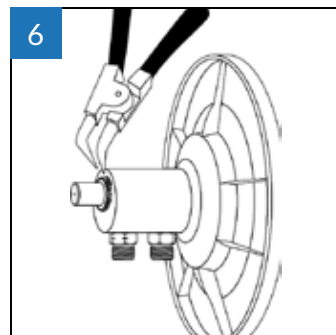

6. Remove circlip.

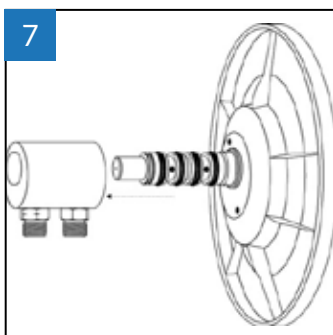

7. Remove swivel body.

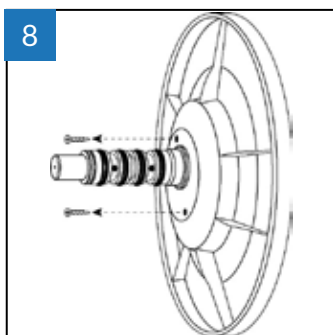

8. Remove screws.

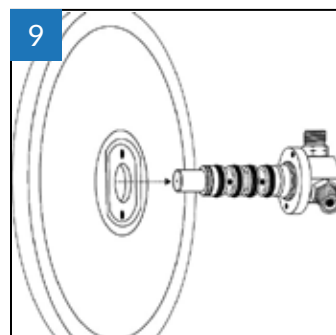

9. Remove swivel shaft.

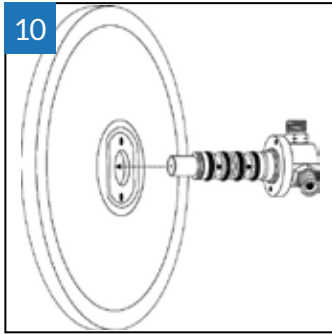

10. Fit new shaft.

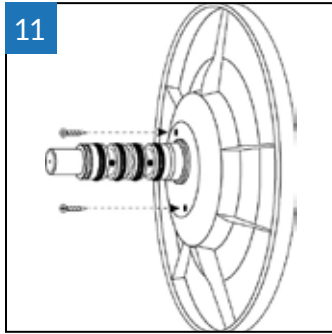

11. Fit screws.

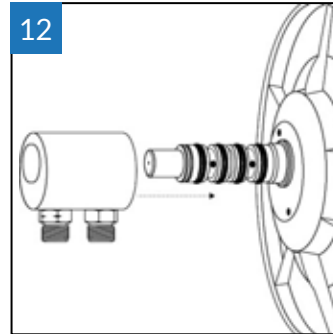

12. a) Apply grease to o'rings  
(only use 'HYPALUBE A514'  
or equivalent grease).  
b) Fit swivel body.

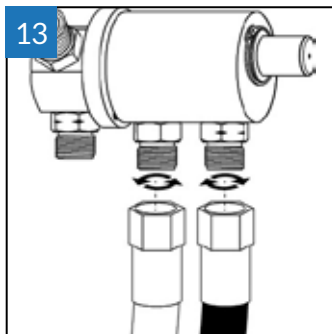

13. Fit Hose.

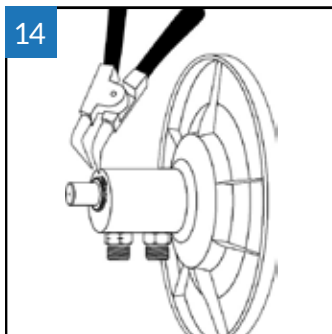

14. Fit circlip.

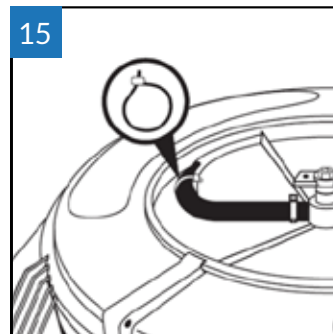

15. Fit cable tie.

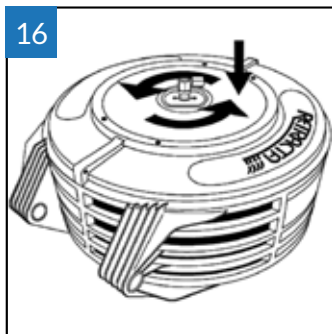

16. Fit side plate.

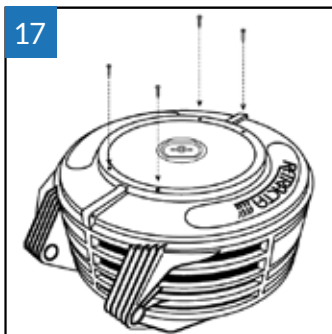

17. Fit screws.

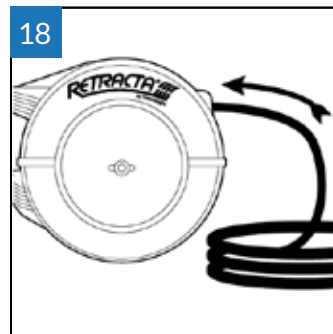

18. Recoil hose evenly into reel.

## EXPLODED PARTS DIAGRAMS

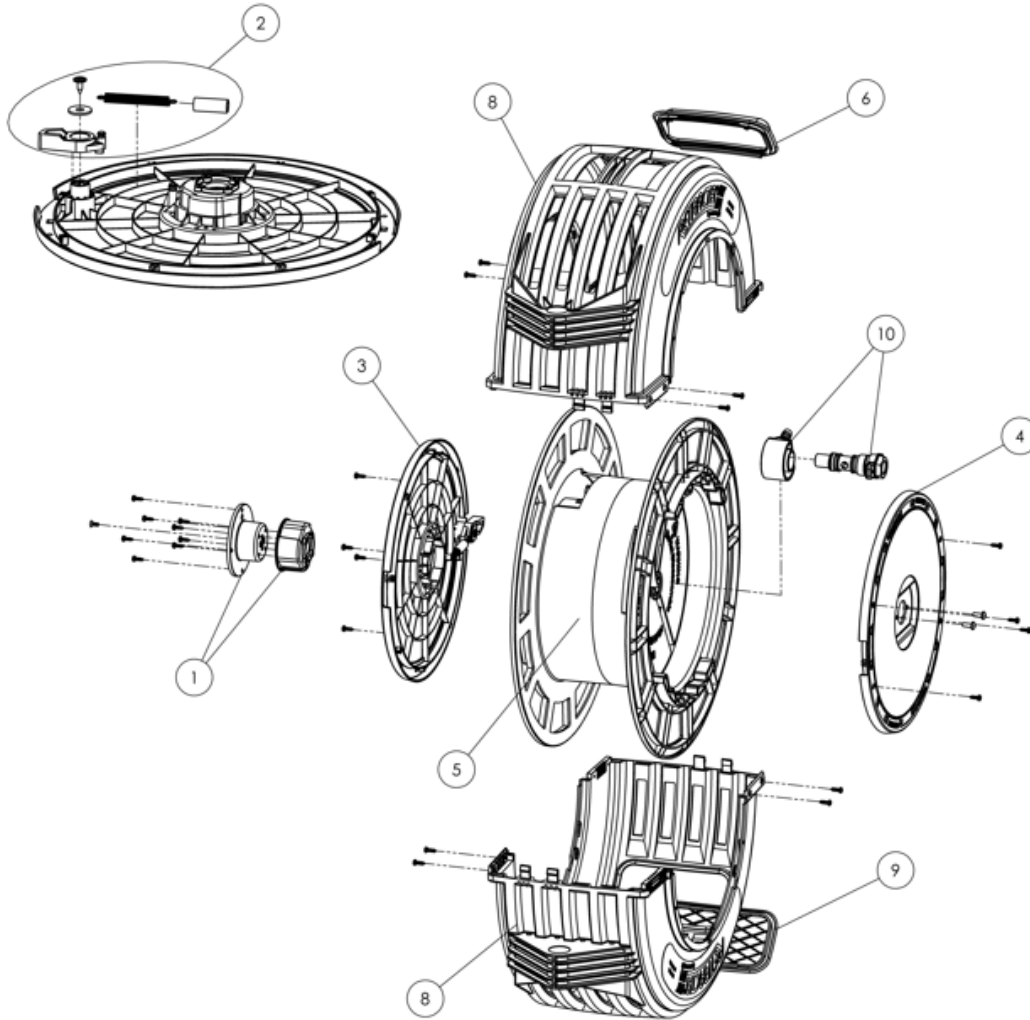

Note:

1. Outer casing set is supplied with screws, mouth set and lower insert
2. Standard bracket not shown

## GENERIC SPARE PARTS

Item no	Description	Spare part no
1	Tension Hub Set	R3THS
2	Latch Set	Included in item 3
3	Latching Side Plate	R3LPS
4	Inlet Side Plate	R3IPS
5	Drum Assembly	R3DAS
6	Mouth Set	R3MS
7	Standard Bracket (incl locking plate)	R3SBS
8	Outer Casing Set (nominate color)	R3OC-* (replace * with colour)
9	Lower Insert (nominate colour)	R3LIS-* (replace * with colour)
10	Swivel	Fluid / Gas Specific

**HOSE & HOSE STOPPER SPARE**

Hose Outlet Thread	Hose Type	Hose ID	Length	Hose Part No.	Hose Stopper Part No.	
BSPT	Air / Water (AR)	10mm (3/8")	20m	RH35S	RP156-1S	
		12mm (1/2")	15m	RH22S	RP156-2S	
	Air / Water (AW)	12mm (1/2")	20m	RH150S	RP156-2S	
		10mm (3/8")	15m	RH151S	RP156-1S	
		10mm (3/8")	20m	RH152S	RP156-1S	
		10mm (3/8")	25m	RH215S	RP156-1S	
		12mm (1/2")	15m	RH153S	RP156-2S	
		12mm (1/2")	20m	RH154S	RP156-2S	
		12mm (1/2")	25m	RH216S	RP156-2S	
	Air / Water (FLEX Yellow)	10mm (3/8")	20m	RH171S	RP156-5S	
		12mm (1/2")	20m	RH175S	RP156-1S	
	Air / Water (FLEX Orange)	10mm (3/8")	20m	RH181S	RP156-5S	
		12mm (1/2")	20m	RH185S	RP156-1S	
	Cold Water	12mm (1/2")	15m	RH40S	RP156-3S	
		12mm (1/2")	20m	RH155S	RP156-2S	
	Hot Water	12mm (1/2")	15m	RH41S	RP156-2S	
		12mm (1/2")	20m	RH168S	RP156-2S	
	Garden / Horticulture	12mm (1/2")	18m	RH191S	RP156-1S	
		12mm (1/2")	25m	RH203S	RP156-1S	
	High Pressure Water	10mm (3/8")	20m	RH159S	RP156-1S	
	Fire Resistant Anti-static (FRAS)	12mm (1/2")	15m	RH202S	RP156-3S	
	Weed Pesticide	12mm (1/2")	16m	RH50S	RP156-2S	
	Grease	5mm (1/4")	10m	RH45S	RP156-5S	
		5mm (1/4")	15m	RH156S	RP156-5S	
	Oil	10mm (3/8")	10m	RH84S	RP156-1S	
		12mm (1/2")	15m	RH161S	RP156-3S	
	Feed Hose (BSP Models) No outlet fitting	Garden / Horticulture	12mm (1/2")	2m	RH192S	N/A
	NPT	Air / Water (AW)	10mm (3/8")	65ft	RH211S	RP156-5S
12mm (1/2")			65ft	RH212S	RP156-1S	
Air / Water (FLEX Yellow)		10mm (3/8")	65ft	RH169S	RP156-5S	
		12mm (1/2")	65ft	RH173S	RP156-1S	
Air / Water (FLEX Orange)		10mm (3/8")	65ft	RH179S	RP156-5S	
		12mm (1/2")	65ft	RH183S	RP156-1S	
Hot Water		12mm (1/2")	65ft	RH196S	RP156-2S	
Grease		5mm (1/4")	50ft	RH197S	RP156-5S	
Oil	12mm (1/2")	50ft	RH193S	RP156-3S		
Garden / Horticulture	12mm (1/2")	60ft	RH189S	RP156-1S		
Feed Hose (NPT Models) 3/4"-11 / 2 GHT (F)	Garden / Horticulture	12mm (1/2")	6ft	RH190S	N/A	
Gas Thread UNF	Oxyacetylene	5mm (1/4")	15m	RH30S	RP156-4S	
	Oxygen / LPG (Propane)	5mm (1/4")	15m	RH60S	RP156-4S	
	LPG (Propane)	5mm (1/4")	15m	RH201S	RP156-6S	
	Argon	5mm (1/4")	15m	RH200S	RP156-6S	

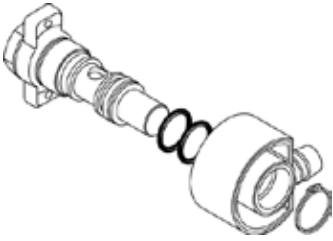
**SWIVEL & SEAL KIT SPARE PARTS**
**Air / Air-Water / Coolant**

Fluid / Gas	Swivel Part No.	Seal Kit Part No.
Air / Water - 3/8" BSPT (10mm)	RS116AS	BS115VS
Air / Water - 1/2" BSPT (12mm)	RS115AS	BS115VS
Air / Water - 3/8" NPT (10mm)	RS130AS	BS115VS
Air / Water - 1/2" NPT (12mm)	RS129AS	BS115VS
Coolant	RS117AS	BS115VS

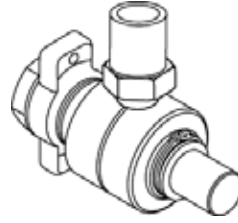
**High Pressure Hot Water**

Fluid / Gas	Swivel Part No.	Seal Kit Part No.
High Pressure	RS85S	Complete Swivel Required

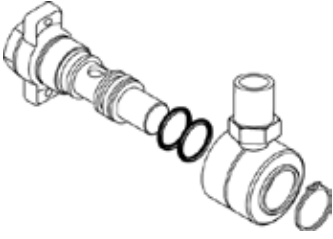
**Oil**

Fluid / Gas	Swivel Part No.	Seal Kit Part No.
Oil - 3/8" (10mm)	RS117AS	BS115VS
Oil - 1/2" (12mm)	RS117AS	BS115VS

O'Ring seal kit  
BS115Vs

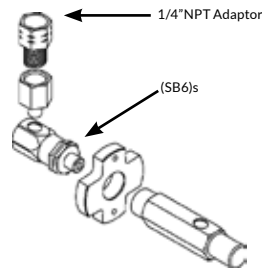
**Grease**

Fluid / Gas	Swivel Part No.	Seal Kit Part No.
Grease	RS124AS	Complete Swivel Required

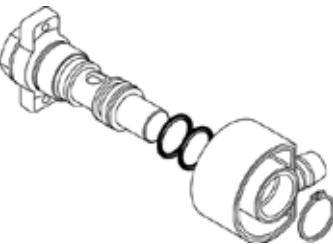
**Cold Water**

Fluid / Gas	Swivel Part No.	Seal Kit Part No.
Cold Water	RS118AS	BS115-1K

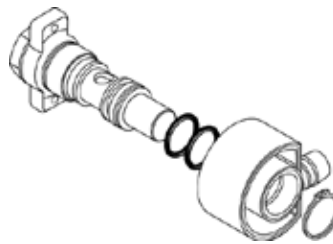
**Weedicide / Pesticide**

Fluid / Gas	Swivel Part No.	Seal Kit Part No.
Weedicide / Pesticide	RS67S	BS115VS

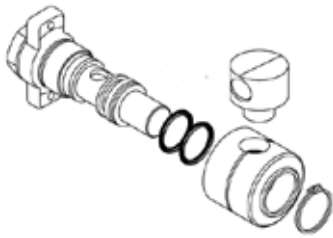
**Hot Water**

Fluid / Gas	Swivel Part No.	Seal Kit Part No.
Hot Water	RS119AS	BS115ES

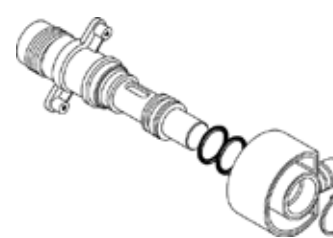
**Garden / Horticulture**

Fluid / Gas	Swivel Part No.	Seal Kit Part No.
Garden / Horticulture	RS1S	BS115-1K

SAFETY

 TECHNICAL  
DETAILS

INSTALLATION

OPERATIONS

MAINTENANCE

TROUBLESHOOTING

COMPLIANCE

 LIMITED  
WARRANTY

SAFETY

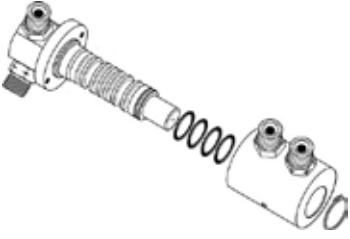
**Oxyacetylene**

Fluid / Gas	Swivel Part No.	Seal Kit Part No.
Oxyacetylene	RS123AS	OA-1K

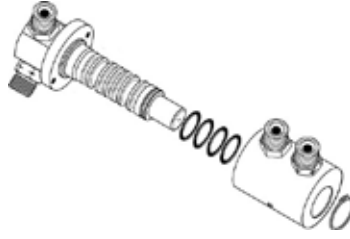
**Oxygen / LPG (Propane)**

Fluid / Gas	Swivel Part No.	Seal Kit Part No.
Oxygen / LPG (Propane)	RS123BS	OLPG-1K

 TECHNICAL  
DETAILS

INSTALLATION

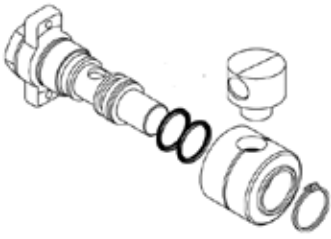
**Argon**

Fluid / Gas	Swivel Part No.	Seal Kit Part No.
Argon	RS140AS	OA-1K

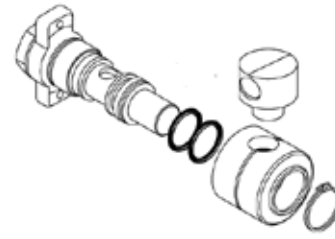
**LPG (Propane)**

Fluid / Gas	Swivel Part No.	Seal Kit Part No.
LPG (Propane)	RS139AS	OLPG-1K

OPERATIONS

**ACCESSORY SPARE PARTS**

Bracket - Wall Mount	BU200
Bracket - Bench Mount	BB200
Cold Wash Nozzle Set	RH51S
Coolant Gun (Coolant reel only)	R3CG
Garden / Horticulture Nozzle Set	DR-GSETS



MAINTENANCE

TROUBLESHOOTING

COMPLIANCE

 LIMITED  
WARRANTY

## TROUBLESHOOTING GUIDE

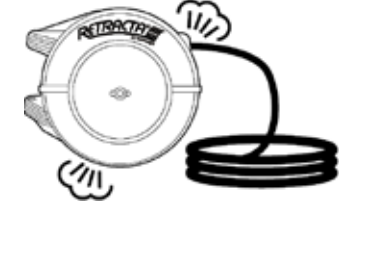
<p><b>Hose does not retract correctly</b></p> 	<p>A) Outlet nozzle, gun or tool is too heavy.</p> <p>B) Spring is fatigued and lost tension.</p>	<p>Refer to <b>INCREASE SPRING TENSION</b> on page 11.</p>
<p><b>Reel does not latch</b></p> 	<p>A) Incorrect operation.</p> <p>B) Latch assembly is broken.</p>	<p>Refer to <b>REMOVE/ REPLACE TENSION SIDE PLATE</b> on page 13.</p>
<p><b>Reel does not latch</b></p> 	<p>Split in hose.</p>	<p>Refer to <b>HOSE REPLACEMENT</b> on pages 15.</p>
<p><b>Reel does not latch</b></p> 	<p>Swivel or swivel seals are worn.</p>	<p>Refer to <b>SWIVEL OR SWIVEL SEAL REPLACEMENT</b> on pages 5 or 6.</p>

# COMPLIANCE DECLARATION OF CONFORMITY

SAFETY

TECHNICAL  
DETAILS

INSTALLATION

OPERATIONS

MAINTENANCE

TROUBLESHOOTING

COMPLIANCE

LIMITED  
WARRANTY

EN (English)		Declaration of Conformity	
We:	Macnaught Pty Ltd	Of:	41-49 Henderson Street, Turrella NSW 2205, Australia
Declare that:	Retracta Hose Reel models prefixed AR, ARC, ARG, ARG, AW, CL, CLC, CW, CWC, DR, DRC, FRAS, GR, GRC, HP, HPC, HW, HWC, LPG, LPGC, OA, OAC, OG, OGC, OMP, OMPC, RO, ROC, RY, RYC, WD & WDC		
In accordance with:	2006/42/EC 2009/127/EC	(The Machinery Directive) (amending Directive - WD, DR & DRC models only)	
has been designed and manufactured to the following specifications:	EN ISO 12100: 2010 (Safety of Machinery)		
I hereby declare that the equipment named above has been designed to comply with the relevant sections of the above referenced specification. The product complies with all essential requirements of the Directives.			
Signed By:			
	Marco Uccellani, Engineering Manager, Macnaught Pty Ltd.		
Done at:	Macnaught Pty Ltd, 41-49 Henderson Street, Turrella, NSW 2205, Australia.		
Date:	26/08/2021		
			

FR (French)		Déclaration de conformité	
Nous,	Macnaught Pty Ltd,	41-49 Henderson Street, Turrella NSW 2205, Australie	
Déclarons que	Les modèles d'enrouleurs de tuyaux retracta aux préfixes AR, ARC, ARG, ARG, AW, CL, CLC, CW, CWC, DR, DRC, FRAS, GR, GRC, HP, HPC, HW, HWC, LPG, LPGC, OA, OAC, OG, OGC, OMP, OMPC, RO, ROC, RY, RYC, WD et WDC		
en vertu de :	2006/42/CE 2009/127/CE	(directive Machines) (directive modificative - modèles WD, DR et DRC uniquement)	
sont conçus et fabriqués selon la spécification suivante :	EN ISO12100: 2010 (sécurité Machines)		
Je déclare par la présente que les équipements mentionnés ci-dessus sont conformes aux sections appropriées de la spécification susmentionnée. Le produit est conforme à toutes les exigences principales des directives.			
Signé par :			
	Marco Uccellani, responsable de l'ingénierie, Macnaught Pty Ltd.		
Fait à :	Macnaught Pty Ltd, 41-49 Henderson Street, Turrella, NSW 2205, Australie		
Date :	26/08/2021		
			

DE (German)		Konformitätserklärungen	
Wir,	Macnaught Pty Ltd	mit Sitz in:	41-49 Henderson Street, Turrella NSW 2205, Australien
erklären, dass	die Retracta Schlauchtrommelmodelle mit den Präfixen AR, ARC, ARG, ARG, AW, CL, CLC, CW, CWC, DR, DRC, FRAS, GR, GRC, HP, HPC, HW, HWC, LPG, LPGC, OA, OAC, OG, OGC, OMP, OMPC, RO, ROC, RY, RYC, WD und WDC		
In Übereinstimmung mit den Verordnungen:	2006/42/EG 2009/127/EG	(Maschinenrichtlinie) (Änderungsrichtlinie, nur Modelle WD, DR und DRC)	
gemäß folgenden Spezifikationen konzipiert und hergestellt worden sind:	EN ISO12100: 2010 (Maschinensicherheit)		
Ich erkläre hiermit, dass die oben genannten Geräte so konzipiert wurden, dass sie mit den einschlägigen Abschnitten der oben genannten Spezifikation übereinstimmen. Das Produkt erfüllt alle grundlegenden Anforderungen der Richtlinien.			
Unterzeichnet von:			
	Marco Uccellani, Manager Ingenieurwesen, Macnaught Pty Ltd.		
Unternehmen, Ort:	Macnaught Pty Ltd, 41-49 Henderson Street, Turrella, NSW 2205, Australien.		
Datum:	26/08/2021		
			

ES (Spanish)		Declaraciones de	
Nosotros,	Macnaught Pty Ltd	De	41-49 Henderson Street, Turrella NSW 2205, Australia
Declaramos:	Modelos Retracta Hose Reel con prefijo AR, ARC, ARG, ARG, AW, CL, CLC, CW, CWC, DR, DRC, FRAS, GR, GRC, HP, HPC, HW, HWC, LPG, LPGC, OA, OAC, OG, OGC, OMP, OMPC, RO, ROC, RY, RYC, WD & WDC		
en conformidad con:	2006/42/EC 2009/127/EC	(La Directiva sobre maquinaria) (Directiva modificativa: solo los modelos WD, DR y DRC)	
ha sido diseñada y fabricada de acuerdo con las siguientes especificaciones:	EN ISO 12100: 2010 (Seguridad de la maquinaria)		
Por la presente declaro que el equipo mencionado anteriormente ha sido diseñado para cumplir con las secciones pertinentes de las especificaciones mencionadas con anterioridad. El producto cumple con todos los requisitos esenciales de las Directivas.			
Firmado por:			
	Marco Uccellani, Responsable de Ingeniería, Macnaught Pty Ltd.		
Redactado en:	Macnaught Pty Ltd, 41-49 Henderson Street, Turrella, NSW 2205, Australia.		
Fecha:	26/08/2021		
			

JA (Japanese)		適合宣言書	
当社	Macnaught Pty Ltd	所在地:	41-49 Henderson Street, Turrella NSW 2205, Australia
は、次の製品が以下の指令及び仕様に準拠して設計、製造されていることを宣言します。			
製品:	AR, ARC, ARG, ARG, AW, CL, CLC, CW, CWC, DR, DRC, FRAS, GR, GRC, HP, HPC, HW, HWC, LPG, LPGC, OA, OAC, OG, OGC, OMP, OMPC, RO, ROC, RY, RYC, WD, WDC の各種 Retracta ホースリールモデル		
指令:	2006/42/EC	(機械指令)	
	2009/127/EC	(指令の修正 - WD, DR, DRC モデルのみ)	
仕様:	EN ISO12100: 2010 (機械の安全性)		
私は、上記の製品が上記仕様の関連セクションに適合するように設計されていることをここに宣言します。この製品は、本指令のすべての必須要求事項に準拠しています。			
署名:			
	Marco Uccellani, 技術管理者, Macnaught Pty Ltd		
住所:	Macnaught Pty Ltd, 41-49 Henderson Street, Turrella, NSW 2205, Australia.		
日付:	2021年08月26日		
			

**EN (English)** Declaration of Conformity

We: Macnaught Pty Ltd Of: 41-49 Henderson Street, Turrella NSW 2205, Australia

Declare that: Retracta Hose Reel models prefixed AR, ARC, ARG, ARG, AW, CL, CLC, CW, CWC, DR, DRC, FRAS, GR, GRC, HP, HPC, HW, HWC, LPG, LPG, OA, OAC, OG, OGC, OMP, OMP, RO, ROC, RY, RYC, WD & WDC

In accordance with: 2006/42/EC (The Machinery Directive)  
2009/127/EC (amending Directive - WD, DR & DRC models only)

has been designed and manufactured to the following specifications:  
EN ISO 12100: 2010 (Safety of Machinery)

I hereby declare that the equipment named above has been designed to comply with the relevant sections of the above referenced specification. The product complies with all essential requirements of the Directives.

Signed By:   
Marco Uccellani, Engineering Manager, Macnaught Pty Ltd.

Done at: Macnaught Pty Ltd, 41-49 Henderson Street, Turrella, NSW 2205, Australia.

Date: 26/08/2021



**FR (French)** Déclaration de conformité

Nous, Macnaught Pty Ltd, 41-49 Henderson Street, Turrella NSW 2205, Australie

Déclarons que: Les modèles d'enrouleurs de tuyaux Retracta aux préfixes AR, ARC, ARG, ARG, AW, CL, CLC, CW, CWC, DR, DRC, FRAS, GR, GRC, HP, HPC, HW, HWC, LPG, LPG, OA, OAC, OG, OGC, OMP, OMP, RO, ROC, RY, RYC, WD et WDC

en vertu de: 2006/42/CE (directive Machines)  
2009/127/CE (directive modificative - modèles WD, DR et DRC uniquement)

sont conçus et fabriqués selon la spécification suivante:  
EN ISO12100: 2010 (sécurité Machines)

Je déclare par la présente que les équipements mentionnés ci-dessus sont conformes aux sections appropriées de la spécification susmentionnée. Le produit est conforme à toutes les exigences principales des directives.

Signé par:   
Marco Uccellani, responsable de l'ingénierie, Macnaught Pty Ltd.

Fait à: Macnaught Pty Ltd, 41-49 Henderson Street, Turrella, NSW 2205, Australie

Date: 26/08/2021



**DE (German)** Konformitätserklärung

Wir, Macnaught Pty Ltd mit Sitz in: 41-49 Henderson Street, Turrella NSW 2205, Australien

erklären, dass die Retracta Schlauchtrommelmodelle mit den Präfixen AR, ARC, ARG, ARG, AW, CL, CLC, CW, CWC, DR, DRC, FRAS, GR, GRC, HP, HPC, HW, HWC, LPG, LPG, OA, OAC, OG, OGC, OMP, OMP, RO, ROC, RY, RYC, WD und WDC

In Übereinstimmung mit den Verordnungen: 2006/42/EG (Maschinenrichtlinie)  
2009/127/EG (Änderungsrichtlinie, nur Modelle WD, DR und DRC)

gemäß folgenden Spezifikationen konzipiert und hergestellt worden sind:  
EN ISO12100: 2010 (Maschinensicherheit)

Ich erkläre hiermit, dass die oben genannten Geräte so konzipiert wurden, dass sie mit den einschlägigen Abschnitten der oben genannten Spezifikation übereinstimmen. Das Produkt erfüllt alle grundlegenden Anforderungen der Richtlinien.

Unterzeichnet von:   
Marco Uccellani, Manager Ingenieurwesen, Macnaught Pty Ltd.

Unternehmen, Ort: Macnaught Pty Ltd, 41-49 Henderson Street, Turrella, NSW 2205, Australien.

Datum: 26/08/2021



**ES (Spanish)** Declaraciones de

Nosotros: Macnaught Pty Ltd De: 41-49 Henderson Street, Turrella NSW 2205, Australia

Declaramos: Modelos Retracta Hose Reel con prefijo AR, ARC, ARG, ARG, AW, CL, CLC, CW, CWC, DR, DRC, FRAS, GR, GRC, HP, HPC, HW, HWC, LPG, LPG, OA, OAC, OG, OGC, OMP, OMP, RO, ROC, RY, RYC, WD & WDC

en conformidad con: 2006/42/EC (La Directiva sobre maquinaria)  
2009/127/EC (Directiva modificativa: solo los modelos WD, DR y DRC)

ha sido diseñada y fabricada de acuerdo con las siguientes especificaciones:  
EN ISO 12100: 2010 (Seguridad de la maquinaria)

Por la presente declaro que el equipo mencionado anteriormente ha sido diseñado para cumplir con las secciones pertinentes de las especificaciones mencionadas con anterioridad. El producto cumple con todos los requisitos esenciales de las Directivas.

Firmado por:   
Marco Uccellani, Responsable de ingeniería, Macnaught Pty Ltd.

Redactado en: Macnaught Pty Ltd, 41-49 Henderson Street, Turrella, NSW 2205, Australia.

Fecha: 26/08/2021



**JP (Japanese)** 保証書

当社: Macnaught Pty Ltd 所在地: 41-49 Henderson Street, Turrella NSW 2205, Australia

は、次の製品が以下の指令及び仕様に準拠して設計、製造されていることを宣言します。

製品: AR, ARC, ARG, ARG, AW, CL, CLC, CW, CWC, DR, DRC, FRAS, GR, GRC, HP, HPC, HW, HWC, LPG, LPG, OA, OAC, OG, OGC, OMP, OMP, RO, ROC, RY, RYC, WD, WDC の各種 Retracta ホースリールモデル

指令: 2006/42/EC (機械指令)  
2009/127/EC (指令の修正 - WD, DR, DRC モデルのみ)

仕様: EN ISO12100: 2010 (機械の安全性)

私は、上記の製品が上記仕様の関連セクションに適合するように設計されていることをここに宣言します。この製品は、本指令のすべての必須要求事項に準拠しています。

署名:   
Marco Uccellani, 技術管理者, Macnaught Pty Ltd

住所: Macnaught Pty Ltd, 41-49 Henderson Street, Turrella, NSW 2205, Australia.

日付: 2021年08月26日



SAFETY

TECHNICAL DETAILS

INSTALLATION

OPERATIONS

MAINTENANCE

TROUBLESHOOTING

COMPLIANCE

LIMITED WARRANTY



**LUBE**  
**Control**

Lube Control Pty Ltd

SAFETY

## LIMITED WARRANTY

TECHNICAL  
DETAILS

INSTALLATION

OPERATIONS

MAINTENANCE

TROUBLESHOOTING

COMPLIANCE

LIMITED  
WARRANTY



Lube Control Pty Ltd



**Macnaught**

**Macnaught Americas**



This product should be disposed of according to all applicable local and national government environment regulations and guidelines.