



## PORTABLE DIESEL TANK 400LTR 12V

MODEL NO: **DD400**

Thank you for purchasing a STM product. Manufactured to a high standard, this product will, if used according to these instructions, and properly maintained, give you years of trouble free performance.

**IMPORTANT:** PLEASE READ THESE INSTRUCTIONS CAREFULLY. NOTE THE SAFE OPERATIONAL REQUIREMENTS, WARNINGS & CAUTIONS. USE THE PRODUCT CORRECTLY AND WITH CARE FOR THE PURPOSE FOR WHICH IT IS INTENDED. FAILURE TO DO SO MAY CAUSE DAMAGE AND/OR PERSONAL INJURY AND WILL INVALIDATE THE WARRANTY. KEEP THESE INSTRUCTIONS SAFE FOR FUTURE USE.



Refer to instructions



Wear protective gloves



Wear protective clothing



Wear safety footwear

### 1. SAFETY

- ❑ **WARNING!** this tank must **ONLY** be used for diesel fuel.
  - ✓ Place the tank on a flat surface before filling.
  - ✓ Secure the tank to strong points with ratchet straps before transporting in or on a vehicle.
  - ✓ Maintain the pump in good condition (use an authorised service agent).
  - ✓ Replace or repair damaged parts. *Use recommended parts only. Non authorised parts may be dangerous and will invalidate the warranty.*
  - ✓ Keep the pump clean for best and safest performance.
  - ✓ Ensure the power supply (vehicle battery) corresponds with the requirements of the pump (12V DC).
  - ✓ Disconnect from battery when not in use.
  - ✓ Wear protective gloves, and protective clothing when working around fuel.
  - ✓ Keep children and unauthorised persons away from the working area.
- \* **DO NOT** place the tank near any heat source.
  - \* **DO NOT** start or stop the pump by connecting or disconnecting the battery clamps.
  - \* **DO NOT** allow the unit to get wet.
  - \* **DO NOT** operate the pump with wet hands.
  - \* **DO NOT** use the pump where explosive or flammable vapours may be present.
  - \* **DO NOT** tamper with the pump connections.

### 2. INTRODUCTION

Manufactured from HDPE for the safe transportation and dispensing of diesel fuel when supplying on site equipment. Complies to ADR 1.1.3.1.C for exemption from requirements of ADR regulations. Supplied with a 12V electric pump, 4mtr electric cable and clamps and a 4mtr delivery hose with automatic fuel nozzle. Can be safely secured and transported on a pick-up truck or van, using grooves for tie-down straps and 6 handles for positioning. Supplied with lockable cover. Not suitable for petrol.

### 3. SPECIFICATION

Model No: ..... **DD400**  
 Voltage: ..... 12V  
 Current: ..... 15A  
 Power: ..... 180W  
 Tank Capacity: ..... 400ltr  
 Flow Rate: ..... 20ltr/min  
 Duty Cycle: ..... 30mins on/30mins off  
 Dimensions (W x D x H): ..... 1100 x 800 x 720mm  
 Nett Weight: ..... 43.16kg

#### Key: (fig.1. & fig.1A).

- 1 ..... Breather Lid
- 2 ..... Pump On/Off Switch
- 3 ..... Battery Clips
- 4 ..... Automatic Fluid Nozzle
- 5 ..... Securing Strap Locations
- 6 ..... Vent Plug
- 7 ..... Fork Locations
- 8 ..... Moulded Hand Holds

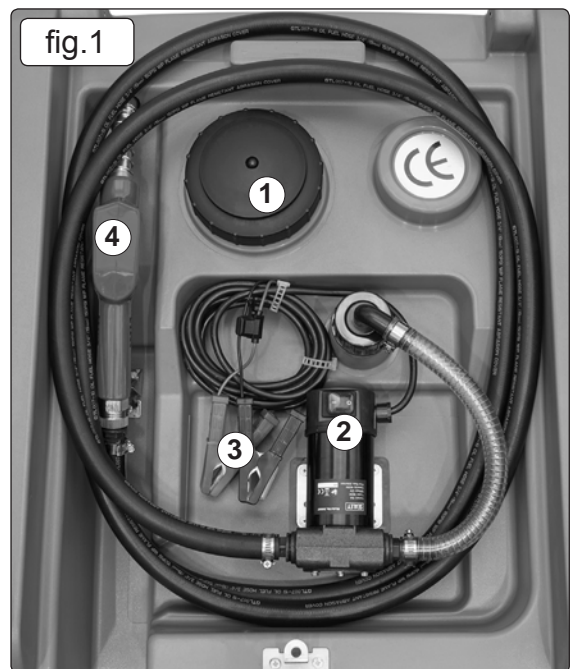



#### 4. OPERATION

##### 4.1. TRANSPORT

- 4.1.1. Move the empty tank assembly with two persons using the hand holds moulded into the base of the unit (fig.1A.8).
- 4.1.2. Move by forklift truck using the fork locations shown in (fig.1A.7). Ensure that the filler (fig.1A.1) is closed before moving.
- 4.1.3. Secure the tank to the carrying vehicle by ratchet straps. Locations for the straps are moulded into the tank (fig.1A.5).

##### 4.2. FILLING

- 4.2.1. **DO NOT** run the pump without fuel in the tank. To do so will damage the pump's internal components and will invalidate your warranty.
- 4.2.2. The tank is filled by unscrewing the filler (fig.1.1) in an anticlockwise direction. Refit the filler cap immediately after filling.
  - **WARNING** take care not to overfill the tank.

##### 4.3. FUEL DISPENSING

- 4.3.1. Before connecting to a battery, make sure that the pump switch (fig.5.2) is in the 'off' (O) position. Connect the battery clips to the 12V battery, observing correct polarity (red clamp to +ve terminal, black clamp to -ve terminal)
- 4.3.2. Switch the pump switch to the 'on' (I) position.
- 4.3.3. Unwind sufficient hose and place the nozzle (fig.4) in the receiving tank and pull the trigger (fig.4). Delivery will commence and continue until the trigger is released.
- 4.3.4. The trigger can be locked in one of three positions by engaging the latch (fig.4) to hold the trigger open. **DO NOT** leave the nozzle unattended with the trigger latched open.
- 4.3.5. Slight pressure on the trigger will release the latch.
- 4.3.6. When the level in the receiving tank reaches the nozzle, delivery will stop automatically.
- 4.3.7. When delivery is complete, switch off the pump. Ensure the hose is wound into its housing on the tank and that the nozzle is secured in its storage place.
- 4.3.8. **DO NOT** operate the pump continuously for more than 30 minutes. The duty cycle of the unit is 30 minutes, after which the motor must be left to cool down for a further 30 minutes.
- 4.3.9. **DO NOT** run the unit for more than 2-3 minutes with the delivery nozzle closed.

#### 5. MAINTENANCE

- 5.1. The pump contains no user-servicable parts. Repairs should only be undertaken by competent persons.
- 5.2. Check the integrity of all the hose connections periodically. If any leakage is evident, strip the joint and wind PTFE tape around the male thread.
- 5.3. Check all electrical connections and cables for wear and damage. Rectify any faults found.
- 5.4. Keep clean, especially the dispenser nozzle.
  - ✓ Clean with a damp, soapy cloth.
  - × **DO NOT** use abrasive or solvent cleaners.

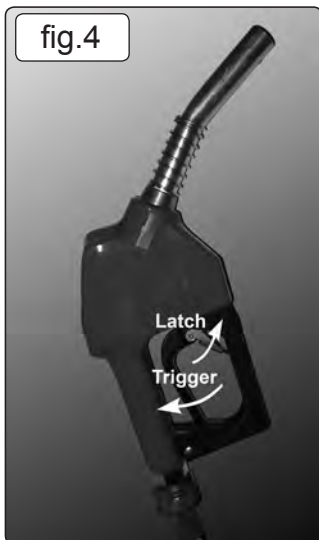

#### ENVIRONMENT PROTECTION

Recycle unwanted materials instead of disposing of them as waste. All tools, accessories and packaging should be sorted, taken to a recycling centre and disposed of in a manner which is compatible with the environment. When the product becomes completely unserviceable and requires disposal, drain any fluids (if applicable) into approved containers and dispose of the product and fluids according to local regulations.

**Note:** It is our policy to continually improve products and as such we reserve the right to alter data, specifications and component parts without prior notice.

**Important:** No Liability is accepted for incorrect use of this product.

**Warranty:** Guarantee is 12 months from purchase date, proof of which is required for any claim.

Parts Information:  
**Portable Diesel Tank 12V**  
**Model No: DD400**

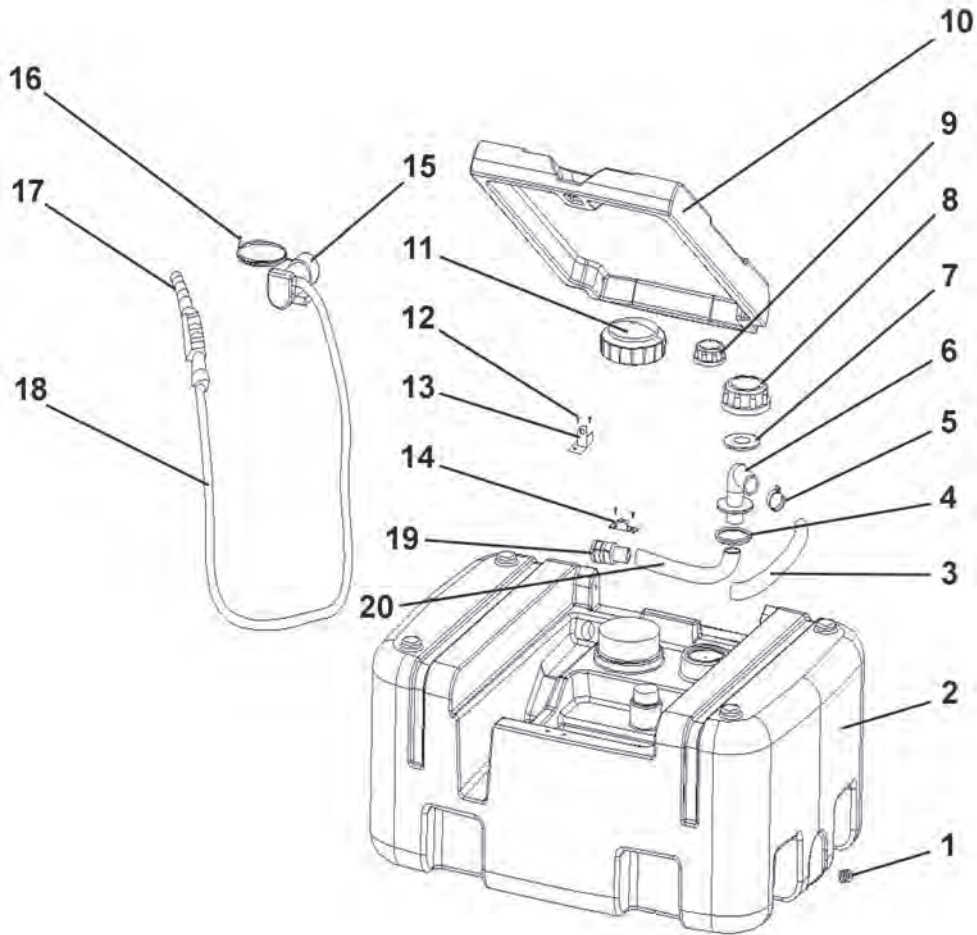

Item	Part No.	Description
1	D400T.01	Vent Plug
2	D400T.02	Tank 400ltr ( <b>for DD400 only</b> )
--	D200T.02	Tank 200ltr ( <b>for DD210 only</b> )
3	D400T.03	3/4" Connection Hose
4	D400T.04	Lower Seal for Suction Elbow
5	D400T.05	Hose Clip
6	D400T.06	Suction Elbow
7	D400T.07	Upper Seal for Suction Elbow
8	D400T.08	Suction Cap
9	D400T.09	Level Gauge
10	D400T.10	Tank Lid ( <b>for DD400 only</b> )

Item	Part No.	Description
--	D200T.10	Tank Lid ( <b>for DD210 only</b> )
11	D400T.11	Beathing Cap
12	MSP610.S	Machine Screw Pan Head Phillips M6 x 10mm
13	D400T.13	Nozzle Holder
14	D400T.14	Tank Lid Lock Holder
15	D400T.15	Electric Pump 12V
16	D400T.16	Bracket for Electric Pump
17	D400T.17	Automatic Fluid Nozzle
18	D400T.18	Delivery Hose 4m
19	D400T.19	Filter
20	D400T.20	Hose

**NOTE:** It is our policy to continually improve products and as such we reserve the right to alter data, specifications and component parts without prior notice.

**IMPORTANT:** No liability is accepted for incorrect use of product. Spare parts must be fitted by a competent person

**WARRANTY:** Guarantee is 12 months from purchase date, proof of which will be required for any claim.