



**LUBE**  
Control

Lube Control Pty Ltd

**STM**<sup>®</sup>

## DC/AC Fuel Transfer Pumps Instruction Manual

---



**WARNING:**

Read carefully and understand all **INSTRUCTIONS** before operating. Failure to follow the safety rules and other basic safety precautions may result in serious personal injury. Save these instructions in a safe place and on hand so that they can be read when required. Keep these instructions to assist in future servicing.

---

REV 05/24/17



**LUBE  
Control**

Lube Control Pty Ltd



## GENERAL SAFETY REGULATIONS



**WARNING:** The warnings, cautions, and instructions discussed in this instruction manual cannot cover all possible conditions or situations that could occur. It must be understood by the operator that common sense and caution are factors that cannot be built into this product, but must be supplied by the operator.

1. Keep the work area clean and dry. Damp or wet work areas can result in injury.
2. Keep children away from work area. Do not allow children to handle this product.
3. Use the right tool for the job. Do not attempt to force small equipment to do the work of larger industrial equipment. There are certain applications for which this equipment was designed. It will do the job better and more safely at the capacity for which it was intended. Do not modify this equipment, and do not use this equipment for a purpose for which it Was not intended.
4. Check for damaged parts. Before using this product, carefully check that it will operate properly and perform its intended function. Check for damaged parts and any other conditions that may affect the operation of this product. Replace damaged or worn parts immediately.
5. Do not overreach. Keep proper footing and balance at all times to prevent tripping, falling, back injury, etc.
6. DO NOT use the equipment when tired or under the influence of drugs, alcohol, or medication. A moment of inattention while operating this equipment may result in serious personal injury



### TECHNICAL DETAILS

Item No.	Electrical Power		Flow Rate GPM/LPM	Nozzles
	Current	Voltage		
10305700	DC	12	15/57	Manual
10305701	DC	24	15/57	Manual
10307600	DC	12	20/76	Manual
10307601	DC	24	20/76	Manual
10305702	AC	120	15/57	Manual
10305720	AC	230	15/57	Manual
10305723	DC	12	15/57	Automatic
10305724	DC	24	15/57	Automatic
10305725	AC	120	15/57	Automatic
10305726	AC	230	15/57	Automatic

### TECHNICAL INFORMATION

- Inlet: 2" male on tank adapter, 1" female on pump
- Outlet:
  - 3/4" female for 15GPM/57LPM
  - 1" female for 20GPM/76LPM
- Built-in bypass valve
- Furnished with:
  - 13ft/4m delivery hose
  - 1pc steel suction pipe
  - 1pc Aluminum manual nozzle
  - 2" Quick change coupling

### SAFETY PRECAUTIONS

To ensure safe and efficient operation, it is essential to read and follow each of these warnings and precautions.

1. DO NOT smoke near pump or use pump near an open flame. Fire could result.
2. Disconnect power to pump before servicing pump.
3. Turn off the switch before connecting power.
4. Take motors needing service to an authorized repair shop or return to factory to maintain.
5. A filter should be used on pump outlet to ensure that no foreign material is transferred to fuel tank.
6. Tank or barrel should be anchored to prevent tipping in both the full and empty conditions.



#### WARNING

1. Electrical wiring should be done a licensed electrician in compliance with local codes. Rigid conduit should be used and proper ground must be provided to avoid the possibility of electrical shock. Failure to comply with this warning could result in serious injury and/or loss of property.
2. This product should not be used for fluid transfer into aircraft. This product is not suited for use with fluids for human consumption or fluids containing water.
3. Extreme operating conditions with working cycles longer than 30 minutes can cause the motor temperature to rise, thus damaging the motor itself. Each 30-minute working cycle should always be followed by a 30-minute power-off cooling phase.
4. **MAXIMUM BY-PASSING TIME: 3 MINUTES.**
5. **DO NOT RUN DRY OVER 30 SECONDS.**

### GENERAL DESCRIPTION

These products are positive displacement, rotary vane pumps. Depending on installation and viscosity, these pumps can deliver up to 20GPM or 76 LPM. Their rugged design makes for a long life of dependability.



**LUBE  
Control**

**Lube Control Pty Ltd**

TECHNICAL  
DETAILS

## OPERATION

### OPERATING CONDITIONS

- Temperature: min -20°C / max +60°C
- Relative Humidity: max 90%

SAFETY  
PRECAUTIONS

### FLUID COMPATIBILITY

These products are compatible with the following fluids:

**Diesel, Kerosene, Mineral Spirits**

Do NOT use with other fluids without consulting manufacturer.

OPERATION

## INSTALLATION

1. Tightly screw suction pipe into inlet coupling of pumping unit. Extend suction pipe into truck tank or barrel to within 3" of tank bottom.
2. Screw inlet coupling of pump into 2" tank or barrel opening. Inlet coupling must be completely and securely threaded into an undamaged tank or barrel bung.
3. During installation and maintenance, make sure that the electric supply lines are not live.
4. Always turn off the switch before supplying electrical power.
5. Check the correct rotation direction of the DC pump. If it is inverted, check the polarity of the connection cable.
  - a) RED cable: positive pole (+)
  - b) BLACK cable: negative pole (-)
6. Systems should be designed to require a minimum amount of suction lift. Maximum "equivalent feet of lift" is 8' for diesel fuel.
7. Tank or barrel must be properly vented. A water separator should be used for pumping diesel fuel.
8. Power to the unit should be supplied from a dedicated 30 amp circuit breaker. No other equipment should be powered from this breaker. If two pumps are supplied from one breaker, that breaker must be capable of handling the load of both motors.

INSTALLATION

PROBLEMS AND  
SOLUTIONS

MAINTENANCE

EXPLODED AND  
PARTS LIST

E2

**PROBLEMS AND SOLUTIONS**

Problem	Possible Cause	Corrective Action	
The motor is not turning	Lack of electric power	Check the electrical connections and the safety systems	
	Rotor jams	Check for possible damage or obstruction of the rotating components.	
	Motor problems	Contact with the service department	
	Thermal overload protection shut	Move ON/OFF lever to the "OFF" position to reset pump.	
Low or no flow rate	Low level in the suction tank	Refill the tank	
	Foot valve blocked	Clean and/or replace the valve	
	Filter clogged	Clean the filter	
	Excessive suction pressure	Lower the pump with respect to the Level	
	High loss of head in the circuit (working with the by-pass open)	Use shorter tubing or of greater Diameter	
	By-pass valve blocked	Dismantle the valve, clean and/or replace it	
	Air entering the pump or the suction tubing	Check the seals of the connections	
	A narrowing in the suction Tubing	Use tubing suitable for working under suction pressure	
	Low rotation speed		Check the voltage at the pump.
			Adjust the voltage and/or use cables of greater cross-section
	The suction tubing is resting on the bottom of the tank	Raise the tubing	
Increased pump noise	Cavitations occurring	Reduce suction pressure	
	Irregular functioning of the by-pass	Dispense until the air is purged from the circuit	
Leakage from the pump body	Air present in the diesel fuel	Verify the suction connections	
	Seal damaged	Check and replace the mechanical seal	

**Daily Use**

- If using flexible tubing, attach the ends of the tubing to the tanks. In the absence of an appropriate slot, solidly grasp the delivery tube before beginning dispensing.
- Before starting the pump make sure that the delivery valve is closed (dispensing nozzle or line valve).
- Turn the ON/OFF switch to ON. The by-pass valve allows functioning with the delivery closed for only brief periods.
- Open the delivery valve, solidly grasping the end of the tubing.
- Close the delivery valve to stop dispensing.
- When dispensing is finished, turn off the pump.

**MAINTENANCE**

Under normal working conditions the noise emission from all models does not exceed the value of 80 db at a distance of 1 meter from the electric pump.



**LUBE  
Control**

Lube Control Pty Ltd

TECHNICAL  
DETAILS

SAFETY  
PRECAUTIONS

OPERATION

INSTALLATION

PROBLEMS AND  
SOLUTIONS

MAINTENANCE

EXPLODED AND  
PARTS LIST

**EXPLODED AND PARTS LIST**

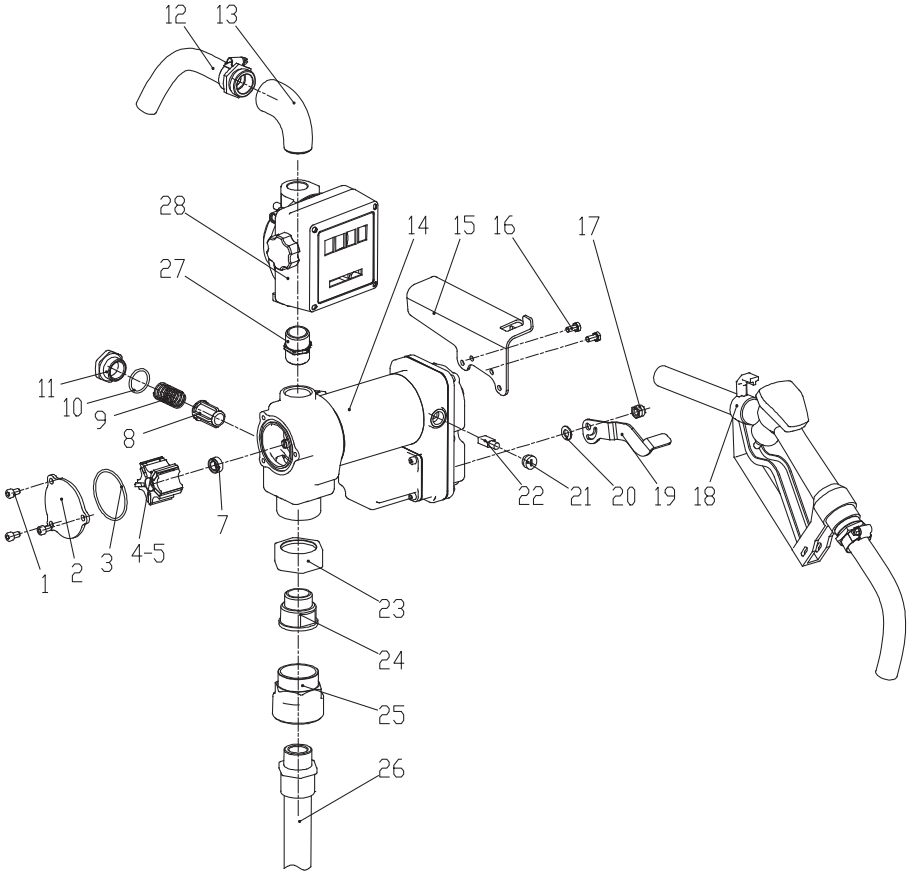

Part No.	Description	Q'ty	Part No.	Description	Q'ty
1	SCREW M6×10	3	16	SCREW M6×10	2
2	FRONT COVER	1	17	NUT	1
3	O-RING	1	18	NOZZLE	1
4	BLADE	5	19	NOZZLE BRACKET	1
5	ROTOR	1	20	GASKET	1
7	Seal	1	21	END CAP	2
8	BYPASS VALVE	1	22	CARBON BRUSH	2
9	SPRING	1	23	NUT	1
10	O-RING	1	24	ADAPTER	1
11	NUT OF RELIEF VALVE	1	25	TANK ADAPTOR	1
12	DELIVERY PIPE	1	26	EXTENSIBLE PIPE	1
13	ELBOW	1	27	SWIVEL	1(OPTION)
14	PUMP	1	28	MECHANICAL METER	1(OPTION)
15	NOZZLE COVER	1			

**E4**



**LUBE**  
Control

Lube Control Pty Ltd

**STM**®