



# Fuel Transfer Pump Kit (Mechanical Meter) User's Manual



 **WARNING:** Read carefully and understand all **INSTRUCTIONS** before operating. Failure to follow the safety rules and other basic safety precautions may result in serious personal injury.

**Model No. 10308003, 10307204, 10305603, 10306600, 10308200**



## A. DECLARATION OF CONFORMITY

### DECLARATION OF CONFORMITY

#### IN ACCORDANCE WITH THE DIRECTIVES:

89/392/CEE - 91/368/CEE - 93/44/CEE – 89/336/CEE – 92/31/CEE

DECLARES THAT THE FOLLOWING PUMP MODELS:

**10308003, 10307204, 10305603, 10306600, 10308200**

To which this declaration refers, conform to the following applicable regulations:

EUROPEAN REGULATIONS:

EN292-1-92 – Safety of Machinery – General Concepts, basic principles for design – terminology, basic methodology

EN292-2-92 – Safety of Machinery – General Concepts, basic principles for design – specifications and technical principles

EN294-93 – Safety of Machinery – safe distances to prevent the operator's upper limbs from reaching dangerous areas

EN60034-1-2000 – Rotating electrical Machinery – nominal and functional specifications

EN60034-5-2001 – Classification of grades of protection for the housings of rotating electrical machinery

EN61000-6-3 – Electro – magnetic compatibility – generic emission standards

EN61000-6-1 – Electro – magnetic compatibility – generic immunity standards

EN55014-1-00(A1/99-A2/99) limits and methods for measuring radio disturbance characteristics

EN55014-2-97 – Electrical motor – operated and thermal appliances for household and similar purposes, electric tools and similar electrical apparatus

EN60204-1-98 – safety of machinery – electrical equipment of machines

## B. INTRODUCTION

The diesel transfer pump kit has been designed for the delivery of diesel & kerosene from an open surface tank. This manual, apart from giving all necessary information on ordinary maintenance and supporting engineers in failure detection and repair, should also give all the information's needed to fully employ the capacity of the machine, as well as to the user's needs.

### INSTALLATION

Electric connection should be done on a CEI standard socket provided with switch (so it isn't live when the connection is done) according to L.46/90 prescriptions.

### PRELIMINARY INSPECTIONS

Before the power connection is done, verify the conductors aren't live and general switches are off.

### DISMANTLING AND DISPOSAL PROCEDURE

The metallic parts which the machine is mainly made of will be dismantled and sent to the steel mills. The fuels in the tanks of the installation will be collected and sent to an authorized disposer. All plastic and non-degradable material parts will be separately collected and sent to an authorized disposer or recycled.

#### SAFETY DEVICES

- **General Switch**

It is placed on the motor body and allows the operator to set it on standby in a very short time. Once the machine is stopped, the whole starting procedure can be repeated.

- **Mechanical Protections**

They are metal protections meant to prevent access to mechanical moving parts, high-temperature parts and live electric parts.

- **Harmful Functions**

The noise from the machine is below 70 dB (A).

- **HARMFUL EMISSIONS**

Steam emission is so reduced to result irrelevant.

- **FIRE PREVENTION**

In case of fire never use water, but extinguishing powders charged with CO2 cat. A-B-C-D only, employing the extinguishers placed next to the machine. Combustion of paints and plastic parts may produce toxic emissions: use the normal precautions to be employed in case of fire (always refer to the security supervisor of the place of installation).

**NOTICE: THE VISION IS BUILT PAYING MAXIMUM CARE TO USER'S AND MAINTENANCE ENGINEER'S SECURITY.**

### C. TECHNICAL DATA

PUMP MODEL	Flow Rate	ELECTRICAL POWER			POWER
		Current	Voltage(V)	Frequency	Nominal (Watt)
10308003	80LPM/22GPM	AC	230	50/60	450
10307204	72LPM/19GPM	AC	230	50/60	450
10305603	56LPM/15GPM	AC	230	50/60	370
10306600	66LPM/18GPM	AC	120	60	370
10308200	22LPM/22GPM	AC	120	60	450

### D. PRECAUTIONS

**During Diesel delivery** always wear oil resistant and always wash hands with water and soap at the end.  
**Always clean** at once oil stains to avoid slips and/or pollution.



**Use particular care** with the zones next to the controls.

**When cleaning**, and specially when removing dust or waste, always wear suitable clothes, if possible use aspirators only. Always use suitable clothes or protective devices. Never place hands or limbs under moving parts.

## E. SYSTEM DESCRIPTION

### Functional Description

The diesel transfer system are hydraulic machine tools which feed with a given capacity (volume) of fluid in the time unit, a collecting tank, sucking the liquid from an open surface feed tank; the allowed suction lift (geodetic suction lift H<sub>ga</sub>) is also a specific characteristic of the pump. The system is composed by complementary equipment, operating as whole to give a complete service:

- Feeding pump
- Volumetric flow meter
- Suction kit (Diesel hose with filter)
- 4M delivery hose
- 1pc dispensing nozzle

## F. ALLOWED AND FORBIDDEN USE

Diesel transfer unit has been designed and built for DIESEL TRANSFER ONLY from reservoirs, tanks and drums.

**It is strictly forbidden to employ it to transfer liquids of different kind as gasoline, explosives and corrosives (or flammable), alimentary liquids.**

**The machine isn't designed for employment in the explosive environment.**

**Operating the pump is forbidden to children and disabled person.**

**It is forbidden to employ the unit next to flammable liquids (gasoline, alcohol, etc.).**

**It is forbidden the employment in closed environments in presence of gasoline, LPG, methane fuelled vehicles.**

## G. TRANSPORT AND UNPACKING

Due to its weight and dimensions, the unit can easily be transported by hand. Control that the package is good conditions and verify that the unit isn't damaged. Each failure must be noticed in 10 days from receiving the machine.

For correct unpacking carefully follow these instructions:

1. Place the case on the ground following the indications on the package.
2. Carefully open the case, remove the machine and place it on the ground or on a steady surface.
3. Control that the machine and its accessories aren't damaged.
4. Fasten the panel, placing it on the ground or on a steady surface capable of carrying the pump, in a repaired environment with a temperature between +40°C and -20°C well lit and ventilated. For a better employment the unit should be placed as near as possible to level of liquid to be pumped. (Max. distance 2m)
5. Screw the delivery hose on the fitting of the flow meter and of the filling gun.



6. We suggest using a diesel resistant rubber or plastic suction hose; spiral shaped, with minimum as 25mm internal diameter, the same as the union. The hose must be sealed to avoid leaks. In case a 4 meters or longer hose is employed we suggest to use the foot valve with filter.

## H. USE AND STARTING

### POWER GRID ELECTRICAL CONNECTION (220V)

The plant must be provided with a safety device of 30mA minimum Din standard. The plug must be connected to an earthed SHUKO socket. It is forbidden to cut or replace the provided plug.

### STARTING

Once the hoses are sealed, the feeding cable is connected and the filling gun is in rest position, the machine can be started.

After placing the hose into the tank and the gun into the filling hole, start the pump, gradually move the switch to "ON" and start fuel transfer pump kit. Once the filling is done, release the control of the nozzle and switch the pump off. Then put the nozzle back to the holder.

### FLOW METER

The flow meter shows how many litres of liquid were pumped by the unit. Be aware that this device is not suitable to measure products for resale.

The mechanical flow meters indicate the partial (resettable) and total (no reset function) of the litres pumped. Each time the instrument must be reset, turn the knob on the left of the unit until all zeroes are displayed.

#### Calibration

The meter used in the pumping unit is calibrated at the factory. Calibration is recommended upon initial use, after disassembly or significant wear. Meter calibration can be easily changed with the procedure hereafter. The proving container should be at least 50 litres.

Procedure:

Fill container to a know volume

Turn the calibration screw

+Clockwise to increase the number of liters counted

-Counterclockwise to decrease the number of liters counted

## WARNINGS

1. The gunlock has been provided to make filling easier. It is forbidden to leave the gun unattended to avoid overflow.
2. Don't operate the machine if there is no liquid inside. Don't start the pump before connecting suction and delivery hoses.
3. Once the gun is closed switch the motor pump off as soon as possible. THE PUMP HAS TO WORK IN BY-PASS CONDITION FOR SHORT PERIOD: MAXIMUM 3 MINUTES.
4. In case of current losses the pump should be switched off and the plug disconnected.
5. It is strictly forbidden to use the pump with wet hands, barefooted or dipped in water.
6. In case of blackout switch the pump off and disconnect the plug to avoid unexpected starts with liquid overflow.

7. When transferring from open-air tanks, we suggest to place the machine as far as possible to avoid sprays and sudden dips which may cause serious damage.

## I. MAINTENANCE

Each kind of disassembly should always be carried out when the machine is stopped, the plug is disconnected and after emptying the pump and the flow meter. For a better operation control every three months that there isn't any kind of debris in the flow meter filter.

## J. OPERATIONAL PROBLEMS

ACCIDENTS	CAUSES	REMEDIES
The pump doesn't work	A) Jammed shaft B) No electric feeding	A) Disconnected the plug; unscrew on the pump, remove the pump body and clean it inside. Control that the shaft is now working correctly. Reassemble the pump. B) Control that the plug is correctly connected and that the socket is live.
The pump works doesn't deliver liquid.	A) The pump sucks air from the suction hose. B) Air inside the pump	A) Control the suction hose seal on the pump. Verify that the hose is completely immersed into the liquid and free from chokes. B) Control that the filter is clean. C) Ensure the suction height is less than 4M.

## K. MECHANICAL RISKS

1. Mechanical parts subject to wear

The blades

The bearing

The rotor

These parts should be replaced with original spare parts by qualified personal only or in authorized service centres.

2. Risks due to extreme temperatures

Remember that a very low temperature can freeze the Diesel inside the pump. This situation can cause serious damage to the motor pump unit.

3. A very high temperature (about 45°C) may cause the plastic parts in the unit to expand. The unit should thus be placed in a well-ventilated place and protected from the sun.



**L. DIAGRAM & PARTS LIST**

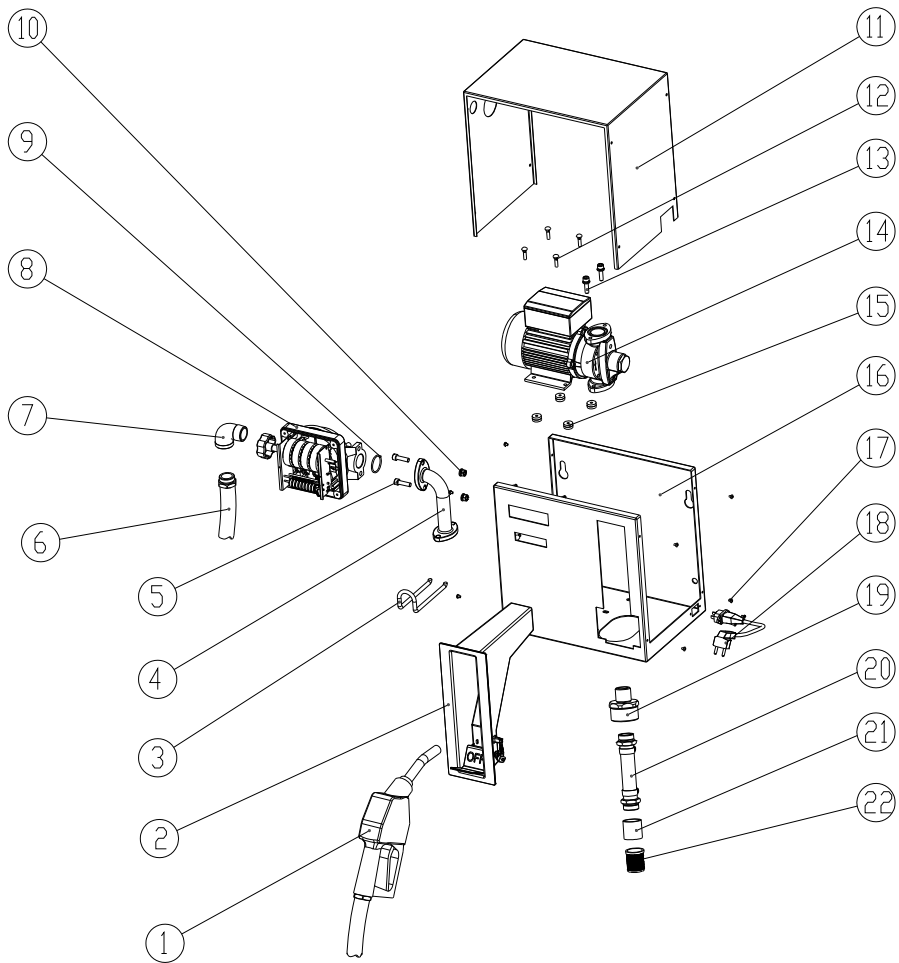

Part No.	Component description	Quantity	Part No.	Component description	Quantity
1	Automatic Nozzle	1	12	Bolt M6	4
2	Nozzle holder	1	13	Bolt M8	2
3	Hose Holder	1	14	AC Fuel Transfer pump	1
4	Fitting	1	15	Washer	4
5	Bolt M8	2	16	Bottom plate	1
6	Outlet	1	17	Bolt M4	8
7	Elbow	1	18	Power cord	1
8	Mechanical meter	1	19	Fitting	1
9	O-ring	1	20	Inlet	1
10	Nut M8	2	21	One-way valve	1
11	Cover Board	1	22	Filter Mesh	1

**NOTE: The parts following parts list showed are optional**



**LUBE**  
Control

Lube Control Pty Ltd

Part No.	Component description	Quantity
1	Manual Nozzle	1
19	Quick change coupling	1
21	One-way valve	1