



LUBE
Control

Lube Control Pty Ltd



LEADERS IN FLUID TRANSFER SOLUTIONS

3:1 Oil Pump & Oil Pump Kits

Manual





THE MANUAL OF OIL PUMP

Read the following precautions and instructions before you begin assembly or using. Failure to comply with these instructions could result in personal injury or property damage. Keep these instructions in a convenient location for future reference.

IMPORTANT NOTE:

The guarantee will be void if the pump has been altered in any way

PROFILE

Oil pumps can be used to transfer lubrication oil, waste oil and antifreeze liquids. This manual is applicable to the following pump only, please confirm your pump is included.

Specification

Item No.	DIT11701031	DIT11701033
Compression ratio	3:1	
Operating pressure(bar/psi)	5-8/70-115	
Maximum pressure(bar/psi)	8/115	
Air consumption(L/min Gallon/min)	240/63.5	
Capacity(L/min Gallon/min)	12/3.2	
Tube diameter(mm/inch)	42/1.65	42/1.65
Suction tube length(mm/inch)	270/10.6 or Wall installed/ Extension transfer	940/37
Air inlet connection	1/4" quick plug 1/4" NPT female	
Oil delivery connection	Male 1/2"	
Max. viscosity oil delivered	SAE 150	
Temperature oil delivered	-10~50°C	
Noise level(dB)	82	



3:1 SERIES OIL PUMP EXPLODED VIEW

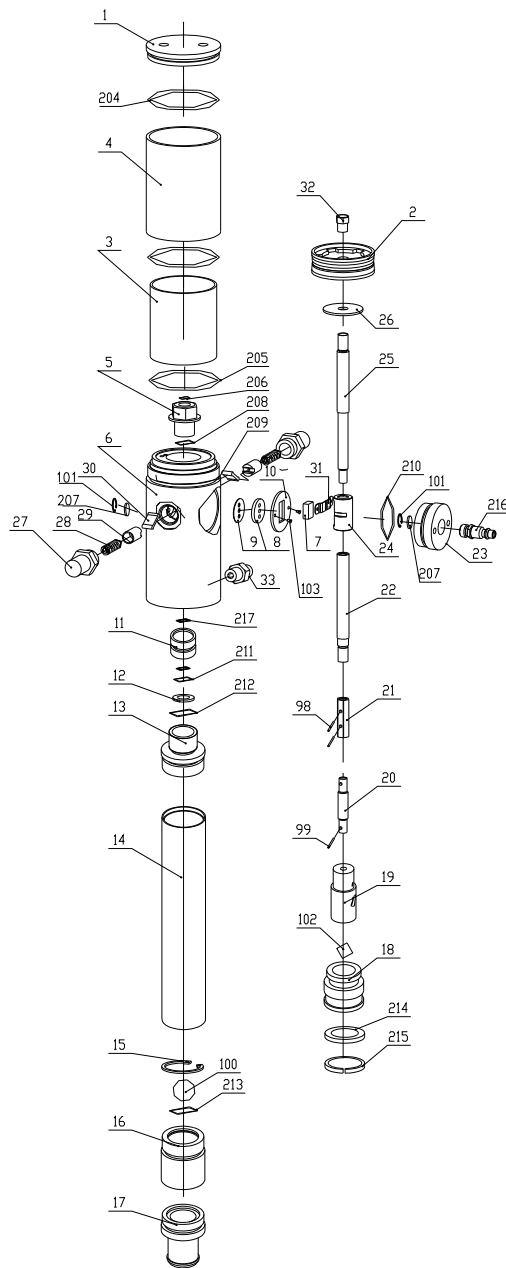



3:1 SERIES OIL PUMP PART LIST

Appendix

Code	Name	Quantity
1	Air motor cover	1
2	Piston	1
3	Air motor shell inside	1
4	Air motor shell outside	1
5	Bracket	1
6	Air control center	1
7	Slider	1
8	Gasket	1
9	Soft gasket	1
10	Securing washer	1
11	Bracket	1
12	Washer	1
13	Connect tube	1
14	Suction tube	1
15	Spring circlip	1
16	Valve seat	1
17	Filter or connector	1
18	Piston	1
19	Connecting shell	1
20	Connect shaft	1
21	Connect shell	1
22	Middle shaft	1
23	Air center cover	1
24	Slider shell	1
25	Piston shaft	1
26	Washer	2
27	Spring shell	2

Code	Name	Quantity
28	Spring	2
29	Spring seat	2
30	Trip shoe guide	2
31	Press piece	1
32	Nut	1
33	Outlet	1
98	Pin	2
99	Pin	1
100	Ball	1
101	Small circlip	2
102	Ball	1
103	Screw	2
204	O-ring	1
206	O-ring	2
207	Silencer	2
208	O-ring	1
209	O-ring	1
210	O-ring	1
212	O-ring	1
213	O-ring	1
214	U seal	1
215	Guiding	1
217	OD seal	1
205	O-ring	1
211	O-ring	1
216	Quick coupling	1

Troubleshooting

Problem	Possible Causes	Solutions
The pump continues to operate after the gun trigger has been released	1. There is an oil leak at some point of the circuit 2. Valve sets (part No. 11 or 18 and 214, 215) close incorrectly due to dirt or wearing.	1. Check and tighten unions. Repair the leak. 2. Substitute damaged elements
Reduction of the oil delivery. Or reduced pressure in the oil delivery.	1. Silencer (207) dirtied 2. Blocked at some point of the oil circuit 3. Ball valve (102) closes incorrectly due to dirt or wearing.	1. Clean or recharge silencer 2. Use clean oil 3. Substitute damaged elements
Air loss through their exhaust	1. The sliding valve (7) does not close properly 2. Damaged O-ring (204, 205, 206, 208, 209 or 211) 3. Damaged piston (2) 4. Damaged washer (26) 5. Broken spring (28)	1. Disassemble and clean. Substitute in case of damage 2. Substitute damaged elements
Oil leaks through their exhaust	Seal set (11) damaged	Substitute damaged elements

If the pump has anything wrong, please contact dealer or their technical supporter. We don't recommend customer repair the pump themselves.



LUBE
Control

Lube Control Pty Ltd

STORAGE AND MAINTENANCE

Pumps are delivered in appropriate cardboard boxes. Packaging material should be properly disposed.

Handling and storage of the new pump do not require any special procedures.

However after the pump has been used, empty the used oil in the suction tube into an appropriate container. This is done by overturning the pump

The dust in compressed air can slow down and even block the motor cylinder. The following steps may prevent this from happening:

- 1) Let in 50 gram of Vaseline oil or other lubricator from the air inlet hole weekly operate the pump for several minutes after having into the pump.
- 2) Turn on the pump for several minutes until moving parts is fully lubricated.
- 3) You may repeat the above operation if necessary.
- 4) The above steps should be carried out on a weekly base.

For the pumps that are attached with compressed air treatment equipment, please empty the water retained in the reservoir of the filter-purger frequently.

For the pumps that are attached with a lubricator, please pay close attention to the lubricator's oil level and refill with SAE 20, SAE 30 or antifreeze oil for extreme conditions when necessary.

NOTE:

The user should perform only routine maintenance operations (such as filters, silencers, cleaning...) with the pump in order not to damage it or compromise its safety. Contact our sales or service centers when the pump needs further maintenance.

GENERAL SAFETY REGULATIONS

When the pump is connected to the compressed air supply:

- The compressed air must be filtered to avoid dust and moisture into pump
- The max compressed air pressure must not exceed 0.8Mpa
- To deliver oil, press the knob on the delivery pistol; delivery stops when the knob is released but the whole system remains under pressure.
- Position the pistol so that the circuit can't open accidentally. Otherwise oil could leak onto the ground.
- Never point the pistol at people or objects.
- Press the pistol knob.
- Always cut off the air supply after use so that oil can't leak out in case one of the pump's components should break
- Use only original spare parts in case the pump has to be repaired or its components have to be replaced
- Empty all the oil from the pump in case it has to be disposed of.
- When not in use, turn off compressed air to stop pump.
- Do not use the pump near open flames. Do not smoke during this operation.
- Wear oil-proof gloves
- Do not throw the oil away. Used oil has to be disposed of according to national Environmental regulations
- The pumps can be used only to deliver lubricants, used oil or antifreeze liquids. Do not use the pump for any other substance.



HOW TO USE

DIRECTLY FITTED PUMPS INTO THE DRUM

1. Insert the suction tube of pump into the drum and secure with ring nut, suitable for commercial drums with 57 diameter hole and threading 2" BSP
2. Fit a oil delivery tube for oil outlet of the air operated pump using only high quality tubes (normally 1/2" or 3/4", according to DIN-SAE norms), by means of 1/2" BSP threading fitting.
3. Oil delivery pistol: Connect delivery tube with delivery pistol using suitable pipe fittings, and point the pistol at right place.
4. Air inlet connection is 1/4" quick plug (or 1/4" NPT female) in all versions. Compressed air connection (to be supplied by the customer) should be done using suitable tubes.
5. A pressure regulator to keep the pump's working pressure at the best possible level (max 5-8 bar) between the pump and the compressed air line.
6. A cut-off switch can enable the operator to stop the pump at any given moment by cutting the air supply off between the pump and the compressed air line.
7. Switch on all switch.

WALL INSTALLED

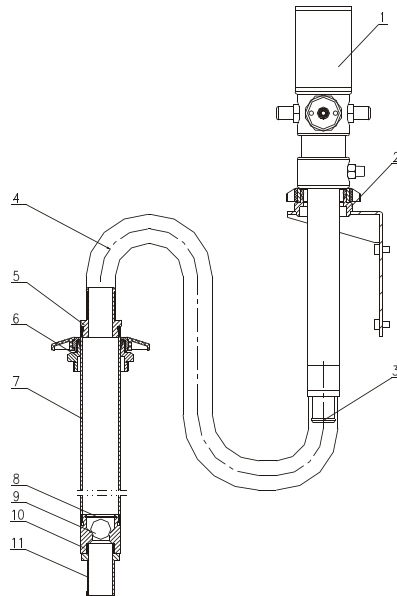

Parts List

Code	Name	Quantity
1	Oil pump	1
2	Wall bracket	1
3	Pump adapter	1
4	Flexible suction hose	1
5	Suction hose adapter	1
6	Bung adapter	1

Code	Name	Quantity
7	Rigid suction tube	1
8	Spring circlip	1
9	Ball	1
10	Valve seat	1
11	Filter	1



PROCEED AS FOLLOWS:

1. Secure the bracket to the wall using the dowels at about 1200mm height appropriate for the tank's dimensions. Make sure that the wall is solid and thick enough for the dowels. Do not interfere with hydraulic tubes or electric lines.
2. Secure the pump to the bracket 2.
3. Connect the flexible suction tube 4 to the pump using the clamp provided.
4. Connect the rigid suction 7 to the end of the flexible suction tube 4 using the elastic clamp provided.
5. Put the bung adapter 6 into the drum hole.
6. Put the rigid suction tube 7 into the pump and secure it in place.

EXTENSION TRANSFER

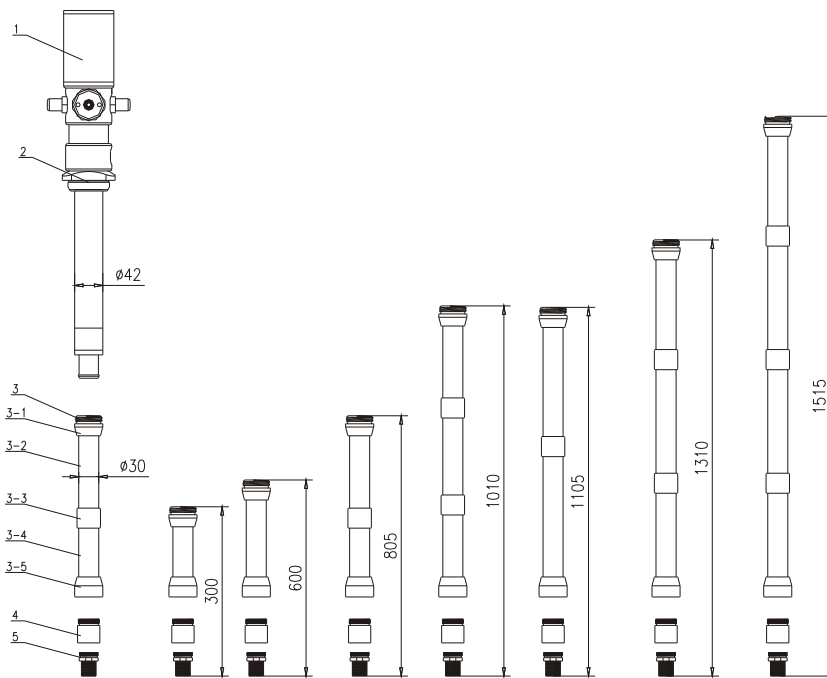

Parts List

Code	Name	Quantity
1	Oil pump	1
2	Bung adapter	1
3	Foot valve	1
4	Filter	1
5	Top connection	1
6	Extension 500mm tube	1

Code	Name	Quantity
7	Extension sleeve	1
8	Extension 200mm tube	1
9	Foot connection	1
10	Foot valve	1
11	Filter	1



PROCEED AS FOLLOWS:

1. Depending on the length of the suction tube the desired extension length.
Can be realized by using the modular extension elements(See the examples given Above)
2. Examples of possible application to pump with drum or rigid suction tube for
Obtaining personalized lengths according to needs.
3. Remove filter and foot valve from the stub pump, screw the extension tube on (W/top connection), then screw filter and foot valve on the extension tube(foot connection End)

CONNECT THE PUMP WITH OTHER ACCESSORIES:

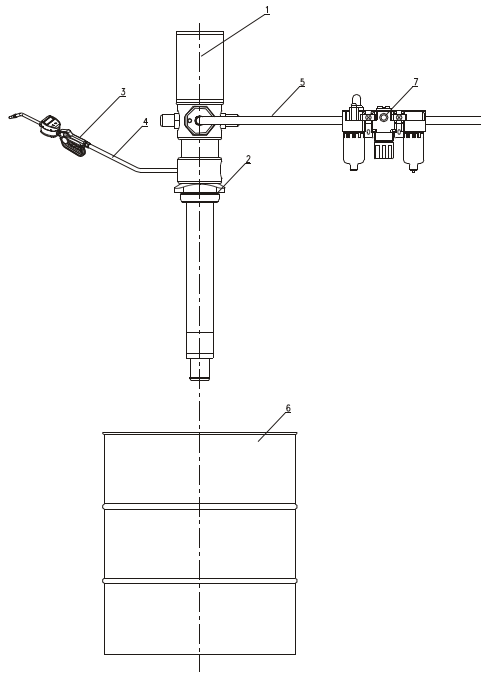

Part List

Code	Name
1	Oil pump
2	Bung adapter
3	Oil pistol
4	Hose with fitting
5	Air hose with quick coupling
6	Drum
7(7-1,7-2,7-3)	Filter, pressure regulator and lubricator



THE MANUAL OF OIL PUMP DISTRIBUTION KITS

PRESSURE RELIEF PROCEDURE

To reduce the risk of serious bodily injury, including fluid injection, splashing in the eyes or on the skin, or injury from moving parts, please always follow this procedure whenever you shut off the pump, when check or service any part of the spray/dispensing system, when install, clean or change spray tips/nozzles, and whenever you stop spraying/dispensing.

1. Shut off the air to the pump.
2. Point the outlet of grease gun to container and trigger the grease gun to relieve pressure.

IMPORTANT NOTES:

If you suspect that the spray tip/nozzle or hose is completely clogged, or that pressure has not been fully relieved after following the steps above, VERY SLOWLY loosen the retaining nut or hose end coupling and relieve pressure gradually, then loosen completely. Now clear the tip/nozzle or hose.

KITS EXPLODED VIEW

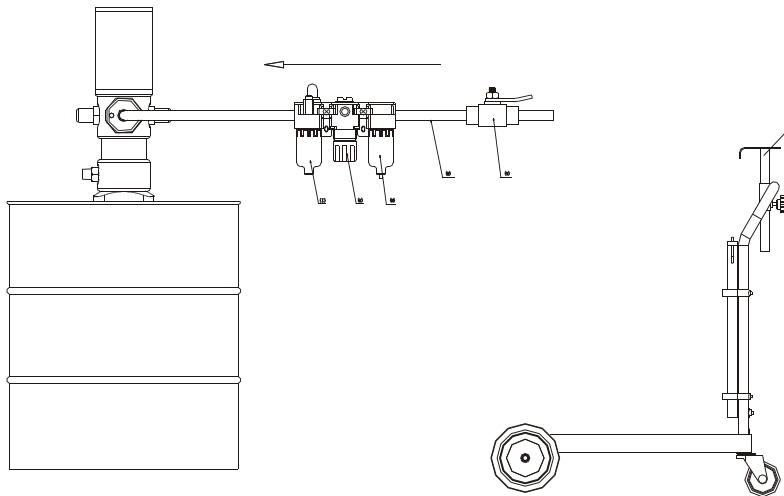

Kits List

Item No.	1700222	1700232	1700233
Drum application	30-50kgs/120lbs	180-220kgs/400lbs	180-220kbs/400lbs
3:1 Ratio pump	1701032	1701033	1701033
Digital control valve	1781801	1781801	1781801
1/2" x 13' connection hose	1763413	1763413	1763413
Drum trolley	1708001	1708002	1708003
1/2" x 50' Oil hose reel	***	***	M820154/M860154