



LUBE Lube Control Pty Ltd
Control



LEADERS IN FLUID TRANSFER SOLUTIONS

AIR-OPERATED DOUBLE DIAPHRAGM PUMP USER'S MANUAL



WARNING: Read carefully and understand all INSTRUCTIONS before operating. Failure to follow the safety rules and other basic safety precautions may result in serious personal injury. Save these instructions in a safe place and on hand so that they can be read when required.

MODEL NUMBER: DITI17151201, DITI17150601V, DITI17150600N

AIR-OPERATED DOUBLE DIAPHRAGM PUMP USER'S MANUAL

MODEL NUMBER
DITI17151201, DITI17150601V,
DITI17150600N

A. TECHNICAL INFORMATION

Model	DITI17151201	DITI17150600N	DITI17150601V
Inlet/Outlet	1"	3/4"	3/4"
Air Inlet	1/4"	1/4"	1/4"
Flow Rate	24GPM/ 90LPM	16GPM/ 60LPM	16GPM/ 60LPM
Maximum Air Inlet Pressure	115PSI/ 8BAR	115PSI/ 8BAR	115PSI/ 8BAR
Maximum Outlet Pressure	115PSI/ 8BAR	115PSI/ 8BAR	115PSI/ 8BAR
Max. Diameter Solid	1/8"	1/8"	1/8"
Pump Body	PP	Aluminum	PP
Membrane	Nitrile, Fluorin Rubber & EPDM is optional		

AIR CONSUMPTION CHART FOR MODEL: DITI17151201

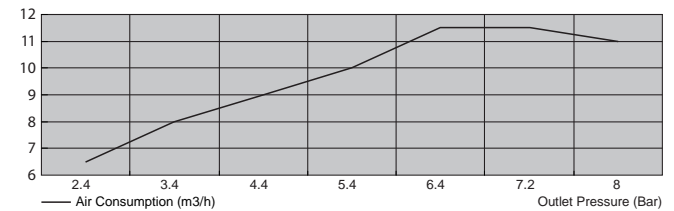

AIR CONSUMPTION CHART FOR MODEL: DITI17150600N

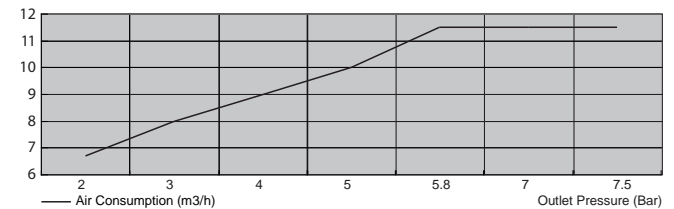

AIR CONSUMPTION CHART FOR MODEL: DITI17150601V

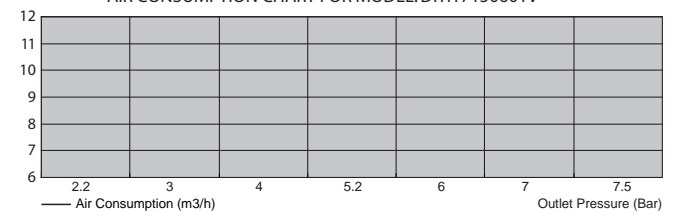



Lube Control Pty Ltd

AIR-OPERATED DOUBLE DIAPHRAGM PUMP USER'S MANUAL

MODEL NUMBER

DIT117151201, DIT117150601V,
DIT117150600N

B. OPERATING AND SAFETY PRECAUTIONS

READ, UNDERSTAND, AND FOLLOW THIS INFORMATION TO AVOID INJURY AND PROPERTY DAMAGE.



WARNING!

EXCESSIVE AIR PRESSURE. Can cause personal injury, pump damage or property damage.

- Do not exceed the maximum inlet air pressure as stated on the pump model plate.
- Be sure material hoses and other components are able to withstand fluid pressures developed by this pump. Check all hoses for damage or wear. Be certain dispensing device is clean and in proper working condition.



WARNING! STATIC SPARK. Can cause explosion resulting in severe injury or death. Ground pump and pumping system.

- Spark can ignite flammable material and vapors.
- The pumping system and object being sprayed must be grounded when it is pumping, flushing, recirculating or spraying flammable materials such as paints, solvents, lacquers etc. or used in a location where surrounding atmosphere is conducive to spontaneous combustion. Ground the dispensing valve or device, containers, hoses and any object to which material is being pumped.
- Use the pump grounding screw terminal provided. Connect a suitable ground wire to a good earth ground source.
- Secure pump, connections and all contact points to avoid vibration and generation of contact or static spark.
- Consult local building codes and electrical codes for specific grounding requirements.
- After grounding, periodically verify continuity of electrical path to ground. Test with an ohmmeter from each component (e.g., hoses, pump, clamps, container, spray gun, etc.) to ground to insure continuity. Ohmmeter should show 100 ohms or less.
- Use proper ventilation.
- Keep inflammables away from heat, open flames and sparks.
- Keep containers closed when not in use.



WARNING! Pump exhaust may contain contaminants. Can cause severe injury. Pipe exhaust away from work area and personnel.

- In the event of a diaphragm rupture material can be forced out of the air exhaust muffler.
- Pipe the exhaust to a safe remote location when pumping hazardous or inflammable materials.



WARNING! HAZARDOUS PRESSURE. Can result in serious injury or property damage. Do not service or clean pump, hoses or dispensing valve while the system is pressurized.



WARNING! EXPLOSION HAZARD. Models containing aluminum wetted parts cannot be used with III.

-Trichloroethane, Methylene Chloride or other Halogenated Hydrocarbon solvents which may react and explode.



CAUTION! Verify the chemical compatibility of the pump wetted parts and the substance being pumped, flushed or recirculated.



CAUTION! Do not use the pump for the structural support of the piping system. Be certain the system components are properly supported to prevent stress on the pump parts.



CAUTION! Prevent unnecessary damage to the pump. Do not allow pump to operate when out of material for long periods of time.

Disconnect air line from pump when system sits idle for long periods of time.

2 of 9

AIR-OPERATED DOUBLE DIAPHRAGM PUMP USER'S MANUAL

MODEL NUMBER

DIT117151201, DIT117150601V,
DIT117150600N

C. GENERAL DESCRIPTION

- The diaphragm pump offer high volume delivery even at low air pressure.
- Air-operated double diaphragm pumps utilize a pressure differential in the air chambers to alternately create suction and positive fluid pressure in the fluid chambers, ball check insure a positive flow of fluid.
- Pump cycling will begin as air pressure is applied and it will continue to pump and keep up with the demand. It will build and maintain line pressure and will stop cycling once maximum line pressure is reached (dispensing device closed) and will resume pumping as needed.

D. AIR AND LUBE REQUIREMENTS



WARNING!

EXCESSIVE AIR PRESSURE. Can cause pump damage, personal injury or property damage.

- The air delivery pipe should be big enough to ensure the air needed.
- Air pressure not exceed 115 PSI (8 BAR).
- A filter capable of filtering out particles larger than 50 microns should be used on the air supply. There is no lubrication required other than the O-ring lubricant which is applied during assembly or repair.
- If lubricated air is present, make sure that is compatible with the O-rings in the air motor section of the pump.

E. OPERATING INSTRUCTIONS

- Always flush the pump with a solvent compatible with the material being pumped if the material being pumped is subject to "setting up" when not in use for a period of time.
- Disconnect the air supply from the pump if it is to be inactive for a few hours.
- Disconnect the air supply from the pump if it is not in use.
- The material supply tubing should not be too small or restrictive. Be sure not to use hose which might collapse.
- When the diaphragm pump is used in a forced-feed (flooded inlet) situation, it is recommended that a "Check Valve" be installed at the air inlet.
- Secure the diaphragm pump legs to a suitable surface to insure against damage by vibration.

F. MAINTENANCE

- Provide a clean work surface to protect sensitive internal moving parts from contamination from dirt and foreign matter during service disassembly and reassembly.
- Keep good records of service activity and include pump in preventive maintenance program.
- Before disassembling, empty captured material in the outlet manifold by turning the pump upside down to drain material from the pump.

G. TROUBLE SHOOTING

Product discharged from exhaust outlet.

- Check for diaphragm rupture
- Check tightness of diaphragm

Air bubbles in product discharge.

- Check connections of suction plumbing
- Check O-rings between intake manifold and fluid caps
- Check tightness of diaphragm nut

Low output volume, erratic flow, or no flow.

- Check air supply
- Check for plugged outlet hose
- Check for kinked (restrictive) or collapsed inlet material hose
- Check if there is leakage for the connection. These must be air tight
- Inspect the pump for solid objects logged in the diaphragm chamber or the seat area

3 of 9



**LUBE
Control**

Lube Control Pty Ltd

**AIR-OPERATED DOUBLE DIAPHRAGM PUMP
USER'S MANUAL**

MODEL NUMBER

DIT117151201, DIT117150601V,
DIT117150600N

H. DIAGRAM & PARTS LIST

FLUID SECTION FOR MODEL: DIT117151201

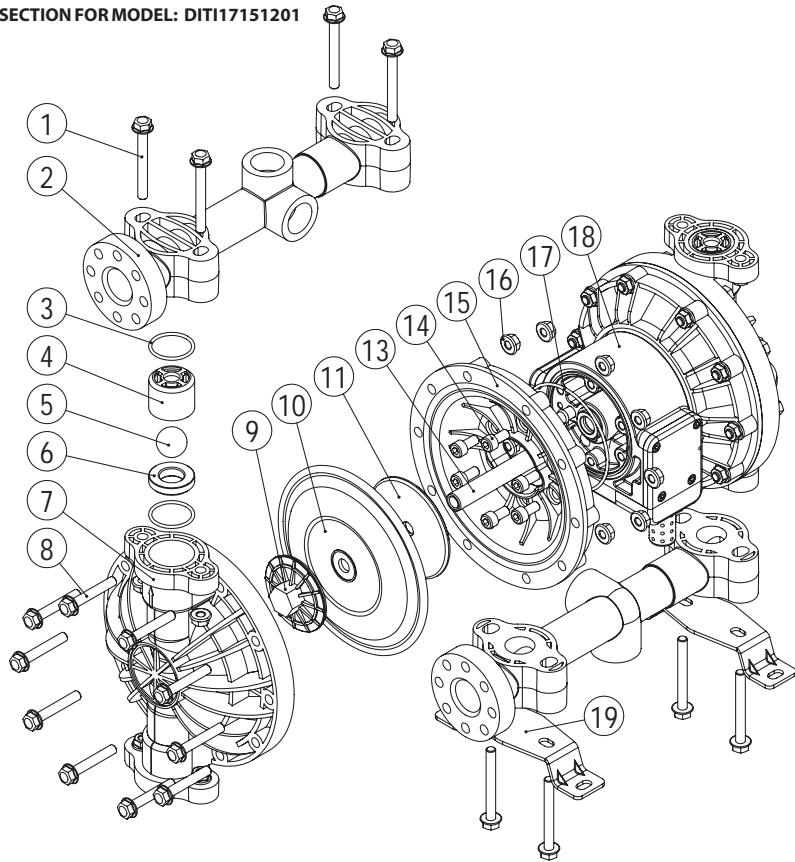

No.	Description	Qty.	No.	Description	Qty.
1	Hex-bolt M8x70	8	11	Air Chamber Plate	2
2	Discharge Manifold	2	13	Connecting Shaft	1
3	O-ring	8	14	Screw	12
4	Valve Cover	4	15	Air Chamber	2
5	Valve Ball	4	16	Screw	28
6	Valve Seat	4	17	O-ring	2
7	Liquid Chamber	2	18	Air Motor Assembly	1
8	Hex-bolt M8X50	20	19	Bracket	2
9	Liquid Chamber Plate	2			
10	Diaphragm	2			

4 of 9

**AIR-OPERATED DOUBLE DIAPHRAGM PUMP
USER'S MANUAL**

MODEL NUMBER

DIT117151201, DIT117150601V,
DIT117150600N

H. DIAGRAM & PARTS LIST

FLUID SECTION FOR MODEL: DIT117150601V

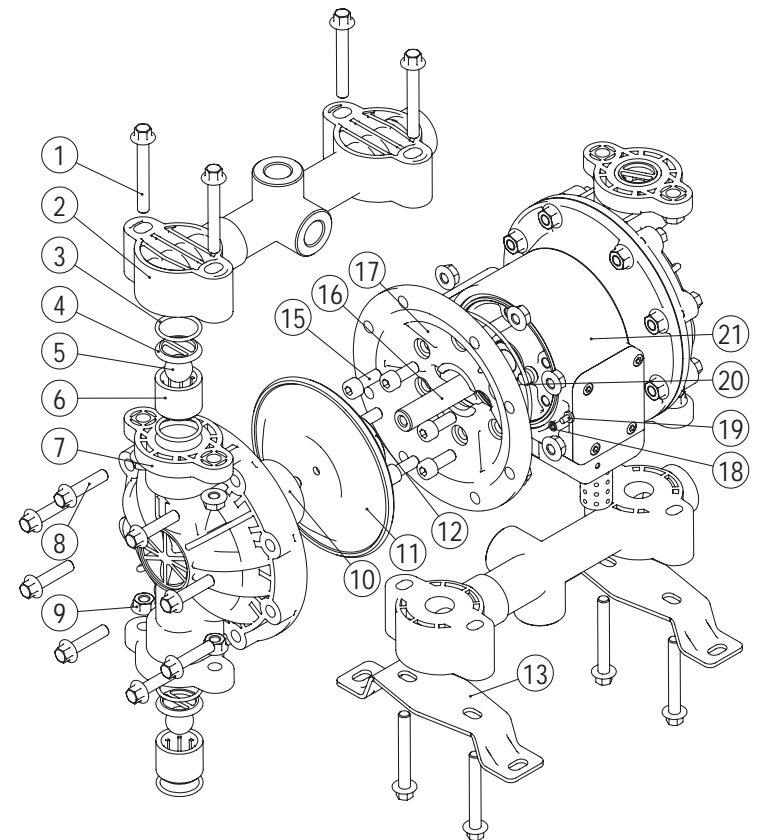

No.	Description	Qty.	No.	Description	Qty.
1	Hex-bolt M8x60	8	11	Diaphragm	2
2	Discharge Manifold	2	12	Air Chamber Plate	2
3	O-ring 28.24x2.62	8	13	Bracket	2
4	Valve Cover	4	15	Screw M8X16	12
5	Valve Ball	4	16	Connecting Shaft	1
6	Valve Seat	4	17	Air Chamber	2
7	Liquid Chamber	2	18	Washer	1
8	Hex-bolt M8X35	16	19	Screw M5X8	1
9	Nut M8	24	20	O-ring 94.92X2.62	2
10	Liquid Chamber Plate	2	21	Air Motor Assembly	1

5 of 9



**LUBE
Control**

Lube Control Pty Ltd

**AIR-OPERATED DOUBLE DIAPHRAGM PUMP
USER'S MANUAL**

MODEL NUMBER

DIT117151201, DIT117150601V,
DIT117150600N

H. DIAGRAM & PARTS LIST

FLUID SECTION FOR MODEL: DIT117150600N

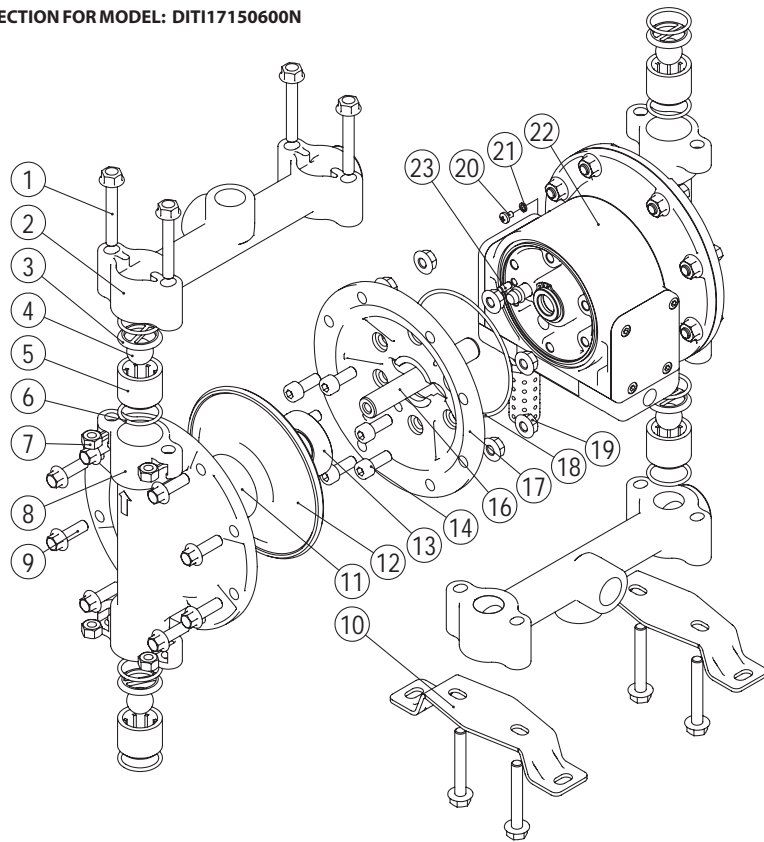

No.	Description	Qty.	No.	Description	Qty.
1	Hex-bolt M8x55	8	12	Diaphragm	2
2	Discharge Manifold	2	13	Air Chamber Plate	2
3	Valve cover	4	14	Screw M8X16	12
4	Valve Ball	4	16	Connecting Shaft	1
5	Valve Seat	4	17	Air Chamber	2
6	O-ring 28.24x2.62	8	18	O-ring 94.92X2.62	2
7	Nut M8	8	19	Hex-bolt M8	16
8	Liquid Chamber	2	20	Screw M5X8	1
9	Hex-bolt M8X25	16	21	Washer	1
10	Bracket	2	22	Air Motor Assembly	1
11	Liquid Chamber Plate	2	23	straight pin	2

6 of 9

**AIR-OPERATED DOUBLE DIAPHRAGM PUMP
USER'S MANUAL**

MODEL NUMBER

DIT117151201, DIT117150601V,
DIT117150600N

I. AIR MOTOR SECTION

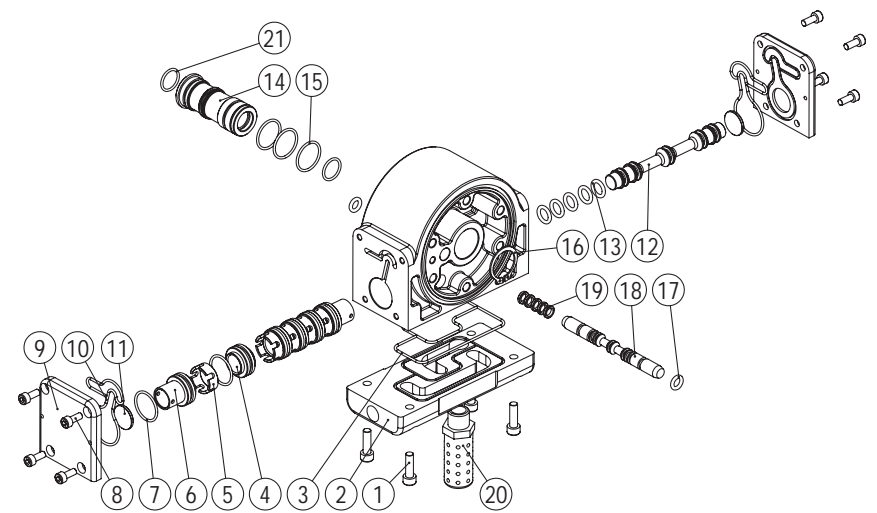

No.	Description	Qty.	No.	Description	Qty.
1	Hex-bolt M6X20	4	12	Major Valve	1
2	Press board	1	13	O-ring 9.93X2.62	5
3	Seal for press board	1	14	Sleeve	1
4	Spacer	4	15	O-ring 20.35X1.78	3
5	Spacer	5	16	Retaining Ring 25	1
6	Spacer	2	17	O-ring 7.1X2.65	2
7	O-ring 20.35X1.78	6	18	Pilot Valve	1
8	Hex bolt M5X12	8	19	O-ring 6.86X1.78	5
9	Gasket	2	20	Muffler 3/8"	1
10	Seal for gasket	2	21	O-ring	2
11	Washer	2			

7 of 9

**AIR-OPERATED DOUBLE DIAPHRAGM PUMP
USER'S MANUAL**

MODEL NUMBER

DITI17151201, DITI17150601V,
DITI17150600N

J. DIMENSIONAL DATA

