



Lube Control Pty Ltd



LEADERS IN FLUID TRANSFER SOLUTIONS

80L Oil Control Valve Instruction Manual



WARNING:

Read carefully and understand all **INSTRUCTIONS** before operating. Failure to follow the safety rules and other basic safety precautions may result in serious personal injury. Save these instructions in a safe place and on hand so that they can be read when required. Keep these instructions to assist in future servicing.

REV 09/01/17



**LUBE
Control**

Lube Control Pty Ltd



LEADERS IN FLUID TRANSFER SOLUTIONS

GENERAL SAFETY REGULATIONS



WARNING: The warnings, cautions, and instructions discussed in this instruction manual cannot cover all possible conditions or situations that could occur. It must be understood by the operator that common sense and caution are factors that cannot be built into this product, but must be supplied by the operator.

1. Keep the work area clean and dry. Damp or wet work areas can result in injury.
2. Keep children away from work area. Do not allow children to handle this product.
3. Use the right tool for the job. Do not attempt to force small equipment to do the work of larger industrial equipment. There are certain applications for which this equipment was designed. It will do the job better and more safely at the capacity for which it was intended. Do not modify this equipment, and do not use this equipment for a purpose for which it Was not intended.
4. Check for damaged parts. Before using this product, carefully check that it will operate properly and perform its intended function. Check for damaged parts and any other conditions that may affect the operation of this product. Replace damaged or worn parts immediately.
5. Do not overreach. Keep proper footing and balance at all times to prevent tripping, falling, back injury, etc.
6. DO NOT use the equipment when tired or under the influence of drugs, alcohol, or medication. A moment of inattention while operating this equipment may result in serious personal injury

TECHNICAL DETAILS

Item No.	18118001/18118002	18118003/18118004	18118005/18118006	18128001/18128002	18128003/18128004
Inlet connection	3/4"				
Fluid Range	1~80L/M (0.3~21gpm)			6-80L/M (1-21gpm)	
Pressure Range					
Temperature	5~100Bar		0.5~100Bar	5~50Bar	
Precision	≤60°C				
Viscosity	--			±0.5%	
Power source	8-5000mps				
Rigid tube	■	—	■	■ 1x3V CR2 battery	
Flexible hose	—	■	—	—	■
Automatic tip	■	■	—	■	■
Digital meter	—	—	—	■	■
Note	BSP/NPT	BSP/NPT	BSP/NPT	BSP/NPT	BSP/NPT

⚠ IMPORTANT! This manual contains important warnings and information.
READ AND KEEP IT FOR REFERENCE.

SAFETY PRECAUTIONS
GENERAL SAFETY RULES

⚠ WARNING
Read and understand all instructions.

INSTALLATION
Precaution Before Installation:

1. Check if there is any data shown on the display.
 2. Check if the trigger can work normally.
 3. Check if the oil inlet can rotate well.
 4. During assembly, it's required to apply the Teflon tape for the connecting part.
1. Control valve is 3/4" oil inlet, when connecting with hose fitting, please remember to apply the Teflon for better seal

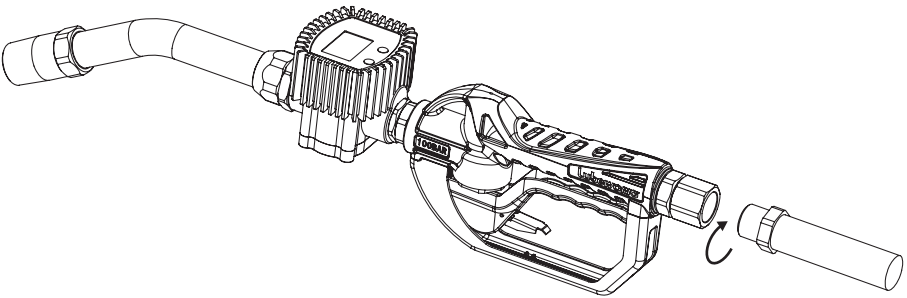

E1

 TECHNICAL
DETAILS

 SAFETY
PRECAUTIONS

INSTALLATION

OPERATION

MAINTENANCE

 EXPLODED AND
PARTS LIST

2. Usage instruction:

- (1) Start:
Turn on the trigger to make the oil transmission.

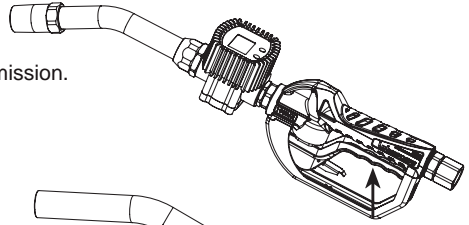

- (2) Keep the status:
Push the lock ahead, then the transmission can be kept when the trigger is released.

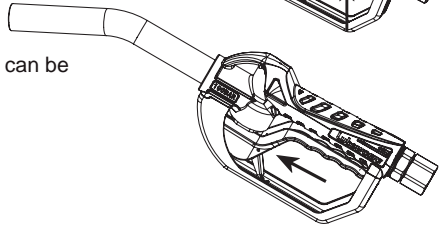

- (3) Finish:
a. If the lock is not used, release your hand, the trigger will turn off and finish the transmission.

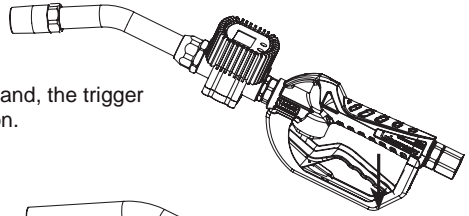

- b. If the lock is used, please turn on the trigger once again, the lock will stop working. Then turn off the trigger, release your hand, the transmission will be finished.

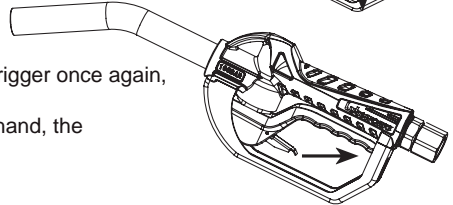

Notes When Using:

Cautions:

1. For working condition, please refer to the specification parameter list. Temperature: -10°C~60°C
2. Medium: Lubricant Oil,.

Maintenance

If any problem, please contact your local service centre.

OPERATION

FUNCTION BUTTON INTRODUCTION

- ① LCD display
- ② "MOVE" button
- ③ "RESET" button

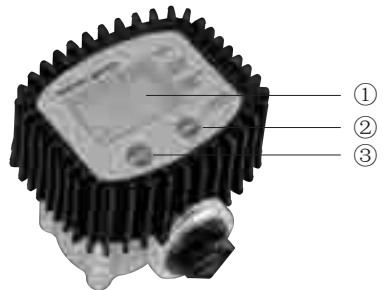

E2

LCD DISPLAY

KEY

- ① Partial register (5 figures with moving comma from 0.1 to 99999)
Indicating the volume dispensed since the reset button was last pressed.
- ② Indication of battery charge
- ③ Indication of calibration mode
- ④ Indication of resetting present total to Zero
- ⑤ Total register
- ⑥ Indication of flow rate mode
- ⑦ Indication of unit of measurement of partial: L= Litres
GAL = Gallons
PT = Pints
QT = Quarts

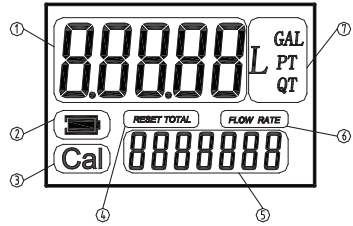

USER BUTTONS

The turbine digital meter features two buttons (MOVE and RESET) which individually perform two main functions and together, other secondary functions.

The main functions performed are:

For the reset key, resetting the partial Register and reset table total (reset total)

For the move key, entering instrument calibration mode.

Used together, the two keys permit entering configuration mode,

BATTERY REPLACEMENT

When replacing the battery, please open the cover, remove the plug and replace the battery.

DAILY USE

BUTTON USAGE, CALIBRATION AND MEASUREMENT UNIT CHANGE

- **Reset the present total (See Fig. 4)**
 - 1) When the meter is on standby, press the RESET key.
 - 2) The display shows all the segments.
 - 3) The meter resets the present total already.



Fig. 4

- **Show current correction factor and general total (See Fig. 5)**

Press MOVE and RESET together and hold for two seconds.

Value "1.4000" is the correction factor which can be reset;

"1234567" is the general total which cannot be reset.



Fig. 5



• **Measurement unit change (See Fig. 6)**

Press MOVE and RESET together and hold for five seconds.

Zone 7 on the display is the current unit. Press RESET to chose a different measurement unit and then press MOVE to confirm.

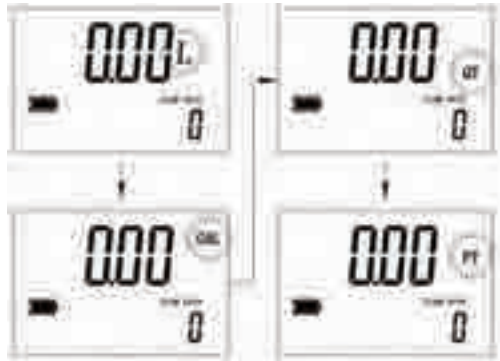

Fig. 6

• **Reset The Resettable Total (See Fig. 7)**

When the meter is on standby, press the RESET key for 2 seconds to reset the present total first.



Fig. 7

E4



**LUBE
Control**

Lube Control Pty Ltd

PROCEDURE FOR ENTER THE CORRECTION FACTOR DIRECTLY

Carefully follow the procedure indicated below.

FORMULA

Proper correction factor = current correction factor × (actual value / display value)





Example:

Actual value 20.75

Display value 18.96

Current correction factor 1.000

Proper correction factor 1.000 × (20.75 / 18.96) = 1.000 × 1.094 = 1.094

1	Wait for the meter to go to standby.	
2	Reset the resettable total.	
3	Press the MOVE key. Keep it pressed until similar with the image showed (the digit flash in ① zone), it means the meter is in correction factor modification mode.	
4	Press the RESET key to choose the right digit from 0 to 9. Press the MOVE key to start the next digit. So the digit of correction factor can be changed one by one.	
5	Make sure the correction factor is right, press the MOVE key. Keep it pressed until quit calibration mode, the factor is saved. The meter goes to standby again.	

TECHNICAL
DETAILS

SAFETY
PRECAUTIONS

INSTALLATION

OPERATION

MAINTENANCE

EXPLODED AND
PARTS LIST

E5



**LUBE
Control**

Lube Control Pty Ltd

TECHNICAL
DETAILS

SAFETY
PRECAUTIONS







INSTALLATION

OPERATION

MAINTENANCE

EXPLODED AND
PARTS LIST

**MODIFY THE CORRECTION FACTOR IN FIELD
PLEASE CAREFULLY FOLLOW THE PROCEDURE INDICATED BELOW.**

1	Wait for the meter to go to standby.	
2	Reset the resettable total.	
3	Start dispensing into a measuring glass. Stop dispensing when over 5 Litres of volume is reached, read out the actual value. The volume that is displayed on the LCD is the Display Value, not the Actual Value which may be slightly higher. For example, in the figure on the right, the Display Value is 18.96 while the Actual Value is 20.75.	
4	Press the MOVE key. Keep it pressed until showed as the right fig., the digit flash in ① zone, Press the RESET key to choose the right digit from 0 to 9. Press the MOVE key to go the the next digit so that the Actual Value can be input.	 
5	Make sure the correction factor is right and then press the MOVE key. Keep it pressed until calibration is finished and the factor is save. The meter will then return to standby.	

E6

MAINTENANCE

Battery replacement

- When the battery signal is flashing on the LCD (see Fig. 8), it means the meter is in low battery. In this condition, the meter continues to work correctly, but the flashing icon warns the user that it is advisable to change the battery.



Fig. 8

- Remove the Rubber protection, screw off the screw on the battery cover, then open the battery box to change the battery. After that, install the battery cover, tighten the screw, fix on the rubber protection to finish the battery change.

- Battery type: 1×CR2(3V)



OIL CONTROL VALVE EXPLODED DRAWING

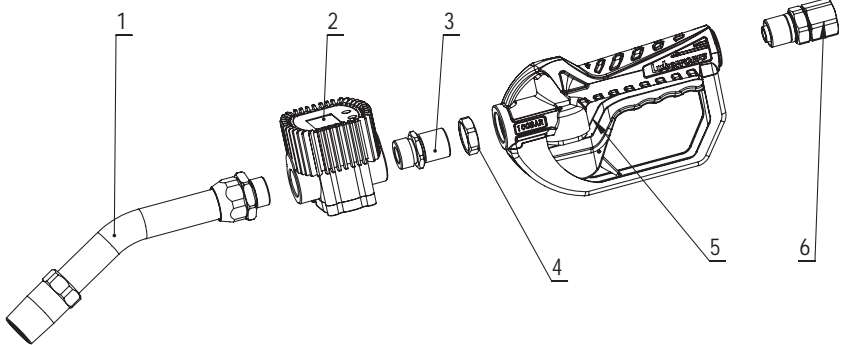

Oil Control Valve Part List

Part No.	Description	Q'ty	Part No.	Description	Q'ty
1	Spout	1	4□	Hexagon Nut	1
2□	Digital Meter	1	5	Handle Body	1
3□	3/4" swivel	1	6	Swivel Fitting	1

Note: □ Digital oil control valve part

E7

TECHNICAL
DETAILS

SAFETY
PRECAUTIONS

INSTALLATION

OPERATION

MAINTENANCE

EXPLODED AND
PARTS LIST



TECHNICAL
DETAILS

RIGID SPOUT EXPLODED DRAWING & PART LIST

SAFETY
PRECAUTIONS

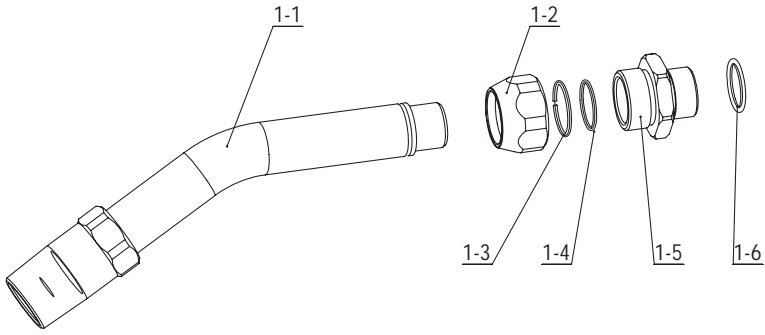

Part No.	Description	Q'ty	Part No.	Description	Q'ty
1-1	Spout	1	1-4	O Ring	1
1-2	Nut	1	1-5	Adapter	1
1-3	Spring Clip	1	1-6	O Ring	1

INSTALLATION

VALVE BODY EXPLODED DRAWING & PART LIST

OPERATION

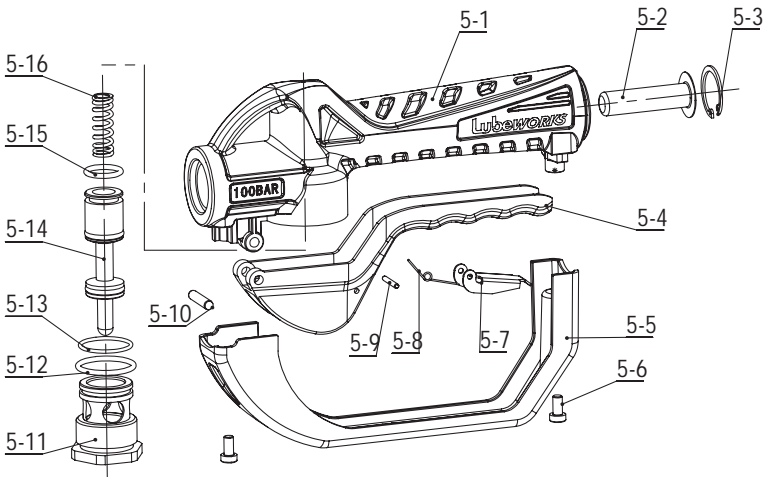

MAINTENANCE

Part No.	Description	Q'ty	Part No.	Description	Q'ty
5-1	Handle Body	1	5-9	Pin	1
5-2	Filter	1	5-10	Pin	1
5-3	Retainer	1	5-11	Piston Sleeve	1
5-4	Trigger	1	5-12	O Ring	1
5-5	Grip	1	5-13	O Ring	1
5-6	Screw	2	5-14	Slip Pole	1
5-7	Trigger Lock	1	5-15	O Ring	3
5-8	Clip	1	5-16	Spring	1

EXPLODED AND
PARTS LIST

E8



EXPLODED AND PARTS LIST

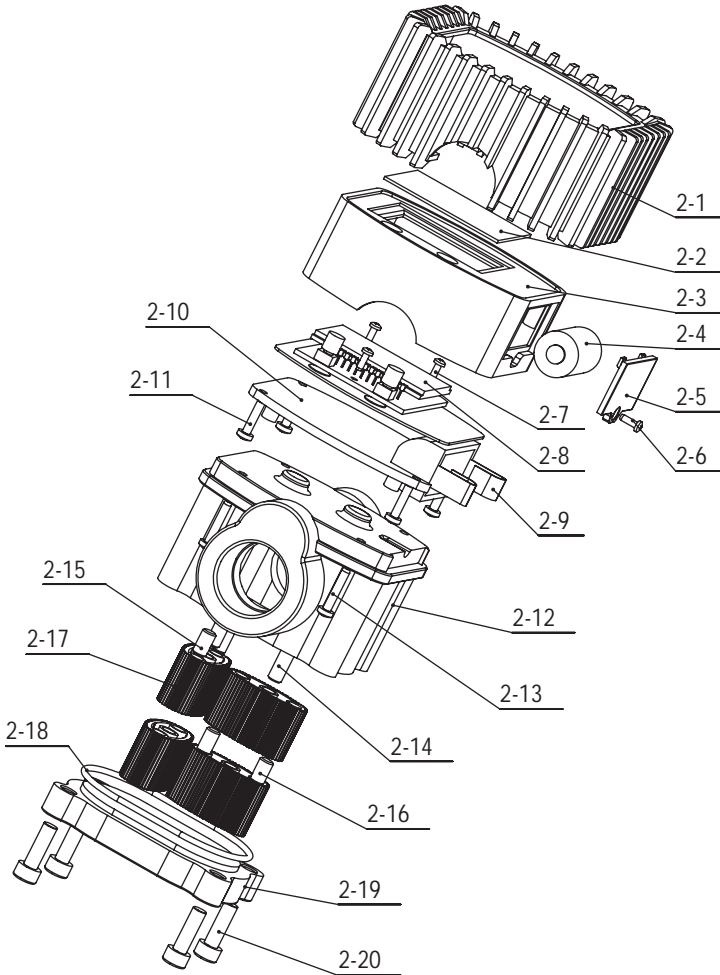

Part No.	Description	Q'ty	Part No.	Description	Q'ty
2-1	Rubber Protection	1	2-11	Self tapping screw	4
2-2	Protection board for LCD Display	1	2-12	Meter Body	1
2-3	Meter Cover	1	2-13	Self tapping screw	4
2-4	Battery	1	2-14	Shaft	2
2-5	Battery Cover	1	2-15	Magnet	2
2-6	Self tapping screw	1	2-16	Pin	2
2-7	Self tapping screw	3	2-17	Oval Gear	4
2-8	Electrical board	1	2-18	O ring	1
2-9	Spring slice for battery	2	2-19	Bottom plate	1
2-10	Fix board	1	2-20	Hexagon Screw	4