

Exploded drawing and Parts list

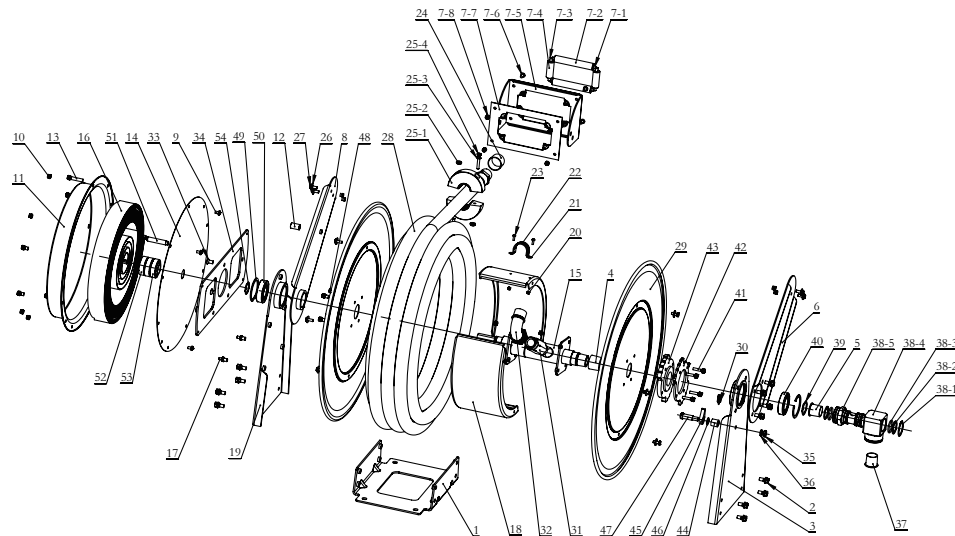

| Part No. | Description | Q'ty | Part No. | Description | Q'ty | Part No. | Description | Q'ty |
|----------|------------------------|------|----------|---------------------------|------|----------|---------------------|------|
| 1 | Base Assembly | 1 | 17 | Bolt | 2 | 37 | Protection Cover | 1 |
| 2 | Screw | 12 | 18 | Drum Support Plate | 2 | 38-1 | Retainer | 1 |
| 3 | Bracket 2 Assembly | 1 | 19 | Bracket 1 Assembly | 1 | 38-2 | Retainer | 2 |
| 4 | Protection Cover | 1 | 20 | Nut | 2 | 38-3 | O-Ring | 2 |
| 5 | Protection Cover | 1 | 21 | Clamp | 1 | 38-4 | Swivel Body | 1 |
| 6 | Support Plate | 1 | 22 | Clamp Cover | 1 | 38-5 | Swivel Spool | 1 |
| 7-1 | Roller Axle | 2 | 23 | Screw | 2 | 39 | Retainer | 1 |
| 7-2 | Roller | 2 | 24 | Protection Cover | 1 | 40 | Bearing | 1 |
| 7-3 | Roller Axle | 2 | 25-1 | Bumper Block | 2 | 41 | Screw | 4 |
| 7-4 | Roller | 2 | 25-2 | Nut | 2 | 42 | The Ratchet Plate | 1 |
| 7-5 | Guide Support Plate | 1 | 25-3 | Washer | 2 | 43 | The Ratchet Plate 2 | 1 |
| 7-6 | Screw | 4 | 25-4 | Bolt | 2 | 44 | Washer | 1 |
| 7-7 | Guide Sub-plate | 1 | 26 | washer | 12 | 45 | Ratchet Paw | 1 |
| 7-8 | Nut | 4 | 27 | Bolt | 12 | 46 | Washer | 2 |
| 8 | Support Plate Assembly | 1 | 28 | Hose Assembly | 1 | 47 | Bolt | 1 |
| 9 | Screw | 3 | 29 | Drum | 2 | 48 | Screw | 8 |
| 10 | Nut | 17 | 30 | Ratchet Spring | 1 | 49 | Retainer | 2 |
| 11 | Spring Drum | 1 | 31 | Fitting | 1 | 50 | Bearing | 1 |
| 12 | Hub Bearing | 1 | 32 | Angle fitting assembly | 1 | 51 | The spring pin | 1 |
| 13 | Screw | 1 | 33 | Screw | 3 | 52 | Spring Core | 1 |
| 14 | Spring Drum Cover | 1 | 34 | Spring drum Support Plate | 1 | 53 | Spring Core | 2 |
| 15 | Main shaft Assembly | 1 | 35 | Nut | 1 | 54 | Retainer | 1 |
| 16 | Spring | 1 | 36 | Washer | 1 | | | |

P4



Industrial Hose Reel 2818 Series Instruction Manual

WARNING:
Read carefully and understand all INSTRUCTIONS before operating. Failure to follow the safety rules and other basic safety precautions may result in serious personal injury. Save these instructions in a safe place and on hand so that they can be read when required.



Technical Details

| Item No. | Max Pressure (psi/ bar) | Hose Working Temperature (°C/ °F) | Hose Capacity | | | |
|-------------|-------------------------|-----------------------------------|---------------|---------------|--------------|---------|
| | | | Material | I.D.(inch/mm) | Length(ft/m) | Threads |
| 28187158-14 | 300/20 | -20 ~ +60oC [-4 ~ +140oF] | Rubber | 1" /25.4 | 50/15 | NPT |
| 28187158-24 | | | | | | BSPT |
| 28187206-14 | | | | 3/4" /19 | 65/20 | NPT |
| 28187206-24 | | | | | | BSPT |
| 28187304-14 | 1000/69 | | SAE100R1AT | 1/2" /12.7 | 30/100/30 | NPT |
| 28187304-24 | | | | | | BSPT |
| 28188158-15 | 1250/86 | -40 ~ +100oC [-40 ~ +210oF] | | 1" /25.4 | 50/15 | NPT |
| 28188158-25 | | | | | | BSPT |
| 28188206-15 | | | | 3/4" /19 | 65/20 | NPT |
| 28188206-25 | 2000/138 | | | | | BSPT |
| 28188304-15 | | | | 1/2" /12.7 | 100/30 | NPT |
| 28188304-25 | | | | | | BSPT |

Product Dimension drawing

WARNING:
Read carefully and understand all INSTRUCTIONS before operating. Failure to follow the safety rules and other basic safety precautions may result in serious personal injury. Save these instructions in a safe place and on hand so that they can be read when required. Keep these instructions to assist in future servicing.

The warnings, cautions, and instructions discussed in this instruction manual cannot cover all possible conditions or situations that could occur. It must be understood by the operator that common sense and caution are factors which cannot be built into this product, but must be supplied by the operator.

Exposure of skin directly to pressurized air, or fluids could result in severe bodily injury.

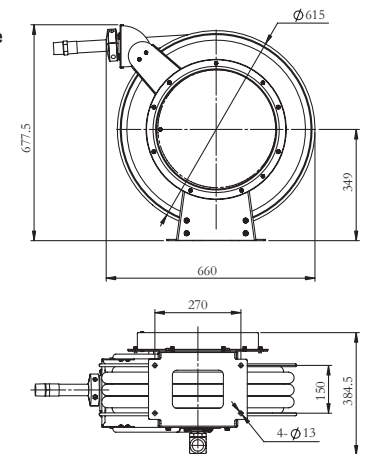

P1



Hose Reel Safety Precautions

- Use proper eye protection when assembling and using the hose reel
- Keep children away from the work area
- Personal injury and/or equipment damage may result if proper safety precautions are not observed.
- Ensure that reel is properly installed before connecting input and output hoses.
- Bleed fluid/gas pressure from system before servicing reel.
- Before connecting reel to supply line ensure that pressure does not exceed maximum working pressure rating of reel.
- Remember that even low pressure is very dangerous and can cause personal injury or death.
- If a leak occurs in the hose or reel, remove system pressure immediately.
- Make sure that the reel, hose and equipment being service are properly grounded.
- If reel ceases to unwind or rewind, remove system pressure immediately.
- Do not pull or jerk on hose.

Installation

- Prior to mounting the hose reel, ensure that the supply line pressure dose not exceed the maximum working pressure of the hose reel.
- Unpack and inspect reel for damage. Turn by hand to check for smooth operation. Check for completeness.
- For wall mounting: Install reel at most 1.5meter above the floor.
- You will need to purchase appropriate hardware for mounting your new reel.
- The reel base has four 10.5mm drilled holes for mounting on a suitable flat surface.
- Using the four holes in the base, mount the reel in the desired location. Be sure to use appropriate hardware and tighten securely.

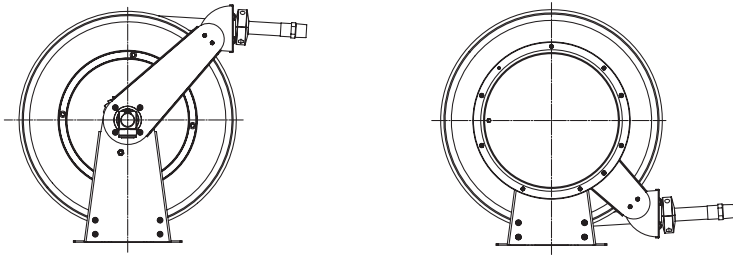

- Apply Teflon tape or pipe sealant to supply line threads, attach to reel inlet and tighten it. The other end of incoming line can now be connected to desired supply source.
- Apply Teflon tape or pipe sealant to outlet fitting on reel hose, then attach to desired tool, or nozzle. Check connection for leakage, also check hose reel for correct operation. See Operation section.
- If hose stopper adjustment is required, pull hose from reel and allow to latch at desired length. Loosen stopper bolts, and slide stopper to a position close to the hose guide. Tighten stopper bolts and unlatch the reel.

Operation

- Check reel for correct operation by slowly pulling out hose. A "click" noise will be heard every half revolution of the drum.
- To latch the reel, pull out the hose and allow it to retract after hearing the first second or third "click".
- To unlatch, slowly pull out the hose until the "click" noise stops, then let cable retract until the cable stopper rests against the cable guide.
- If necessary, adjust spring tension on reel by adding or removing wraps of hose from spool, one wraps at a time until desired tension is obtained. Add wraps to increase tension Remove wraps to decrease tension.

P2

Maintenance

- Make sure the hose is in proper working order.
- Clean the hose with a cloth dipped in warm water to remove dirt or deposits and ensure correct rewinding.
- Do not use detergents or solvents which could prove incompatible with cable-winder materials.
- Dismantling of the unit by unskilled personal could prove hazardous; the risk involved mainly concern the preloaded springs.

Limited Warranty

1. The manufacturer warrants this hose reel against defects in material and craftsmanship, for a period of 12 months from date of purchase.
2. Hose, if supplied with reel, O-rings, plastic rollers and rubber stopper are deemed to be normal wear items; not warranted.
3. Manufacturer's liability is limited to replacement or repair of defective material within the warranty period, when returned freight prepaid to the distributor or their designated service depot.
4. The warranty does not cover damage caused by accident, misuse or faulty installation.
5. The reel must be installed and maintained in compliance with the instructions.

WARNING

Your risk from these exposures varies, depending on how often you do this type of work. To reduce your exposure to these chemicals: work in a well ventilated area, and work with approved safety equipment, such as those dust masks that are specially designed to filter out microscopic particles.

P3



Hose Reel Safety Precautions

- Use proper eye protection when assembling and using the hose reel
- Keep children away from the work area
- Personal injury and/or equipment damage may result if proper safety precautions are not observed.
- Ensure that reel is properly installed before connecting input and output hoses.
- Bleed fluid/gas pressure from system before servicing reel.
- Before connecting reel to supply line ensure that pressure does not exceed maximum working pressure rating of reel.
- Remember that even low pressure is very dangerous and can cause personal injury or death.
- If a leak occurs in the hose or reel, remove system pressure immediately.
- Make sure that the reel, hose and equipment being service are properly grounded.
- If reel ceases to unwind or rewind, remove system pressure immediately.
- Do not pull or jerk on hose.

Installation

- Prior to mounting the hose reel, ensure that the supply line pressure dose not exceed the maximum working pressure of the hose reel.
- Unpack and inspect reel for damage. Turn by hand to check for smooth operation. Check for completeness.
- For wall mounting: Install reel at most 1.5meter above the floor.
- You will need to purchase appropriate hardware for mounting your new reel.
- The reel base has four 10.5mm drilled holes for mounting on a suitable flat surface.
- Using the four holes in the base, mount the reel in the desired location. Be sure to use appropriate hardware and tighten securely.

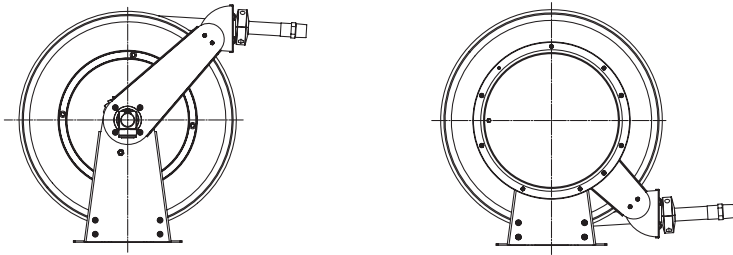

- Apply Teflon tape or pipe sealant to supply line threads, attach to reel inlet and tighten it. The other end of incoming line can now be connected to desired supply source.
- Apply Teflon tape or pipe sealant to outlet fitting on reel hose, then attach to desired tool, or nozzle. Check connection for leakage, also check hose reel for correct operation. See Operation section.
- If hose stopper adjustment is required, pull hose from reel and allow to latch at desired length. Loosen stopper bolts, and slide stopper to a position close to the hose guide. Tighten stopper bolts and unlatch the reel.

Operation

- Check reel for correct operation by slowly pulling out hose. A "click" noise will be heard every half revolution of the drum.
- To latch the reel, pull out the hose and allow it to retract after hearing the first second or third "click".
- To unlatch, slowly pull out the hose until the "click" noise stops, then let cable retract until the cable stopper rests against the cable guide.
- If necessary, adjust spring tension on reel by adding or removing wraps of hose from spool, one wraps at a time until desired tension is obtained. Add wraps to increase tension Remove wraps to decrease tension.

P2

Maintenance

- Make sure the hose is in proper working order.
- Clean the hose with a cloth dipped in warm water to remove dirt or deposits and ensure correct rewinding.
- Do not use detergents or solvents which could prove incompatible with cable-winder materials.
- Dismantling of the unit by unskilled personal could prove hazardous; the risk involved mainly concern the preloaded springs.

Limited Warranty

1. The manufacturer warrants this hose reel against defects in material and craftsmanship, for a period of 12 months from date of purchase.
2. Hose, if supplied with reel, O-rings, plastic rollers and rubber stopper are deemed to be normal wear items; not warranted.
3. Manufacturer's liability is limited to replacement or repair of defective material within the warranty period, when returned freight prepaid to the distributor or their designated service depot.
4. The warranty does not cover damage caused by accident, misuse or faulty installation.
5. The reel must be installed and maintained in compliance with the instructions.

WARNING

Your risk from these exposures varies, depending on how often you do this type of work. To reduce your exposure to these chemicals: work in a well ventilated area, and work with approved safety equipment, such as those dust masks that are specially designed to filter out microscopic particles.

P3

Exploded drawing and Parts list

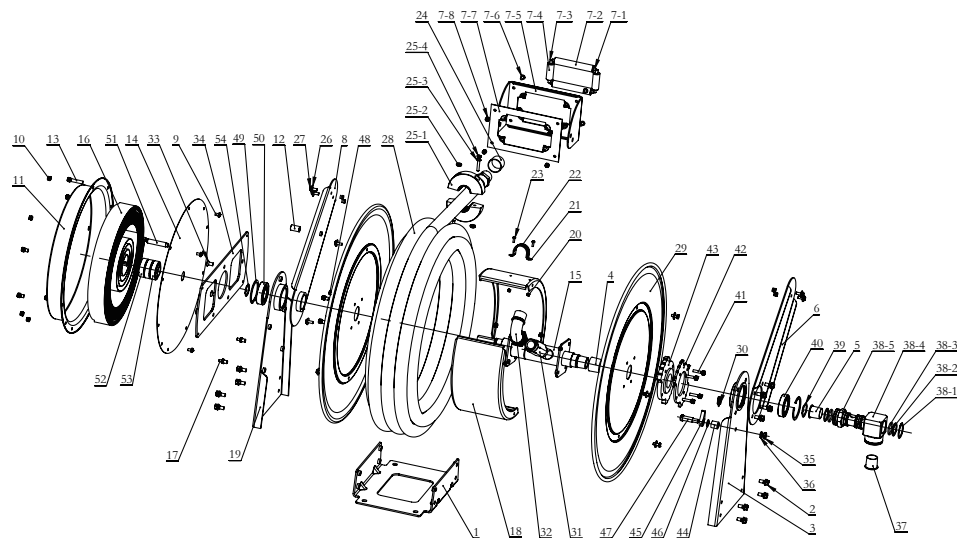

| Part No. | Description | Q'ty | Part No. | Description | Q'ty | Part No. | Description | Q'ty |
|----------|------------------------|------|----------|---------------------------|------|----------|---------------------|------|
| 1 | Base Assembly | 1 | 17 | Bolt | 2 | 37 | Protection Cover | 1 |
| 2 | Screw | 12 | 18 | Drum Support Plate | 2 | 38-1 | Retainer | 1 |
| 3 | Bracket 2 Assembly | 1 | 19 | Bracket 1 Assembly | 1 | 38-2 | Retainer | 2 |
| 4 | Protection Cover | 1 | 20 | Nut | 2 | 38-3 | O-Ring | 2 |
| 5 | Protection Cover | 1 | 21 | Clamp | 1 | 38-4 | Swivel Body | 1 |
| 6 | Support Plate | 1 | 22 | Clamp Cover | 1 | 38-5 | Swivel Spool | 1 |
| 7-1 | Roller Axle | 2 | 23 | Screw | 2 | 39 | Retainer | 1 |
| 7-2 | Roller | 2 | 24 | Protection Cover | 1 | 40 | Bearing | 1 |
| 7-3 | Roller Axle | 2 | 25-1 | Bumper Block | 2 | 41 | Screw | 4 |
| 7-4 | Roller | 2 | 25-2 | Nut | 2 | 42 | The Ratchet Plate | 1 |
| 7-5 | Guide Support Plate | 1 | 25-3 | Washer | 2 | 43 | The Ratchet Plate 2 | 1 |
| 7-6 | Screw | 4 | 25-4 | Bolt | 2 | 44 | Washer | 1 |
| 7-7 | Guide Sub-plate | 1 | 26 | washer | 12 | 45 | Ratchet Paw | 1 |
| 7-8 | Nut | 4 | 27 | Bolt | 12 | 46 | Washer | 2 |
| 8 | Support Plate Assembly | 1 | 28 | Hose Assembly | 1 | 47 | Bolt | 1 |
| 9 | Screw | 3 | 29 | Drum | 2 | 48 | Screw | 8 |
| 10 | Nut | 17 | 30 | Ratchet Spring | 1 | 49 | Retainer | 2 |
| 11 | Spring Drum | 1 | 31 | Fitting | 1 | 50 | Bearing | 1 |
| 12 | Hub Bearing | 1 | 32 | Angle fitting assembly | 1 | 51 | The spring pin | 1 |
| 13 | Screw | 1 | 33 | Screw | 3 | 52 | Spring Core | 1 |
| 14 | Spring Drum Cover | 1 | 34 | Spring drum Support Plate | 1 | 53 | Spring Core | 2 |
| 15 | Main shaft Assembly | 1 | 35 | Nut | 1 | 54 | Retainer | 1 |
| 16 | Spring | 1 | 36 | Washer | 1 | | | |

P4

Industrial Hose Reel 2818 Series Instruction Manual

WARNING:
Read carefully and understand all INSTRUCTIONS before operating. Failure to follow the safety rules and other basic safety precautions may result in serious personal injury. Save these instructions in a safe place and on hand so that they can be read when required.



Technical Details

| Item No. | Max Pressure (psi/ bar) | Hose Working Temperature (°C/ °F) | Hose Capacity | | | |
|-------------|-------------------------|-----------------------------------|---------------|---------------|---------------|---------|
| | | | Material | I.D.(inch/mm) | Length(ft./m) | Threads |
| 28187158-14 | 300/20 | -20 ~ +60oC [-4 ~ +140oF] | Rubber | 1" /25.4 | 50/15 | NPT |
| 28187158-24 | | | | | | BSPT |
| 28187206-14 | | | | 3/4" /19 | 65/20 | NPT |
| 28187206-24 | | | | | | BSPT |
| 28187304-14 | 1000/69 | -40 ~ +100oC | SAE100R1AT | 1/2" /12.7 | 30/100/30 | NPT |
| 28187304-24 | | | | | | BSPT |
| 28188158-15 | | | | | | NPT |
| 28188158-25 | 1250/86 | -40 ~ +210oF | SAE100R1AT | 1" /25.4 | 50/15 | NPT |
| 28188206-15 | | | | | | BSPT |
| 28188206-25 | | | | 3/4" /19 | 65/20 | NPT |
| 28188304-15 | 2000/138 | | SAE100R1AT | 1/2" /12.7 | 100/30 | NPT |
| 28188304-25 | | | | | | BSPT |

Product Dimension drawing

WARNING:
Read carefully and understand all INSTRUCTIONS before operating. Failure to follow the safety rules and other basic safety precautions may result in serious personal injury. Save these instructions in a safe place and on hand so that they can be read when required. Keep these instructions to assist in future servicing.

The warnings, cautions, and instructions discussed in this instruction manual cannot cover all possible conditions or situations that could occur. It must be understood by the operator that common sense and caution are factors which cannot be built into this product, but must be supplied by the operator.

Exposure of skin directly to pressurized air, or fluids could result in severe bodily injury.

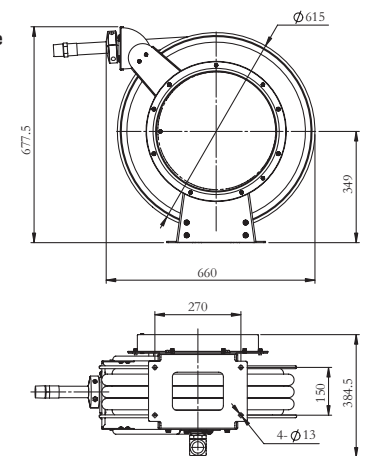

P1