

Aluminium Air Operated Diaphragm Pump DQBY40AAB / DQBY50AAB

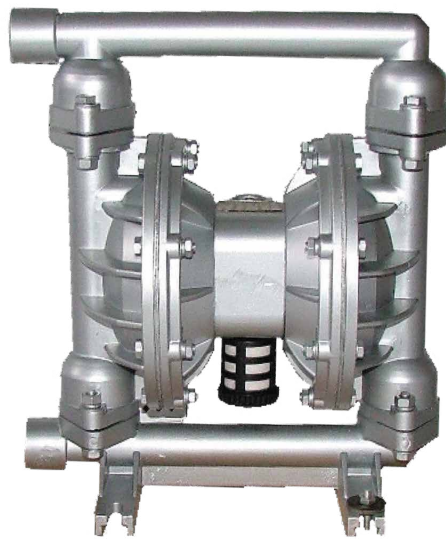

ESTABLISHMENT METHOD OF PUMP MODEL

The pump model is composed of four units and is established according to the following sequence

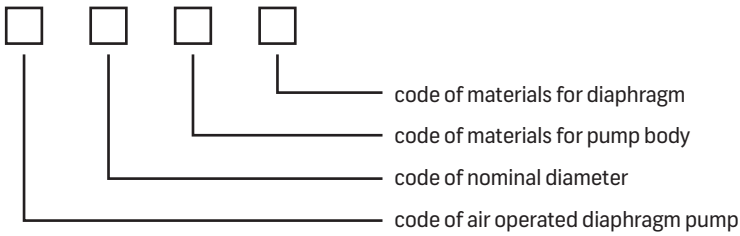

code of air operated diaphragm pump: QBY

code of nominal diameter: 10(3/8)", 15 (1/2)", 25(1)", 40 (1 1/2)", 50 (2)", 180 (3)", 100(4)"

CODE OF MATERIALS FOR PUMP BODY

Material of pump body	Code	Material of pump body	Code
Aluminium alloy	L	Stainless steel	B
Cast iron	Z	Rubber lining	ZCJ
Engineering plastic	S	Fluorine lined	CF

CODE OF MATERIALS FOR DIAPHRAGM

Material of pump body	Code	Material of pump body	Code
Buna-N	NBR	Neoprene	CR
Viton	F	Teflon	F46
Ethylene-propylene rubber	EPDM	Synthetic plastic	PP

NOTE

In order to select suitable material and design of diaphragm pump, process conditions like applied environment, temperature, medium, flow rate, pump head, pressure, pump body material, diaphragm material are required. Please be kindly noted that our diaphragm pump has two constructions in inlet and outlet, one is in the side, the other is in the center of the body. Please specify it when placing orders.

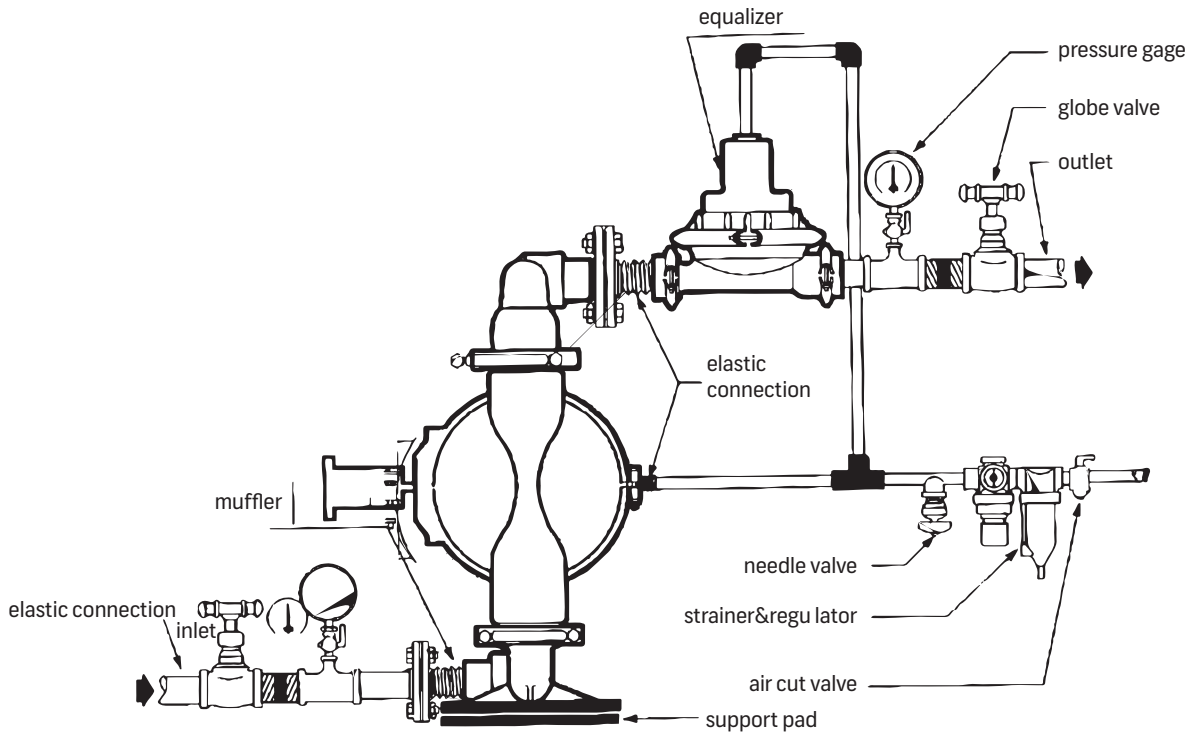

PUMP SYSTEM DRAWING

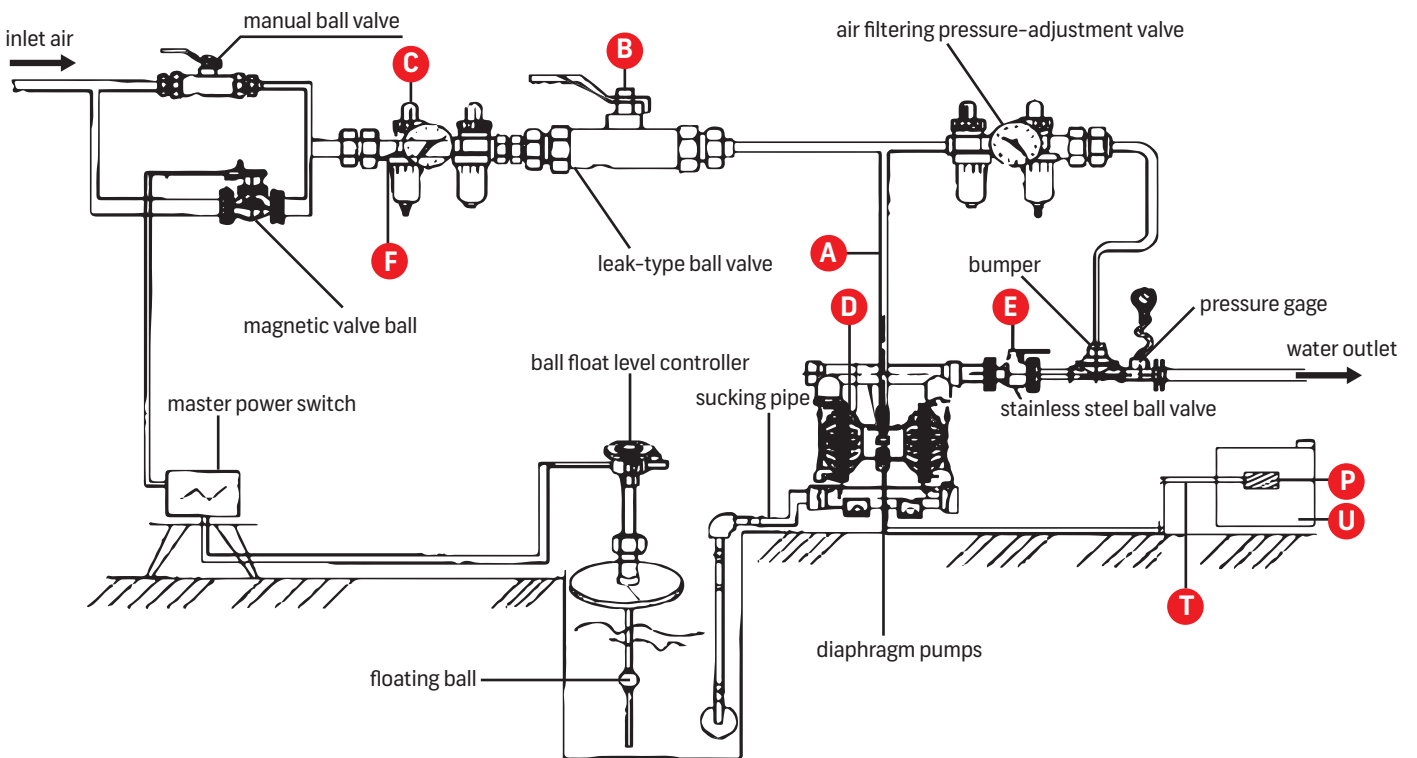

- | | | |
|---------------------------------|---------------------------------------|--------------------------------|
| A Gas Pipeline | D Intake Pipe Quick Connection | P Muffer |
| B Cuprum Ball Valve | E Leak Type Cuprum Ball Valve | T Exhaust Pipe |
| C Air Pressure Regulator | F Pneumatic FRL | U Container For Exhaust |



**LUBE
Control**

Lube Control Pty Ltd

Aluminium Air Operated Diaphragm Pump

DQBY40AAB/DQBY50AAB

PERFORMANCE GRAPH

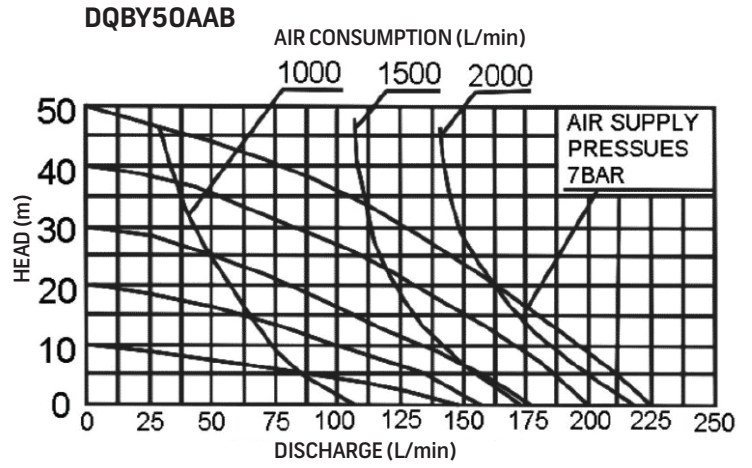
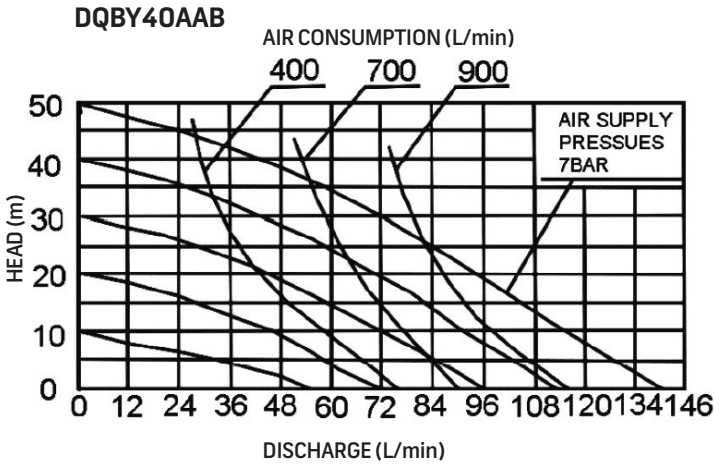

GENERAL SPECIFICATIONS

Type	Suction		Discharge		Type of connection				Material of pump body				
	inc	mm	inc	mm	NPT	BSPT	ANSI Flanged	DIN Flanged	Cast iron Z	Aluminium alloy L	Stainless Steel B	Engineering plastic PP/PVDF	Fluorinw Lined CF
DQBY40AAB	1 ½	40	1 ½	40	●	●	-	-	●	●	●	●	●
DQBY50AAB	2	50	2	50	●	●	●	●	●	●	●	●	●

MAIN SPECIFICATIONS

Type	Max Flow Rate (L/Min)	Discharge Pressure (Bar)	Sucked Lift(m)	Max Grain Diameter (mm)	Max Air Consumption (L/min)	Material Of Diaphragm					
						Buna-N	Neoprene	EPDM	Viton	Teflon	PP
DQBY40AAB	140	6.9	5	4.5	600	●	●	●	●	●	●
DQBY50AAB	240	6.9	5	8	900	●	●	●	●	●	●

MAIN EXTERNAL DIMENSION

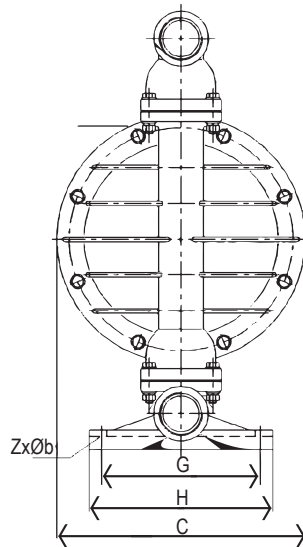
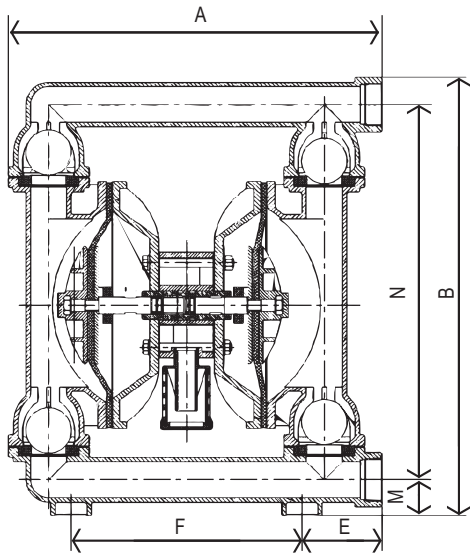

CODE	DQBY40AA	DQBY50AA
A	379	518
B	420	642
C	248.4	347
M	46	83
N	346	521
E	87.5	110
F	236	320
G	146	220
H	190	254
Z*b	4*12	4*14

(mm)



**LUBE
Control**

Lube Control Pty Ltd

Aluminium Air Operated Diaphragm Pump

DQBY40AAB/DQBY50AAB

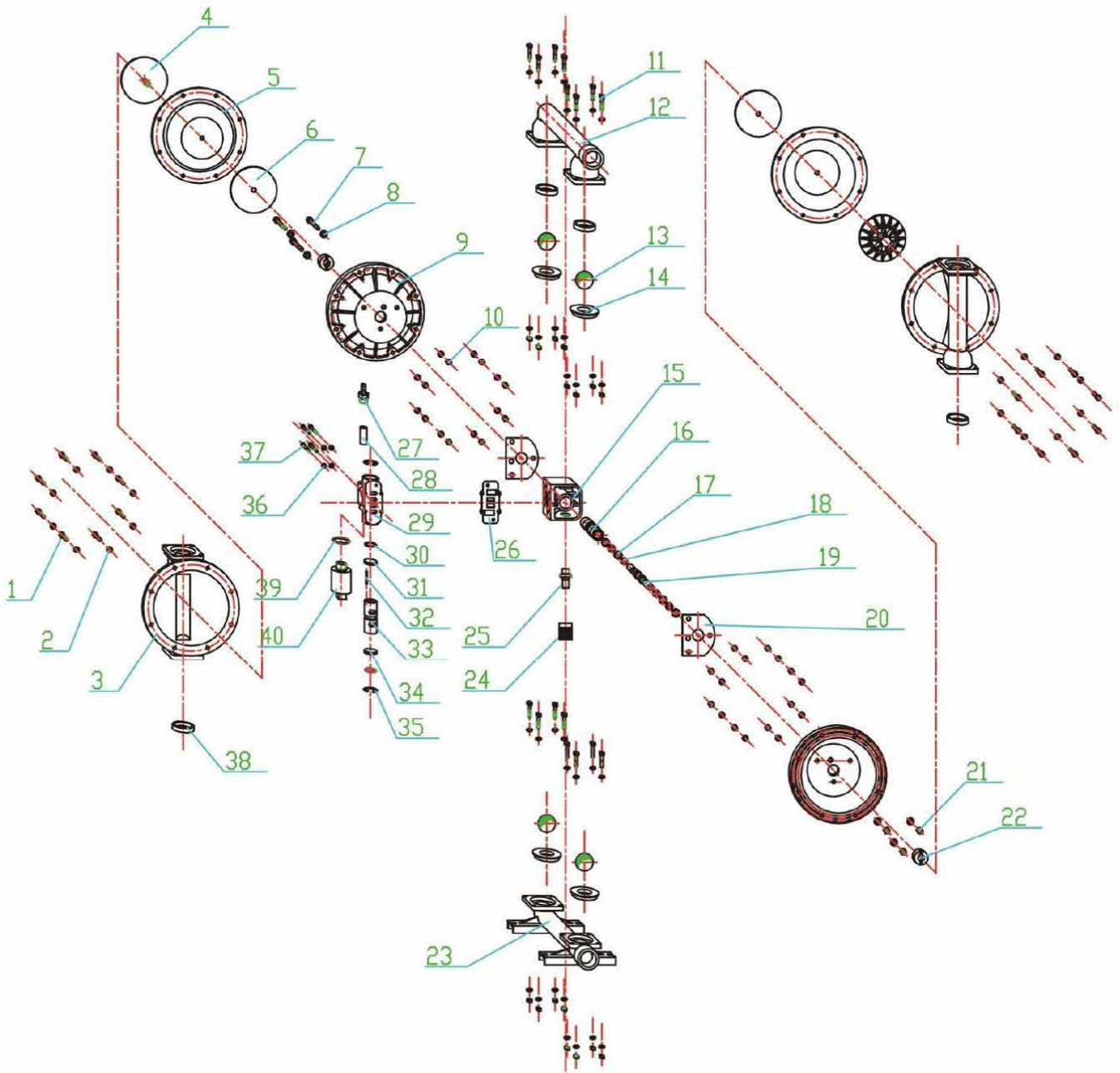

- | | | | |
|-------------------------|-------------------------|----------------------------------|--------------------------------|
| 1 Bolt | 11 Bolt | 21 Nut | 31 Baffle |
| 2 Gasket | 12 Up cover | 22 Site ring | 32 Site billot |
| 3 Stand column | 13 Ball | 23 Bottom cover | 33 Piston |
| 4 Outside platen | 14 Tee | 24 Muffler cover | 34 Baffle |
| 5 Diaphragm | 15 Pump body | 25 Muffler body | 35 Spring collar |
| 6 Endo platen | 16 Cuprum series | 26 Air valve gasket | 36 Spring cushion |
| 7 Bolt | 17 O-ring | 27 Air connector | 37 Bolt |
| 8 Gasket | 18 O-ring | 28 Into gases percolator | 38 Tee pressure annulus |
| 9 Clapboard | 19 Shaft | 29 Air distributive valve | 39 O-ring |
| 10 Nut | 20 Body gasket | 30 O-ring | 40 Oil cup |



**LUBE
Control**

Lube Control Pty Ltd

Aluminium Air Operated Diaphragm Pump

DQBY40AAB/DQBY50AAB

CHARACTERISTIC OF DIAPHRAGM

Variety Medium	Nitrile Rubber	Chloroprene Rubber	Fluorine Rubber	PTFE
Smoke nitric acid	X	X	△	△
Density nitric acid	X	X	△	△
Density sulfuric acid	X	X	○	△
Density hydrochloric acid	X	△	△	△
Density phosphoric acid	X	△	△	△
Density acetic acid	X	X	X	△
Density Sodium hydroxide	○	○	△	△
Non-aqueous ammonia	△	△	△	△
Thin nitric acid	X	X	○	△
Thin sulfuric acid	△	△	△	△
Thin hydrochloric acid	X	○	△	△
Thin phosphoric acid	X	X	△	△
Thin sodium hydroxide	○	○	△	△
Liquid ammonia	△	△	X	
Benzene	X	X	○	○
Gasoline	○	○	○	○
Petroleum	△	X	○	○
Carbon tetrachloride	○		○	○
Carbon disulphite	○		X	○
Alcohol	○	○	○	○
Acetone	X	△	X	○
Cresol	X	△	△	○
Acetic aldehyde	X	X	△	○
Ethylbenzene	X	X	△	○
Acryloniterile	△	△	X	○
Butanol	○	○	○	○
Butadience	○	X	△	○
Styrene	X	X	△	○
Vinyl acetate resin	X	X	X	○
Ether	X	X	X	○

NOTE: ○- means the long service life, △- means common service life, X- means use forbidden. This table is only considered from the anti-corrosion. Because the PTFE elasticity is worse than that in rubber. The actual use life will be affected because of the pressure and pump stroke factors.