



LUBE
Control

Lube Control Pty Ltd

Hose Reel Instruction Manual



860



Hose Reel

860

Technical Data

Item	Inlet/Outlet (Fitting)	Max Pressure (psi/bar)	Hose Capacity	
			I.D.(inch)	Max Length(ft/m)
L860152	1/4"	300/20	1/4"	50/15
L860153	3/8"	300/20	3/8"	50/15
L860154	1/2"	300/20	1/2"	50/15
M860152	1/4"	2750/189	1/4"	50/15
M860153	3/8"	2250/155	3/8"	50/15
M860154	1/2"	2000/138	1/2"	50/15
H860152	1/4"	5000/345	1/4"	50/15
H860153	3/8"	4000/276	3/8"	50/15

Dimensional Data

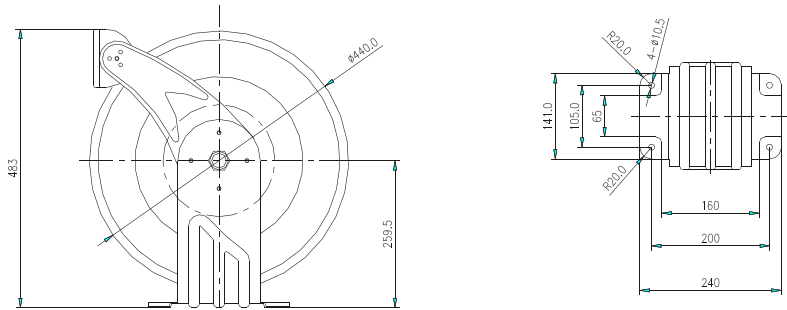

Personal Safety

Personal injury and/or equipment damage may result if proper safety precautions are not observed.
 Ensure that reel is properly installed before connecting input and output hoses.
 Bleed fluid/gas pressure from system before servicing reel.
 Before connecting reel to supply line ensure that pressure does not exceed maximum working pressure rating of reel.
 Remember, even low pressure is very dangerous and can cause personal injury or death.
 If a leak occurs in the hose or reel, remove system pressure immediately.
 Ensure that reel, hose, and equipment being service are properly grounded.
 If reel ceases to unwind or rewind, remove system pressure immediately. Do not pull or jerk on hose.



Hose Reel

860

Installation instruction

Prior to mounting the hose reel, ensure that the supply line pressure does not exceed the maximum working pressure of the hose reel.
Unpack and inspect reel for damage. Turn by hand to check for smooth operation. Check for completeness.
Position the reel on the floor, wall or ceiling. Secure into place using four mounting bolts.
Depending on where the reel is placed, it may be necessary to adjust the hose bumper and guide arm to use the hose properly. See the instructions on the next page to adjust the hose bumper and reposition the guide arm.

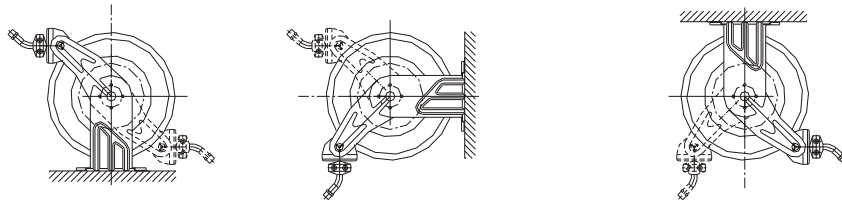

Adjustments

-Spring tension

Warning: Use extreme caution; reel under tension. Avoid releasing latch mechanism.

If necessary, adjust spring tension on reel by adding or removing wraps of hose from spool, one wrap at a time, until desired tension is obtained. Add wraps to increase tension.

Remove wraps to decrease tension.

Pull out the hose until the latch pawl is engaged. Loosen the hose bumper, then add wraps and decrease the wraps.

Caution: When adding wraps of hose, be careful not to exceed the winding mechanism's spring capacity. Add just enough wraps of hose to achieve the desired tension.

Damage to the winding mechanism will result if spring is over-tensioned.

-Adjusting the hose bumper

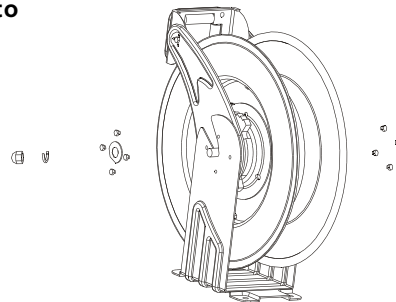



Hose Reel

860

Pull out the hose until the latch pawl is engaged. The hose bumper may be adjusted by loosening the slotted screws. Slide the bumper to the desired position and tighten the screws before pulling hose to disengage the latch pawl.

-Removing and positioning Guide Arm

Pull out hose until the latch pawl is engaged. Remove bumper by removing the slotted screws.

Disengage the latch pawl while maintaining a firm hold on spool. Turn the spool hand over hand approximately two or three revolutions in the direction of the direction of the drive spring until tension is removed.

Remove the nuts and washer holding the guide arm and shift to base.

Revolute the guide arm and adjust to any of the three positions hinted.

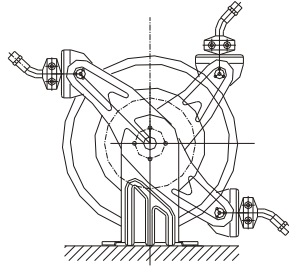

According to each mounting application, recommend Guide Arm positions.

Replace and tighten the nuts and washer.

Tighten the drive spring by turning the spool two or three revolutions and engage the latch pawl.

Pull the hose through the roller opening in the guide arm and replace the hose bumper.

Service Instructions

CAUTION: Remove all tension before servicing. Hazards or unsafe practices MAY result in *minor* personal injury, product or property damage.

Warning: Before performing any service, always disconnect and lock out compressed air or fluid, and remove all spring tension. Hazards or unsafe practices COULD result in severe personal injury or death.

User servicing of the reel is limited to replacing input/output hoses only. Refer all other repairs to an authorized service person. Failure to do so can result in person injury and/or equipment damage and may void the warranty.



Hose Reel

860

-Replacing the hose

To remove the hose

Pull out the hose leaving 2 to 3 feet on the spool. Engage the latch pawl.

Unthread the hose at the connection to the swivel tube. Remove the hose.

To install the hose

Route the hose through the guide arm rollers and opening of the spool. Apply thread tape or sealant to hose threads.

Screw hose fitting into threaded fitting on swivel. Tighten connection with a wrench on fitting. Install hose bumper on working end of hose if required.

Disengage latch pawl and allow hose to retract.

-Replacing the swivel

If the swivel leak, replace the O-ring or seal (31) and washer (30) by removing the lock washer (33) and the part of the swivel shift.

If the balls (36) wear-out, replace by removing the lock washer (39).

Replace the New seal by clipping the lock washer (33). Replace the part of the swivel shift by clipping the lock washer (39).

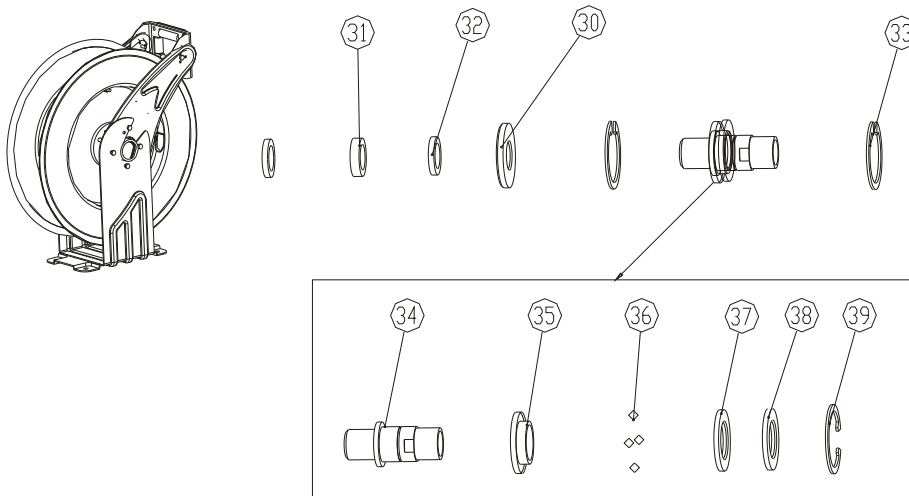



LUBE
Control

Lube Control Pty Ltd

Hose Reel

860

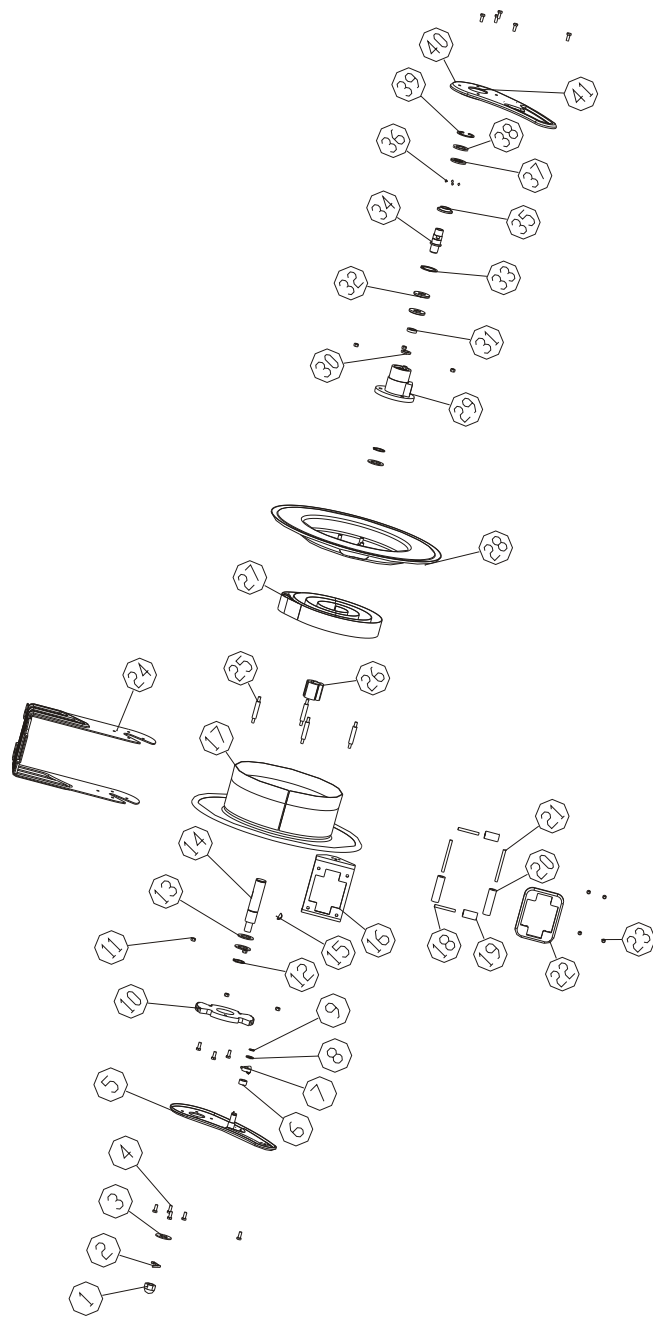



Hose Reel

860

860 Parts List

Part	Item	Qty.	Part	Item	Qty.
1	Nut	1	21	Roller axle	2
2	Spring washer	1	22	Guide plate	1
3	Bolt	2	23	Bolt	4
4	Washer	10	24	Base	1
5	Bracket arm	1	25	Double bolt	4
6	Washer	1	26	Spring dog	1
7	Ratchet	1	27	Spring	1
8	Washer	1	28	Drum	1
9	Lock washer	1	29	Swivel shaft	1
10	Click pulley	1	30	Wahser	1
11	Nut	10	31	O-ring or seal	1
12	Lock washer	1	32	Washer	2
13	Washer	3	33	Lock washer	2
14	Shaft	1	34	Swivel shaft	1
15	Key	1	35	Bearing cover	1
16	Guide sub-plate	1	36	Ball bearing	22
17	Drum	1	37	Bearing washer	1
18	Roller axle	1	38	Washer	1
19	Roller	1	39	Lock wahser	1
20	Roller	1	40	Bracket arm	1
			41	Shaft sleeve	1