

## MACNAUGHT POLY DIESEL TANK KITS

### INSTRUCTION MANUAL



#### AVAILABLE TANK KITS

- MDT100L Tank (40l/min pump)
- MDT200L Tank (40l/min pump)
- MDT300L Tank (40l/min pump)
- MDT400L Tank (40l/min pump)
- MDTN400L Narrow Tank (40l/min pump)
- MDT600L Tank (40l/min pump)
  
- MDT800L-60LPM (60l/min pump)
- MDT1000L-60LPM (60l/min pump)
- MDT1200L-60LPM (60l/min pump)
  
- MDT800L Tank (85l/min pump)
- MDT1000L Tank (85l/min pump)
- MDT1200L Tank (85l/min pump)

**WARRANTY**  
5 Years - Pump \*  
15 Years - Tank \*

# DIESEL TANK KITS

## INSTRUCTION MANUAL

### INTRODUCTION

Thank you for purchasing a Macnaught Diesel Fuel Tank Kit.

The Macnaught tank kits are supplied, complete with Delivery Nozzle, 12volt pump, Delivery Hose, Power Cable and Alligator Clips.

Macnaught also have a complete range of retractable hose reels, fuel nozzles, fuel meters, air operated or manual oil pumps and a full range of greasing equipment available to suit all of your fluid handling requirements.

### GENERAL INFORMATION

This manual assists you in operating and maintaining your Macnaught diesel tank kit. The information contained will help ensure many years of dependable trouble free operation.

Please read and retain this instruction manual to assist you in the operation and maintenance of this quality product. If you require any further assistance please contact your local Macnaught distributor.

### DESCRIPTION

The Macnaught tank kits have been designed to safely hold and reliably transfer diesel.

The pump included with this kit is a self priming, positive displacement, rotary vane pump, operating on 12 volts DC. The pump delivers up to 40 ltr/min or 85ltr/min depending on the pump model fitted, has a built-in bypass valve that keeps the operating pressure below 1.3 Bar (18 psi) and the motor has a 30 minute duty cycle.

**Note** - This pump must not be used in bypass mode (nozzle closed) for more than 2 minutes otherwise serious damage to the motor will occur.



#### CAUTION

ONLY USE this pump kit with diesel, failure to do so may cause personal injury or damage the pump which will void pump warranty.

### SAFETY INFORMATION

1. When mounting tank to any vehicle, ensure that you comply with all weight restrictions specified by the vehicle manufacturer as overloading can cause serious injury.

2. You must comply with all relevant environmental, work place health and safety legislation and codes of practice including the requirements of AS1949-2004 (storage and handling of flammable and combustible liquids)

3. Ensure the tank is correctly and securely fitted to the vehicle.

4. Take care at all times, especially when operating on rough or steep terrain. Drivers need to be aware of the effects of fluid surge at all times.

5. Minors should never be allowed to use this tank.

6. This diesel tank is solely designed for use with diesel, under no circumstances should it be used for any other purpose.

7. Ensure that all operators of this unit understand its safe operation and have access to all the instruction manuals supplied with the unit.

8. Before operating this unit ensure that all operators have read and understand all safety warnings attached to the tank or pump.

9. Avoid diesel contact with skin and eyes, and avoid breathing any vapours.

10. This unit should never be left unattended while the pump is being filled or is operating.

11. Do not store tank within or next to a dwelling or garage attached to a dwelling.

12. Store tank in a well ventilated area.

13. No combustible or waste materials should be placed around or near the diesel tank.

14. Any spillage shall be cleaned up immediately and materials used in the clean up shall be disposed of safely and in accordance with any relevant local regulations.

**RISK ASSESSMENT SHEET**

Task	Hazard	Risk	Control Measures
Partially fill tank with diesel connect 12 volt transfer kit and test unit operation.	Manual handling: slips trips or falls: Electricity: static	Medium	Concentrate on the task at hand: follow safe manual handling techniques: don't lift on your own, if 20kg bend knees & keep back straight: keep fingers clear: keep unit at least 8m from overhead power lines: use supplied earth lead in specified manner: tank mounting to comply with the relevant codes of practice and transport authority requirements
Check weather conditions & select the appropriate PPE to suit operation of the unit	Manual handling: slips, trips or falls: diesel contact and fumes/vapours	Low	Use PPE as per chemical requirements in the material data safety sheet - coveralls, gloves, safety footwear, glasses & respirator: follow safe manual handling techniques
Fill the diesel tank	As above: diesel fumes, diesel spillage, diesel vapour, and combustibility: weather conditions: untrained operators: tank not secured: tank used for non diesel products	Medium	Follow the relevant Environment Protection Authority requirements: fire extinguisher on hand - CO2 or powder: keep other personal away unless wearing appropriate PPE: check load security: operate with diesel only in accordance to "Diesel Only" sticker.
Check that transport vehicle is safe before use: wheel nuts, tyre pressure, bearings, tow hitch, service history, etc: operate diesel unit.	As above: loss of load: heat or cold: noise of pump & vehicle: exceeding load limit of vehicle: load security: hose entanglement: exhaust fumes: terrain	High	As above: wear suitable clothes: wear hearing protection if noise is above 85dBa: Follow the manufacturer's safe operating procedures: do not overload diesel (approx 0.85kg per ltr): Secure load to vehicle check earth straps: hoses tidy
Clean up, maintenance & storage	As above. Confined space inside tank	High	As above: continue to wear PPE for clean up: follow state legislation & AS2865:2001 safe working in a confined space guidelines: store tank in a dry well ventilated area.

 **WARNING**

This tank is classified as 'Minor Storage' for class C1 combustible liquids when operated correctly in compliance with AS 1940-204.

Before using this tank - operators should familiarise themselves with the requirements of this standard.

The earthing wire on the tank should be attached to an appropriate metal earthing point on the tank to be filled or earthed to ground.

**Note:** The earthing wire must be attached to the frame of the pump

This wire shown below is to prevent the fill cap from being lost or misplaced



**WARNING NOTICES**

A copy of the stickers attached to the tank are shown below. Please ensure that these instructions are followed. Safety decals should be kept clean and legible at all times. If any decals are missing or unreadable, they should be replaced by ordering new decals please contact Macnaught for details



## OPERATION

Your diesel unit is supplied with a comprehensive instruction manual. Ensure that all operators read and understand and have access to this manual before using your diesel unit.

## TANK SET UP AND INSTALLATION

**MOUNTING.** Your tank comes assembled and ready for operation: however before operation it is important that you ensure the tank is installed correctly. There are two ways of securing your tank.

1. Tank comes with molded in recessed areas for strapping down lengthways.

PLEASE NOTE: this method is designed as a temporary means of securing the tank to the vehicle in situations where the tank needs to be moved frequently.

2. For more permanent installations brass inserts have been molded into the base of the tank. When using these inserts to mount your tank, ensure you use the correct length bolt for the task, to prevent damage to the tank.

**PRE-OPERATIONAL CHECK.** Before operating the unit, perform a pre-operation check to ensure that damage has not occurred during deliver of the unit.

1. Check all fittings and hoses for tightness and damage.
2. Check tank, including base for any excess abrasion or transport damage.
3. Check electrical leads, note any abnormalities or damage.
4. Remove the filler cap and filter and gun from holder. Ensure all moving parts operate freely.

### CONNECT TO POWER SOURCE (where applicable)

It is essential that your pump is connected to a power source in accordance with local electrical and vehicle safety legislation. When connecting your pump please note the following points.

1. For 12VDC pumps, use appropriate vehicle power source or supply (12v)
2. It is strongly recommended that you use qualified auto electrician if connecting the pump to the vehicle permanently.
3. All installations must be fused appropriately in accordance to the pump manufacturers specifications. (refer to pump specifications)
4. **If mounting the unit to a vehicle permanently it is recommended that a molded pair type Anderson plug rated at least 50A be used.**

**Note: An inline fuse must be installed otherwise warranty will be void**

**Refer to pump manual supplied for further information**



## TANK FILLING PROCEDURE:

Follow procedure must be followed for filling tank.

1. Ensure the tank is in an adequately ventilated area.
2. Use the earth lead supplied to ground tank to an earth stake or to the earth point provided at the refueling depot.
3. Remove the filler cap, inset the supply nozzle into the filler opening, operate the supply and fill to the desired level.
4. Remove the filler nozzle from the tank, replace the cap.
5. Remove the static lead.

## TEST UNIT:

Before using unit for refueling it is recommended that you check operation of the unit by inserting the nozzle into the tank filler neck and running the pump for a short period of time.

## REFUELLING PROCEDURE:

Follow the following refueling procedure.

1. Ensure the tank to be filled is in a well ventilated area, and within reach of the refueling hose.
2. Using the static lead supplied, ground the tank to be refueled by attaching the lead to the chassis or other metal component near the tank.
3. Remove the fuel cap from the tank and insert the nozzle.
4. Turn on pump and fill tank. **Important:** the auto nozzle will shut off automatically when the tank is full. Never leave the tank or nozzle unattended while filling.
5. Turn off the pump:

**NOTE: during the course of normal operation, the pump will work in by pass mode. If the nozzle is shut or restricted. This is usually indicated by a change in tone (noise).**

**NOTE: Pump must not run for any longer than 3 minutes in this state, as this will void warranty.**

4. Remove nozzle and replace filler cap.
5. Disconnect static lead.

## PACK UP AND DECONTAMINATION

After you have completed refueling for the day, ensure you pack nozzle and delivery hose away neatly to prevent tangles or hose kinks. If any spillage has occurred, ensure this is cleaned up in accordance with local environmental and safety regulations.

NOTE: Store diesel unit only in a dry well ventilated area, free of any sources of fuel or ignition.

## TANK MAINTENANCE

You Macnaught tank has been designed and built to require minimal maintenance, however it is recommended that you follow the maintenance procedures below.

### Tank unit

Periodically check the external condition of the tank for any signs of damage. Assess damage and replace if required.

### Hose

Check hose for damage and replace if found to be damaged, cracked or worn.

### Fittings

Check all fittings for any signs of leakage and tighten all fittings as required.

### Filter

Check filter for contamination. Flush and clean as required.

### Pump

Keep the pump exterior clean to help identify leaks, check all connections / joints for correct sealing and repair any leakage immediately. Check electrical cable for any signs of damage or cuts and replace cable if required.

**Note:** It is recommended that the delivery hose is replaced annually

### Disposal of contaminated materials

Dispose all contaminated parts correctly. Refer to local regulations for proper disposal if contaminated parts and materials.

## PUMP INSTRUCTIONS

### Connection using battery clips

1. Connect the alligator clips on the motor power cord to a suitable battery which is capable of delivering the necessary voltage and current (see the Technical Data, back page of this manual)
- 2) Attach the RED clip to the positive (+) battery terminal.
- 3) Attach the BLACK clip to the negative (-) battery terminal or to the vehicle frame.

### Note:

**The inline fuse must not be removed otherwise warranty will be void**



## PUMP INFORMATION

**NOTE:** Avoid sparks that could cause a fire:

**DO NOT** use a patch cord to extend the power cables.

**DO NOT** let the pump run dry for more than 3 minutes.

1. Before use, wipe off any dirt or moisture that may have accumulated on the nozzle or hoses.
2. Operate the nozzle lever to dispense fluid.
3. Immediately switch motor off after use.
4. Nozzle and hoses should be kept clean and dry when not in use.

## PUMP MAINTENANCE

### Important:

Do not modify any part of the unit or any warranty on the product will be automatically void.

1. Inspect and clean tank strainer monthly.
2. Always clean the battery terminals and clips before use to ensure a good connection.
3. Always relieve the line pressure by opening the nozzle, draining hose. Disconnect power before starting any pump maintenance
4. Hoses should be inspected annually.  
(Replace if found to be cracked or worn)
5. The rotor and vanes will eventually wear. They should be replaced if pump performance degrades.  
(refer to trouble shooting guide)
6. If the tank is not used for extended periods, please pour 200ml of oil from the suction side and ensure pump vanes are wet enough before starting to use these tanks.

## ELECTRIC DIAGRAM (For 85lpm pump only)

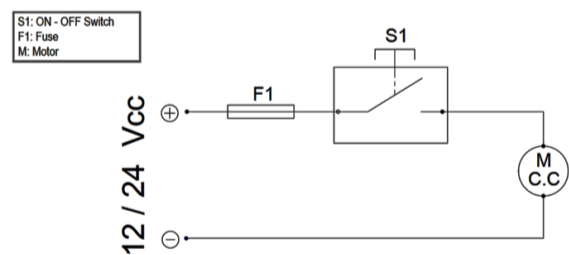

## Electrical Selection Table (minimum requirement)

**Note:** the total cable length is from pump to power source

Pump Model	Fluid	Flow Rate	Power Supply	Fuse	Total Cable Length	Minimum Wire Section	
AFP12A/M	Diesel	40 LPM	12 VDC	30A	0 - 4 m	2.5 mm <sup>2</sup>	13 AWG
					4 - 6 m	4 mm <sup>2</sup>	11 AWG
					4 - 8 m	6 mm <sup>2</sup>	9 AWG
AFP24A/M	Diesel	40 LPM	12VDC	15A	0 - 4 m	2.5 mm <sup>2</sup>	13 AWG
					4 - 8 m	4 mm <sup>2</sup>	11 AWG
AHP85L-12V	Diesel	85 LPM	12VDC	30A	0 - 4 m	6 mm <sup>2</sup>	9 AWG
					4 - 6 m	10 mm <sup>2</sup>	7 AWG
					6 - 10 m	16 mm <sup>2</sup>	5 AWG

Note - If length of wiring is increased, it must respect the table above as far as minimum wire selection. Fuse

**DIAGRAM FOR 100L - 600L Tanks**

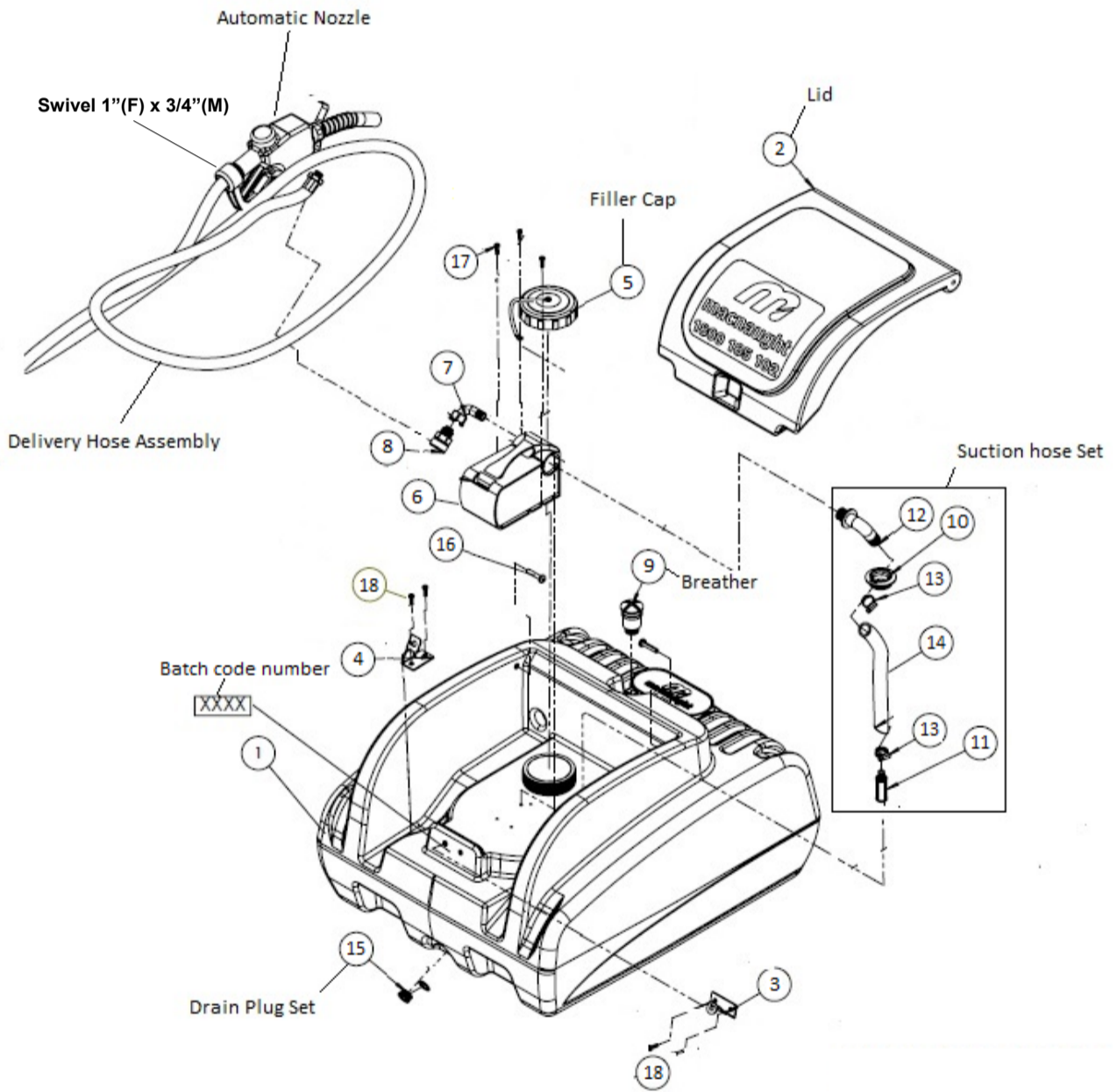

Item	Description	No off
1	Tank	1
2	Tank Lid (small) - 100L/200L/300L/400L Narrow Tanks	1
2	Tank Lid (medium) - 400L/600L Narrow /600L Tanks	1
3	Lid locking bracket	1
4	Auto nozzle holding bracket	1
5	Tank filler cap	1
6	12 volt pump - 40L/min	1
7	Elbow - 1" Barb x 3/4" BSPP (M)	1
8	Swivel - 3/4" BSPP (M/F)	1
9	Tank Breather	1
10	Tank to suction hose seal	1
11	Strainer with 1" barb	1
12	Elbow 3/4" BSPP (M/F)	1
13	Hose clamp (21-44mm)	2
14	Suction hose 1" (PVC with steel wire)	1
15	Tank drain plug (with gasket)	1
16	Screw - M8 x 40 (philips head)	2
17	Screw - M6 x 20 (pozi -drive)	3
18	Screw - M6 x 12 (philips head)	4
19	Automatic nozzle	1
20	Delivery Hose Assembly	1

**Available Tank Spare parts and kits**

Item no's	Description	Part number to order
	Automatic Nozzle	L-FNAD
	Delivery hose (100L -600L) 4m x3/4" I/D - 3/4"BSP (M) x 1"BSP (M)	L-H19254
6	12 volt pump assembly - 40L/min (up to 600L tank)	AFP12-40LP
2	Tank Lid (small) - 100L/200L/300L/400L Narrow Tanks	SP-MDT-0001
2	Tank Lid (medium) - 400L/600L Narrow /600L Tanks	SP-MDT-0002
5	Tank Filler Cap	SP-MDT-0003
9	Tank Breather	SP-MDT-0004
10,11,12,13,14	Suction hose and fitting set (100L tank)	SP-MDT-0005
10,11,12,13,14	Suction hose and fitting set (200L-300L-400L-600L tanks)	SP-MDT-0006
10,11,12,13,14	Suction hose and fitting set (400L Narrow tank)	SP-MDT-0007
15	Tank drain plug and gasket	SP-MDT-0008
8	Swivel - 3/4" (100L - 600L Tanks)	SP-MDT-0009
8	Swivel - 1" (800L - 1200L Tanks)	SP-MDT-0012
Not shown	Earthing cable	SP-MDT-0013
12	Elbow - 1" Barb x 3/4"BSP	SP-MDT-0014
3	Tank locking bracket	SP-MDT-0019
4	Gun holding bracket	SP-MDT-0020

**DIAGRAM FOR 800L - 1200L Tanks**

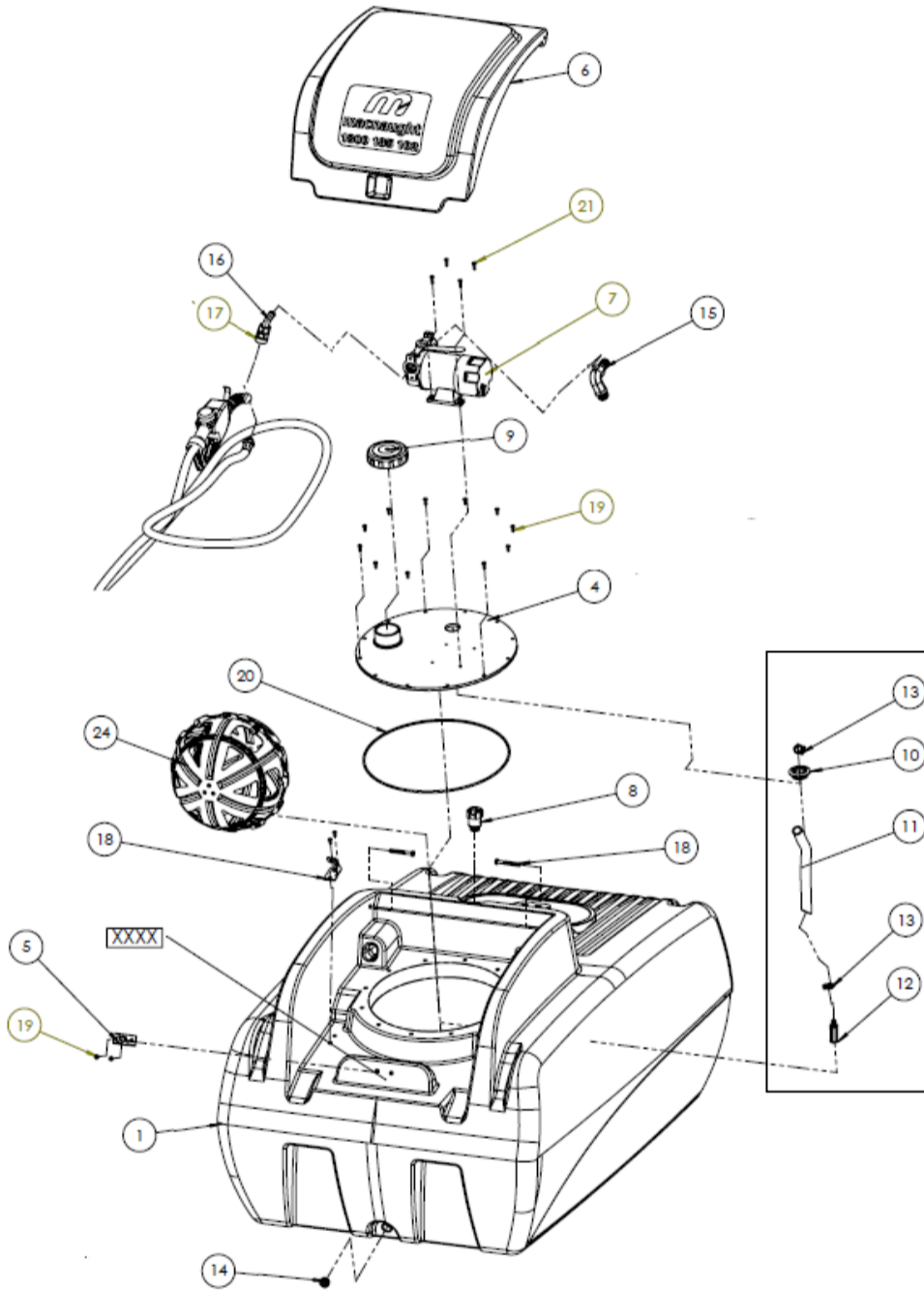

Item Number	Description	No off
1	Tank 800L	1
2	Tank 1000L	1
3	Tank 1200L	1
4	Filler cover plate	1
5	Tank lid locking bracket	1
6	Tank Lid (large)	1
7	AHFP85L - 12 volt pump	1
8	Breather 3/4"	1
9	Filler cap assembly	1
10	Tank / suction hose seal	1
11	Suction hose	1
12	Strainer with 1" barb	1
13	Hose clamp (21-44mm)	2
14	Drum bung (with gasket)	1
15	Swivel - elbow male 1" BSPP x 1" barb	1
16	Elbow male 1" BSPP M/F	1
17	Swivel - 1" M/F with o'ring	1
18	Gun holding bracket	1
19	Screw - M6 x 16 (philips head)	16
20	O'ring BS386	1
21	Screw - taptite M6x20	4
22	Label - Caution	1
23	Label - Diesel fuel only	1
24	Baffle Balls MDT1000L / MDT1200L	23/23

**Available Tank Spare parts and kits**

Item no's	Description	Part number to order
	Automatic Nozzle	L-ANHF
	Delivery hose assembly	MDT053
7	12 volt pump assembly	AHFP12-85LP or ADP12A-60LP
6	Tank Lid (large)	SP-MDT-0010
9	Tank Filler Cap	SP-MDT-0003
8	Tank Breather	SP-MDT-0004
10,11,12,13	Suction hose and fitting set (800L tank)	SP-MDT-0007
10,11,12,13	Suction hose and fitting set (1000L tanks)	SP-MDT-0007
10,11,12,13	Suction hose and fitting set (1200L tank)	SP-MDT-0011
14	Tank drain plug and gasket	SP-MDT-0008
17	Swivel - 1"	SP-MDT-0012
N/A	Swivel - 3/4"	SP-MDT-0009
not shown	Earthing Cable	SP-MDT-0013
6	Tank Locking bracket	SP-MDT-0019
18	Gun holding bracket	SP-MDT-0020
15	1" Swivel	SP-MDT-0014

Pump supplied on 100 - 600L Tanks

**AFP12-AK PARTS LIST**

Item	Description	No Off
1	Pump body	1
2	Motor	1
3	Base plate	1
4	By pass cap	1
5	By pass spring	1
6	By pass valve	1
7	Pump seal	1
8	O'ring	1
9	Drive key	1
10	Rotor	1
11	Vane set	5
12	Tie rod screws	2
13	Face plate screws	3
14	Switch	1

**Available accessories**

- Manual Nozzle
- Automatic nozzle
- Delivery hose
- Suction hose and strainer set
- For wet seal kit order AFP12-1K
- For poppet valve set order AFP12-2K

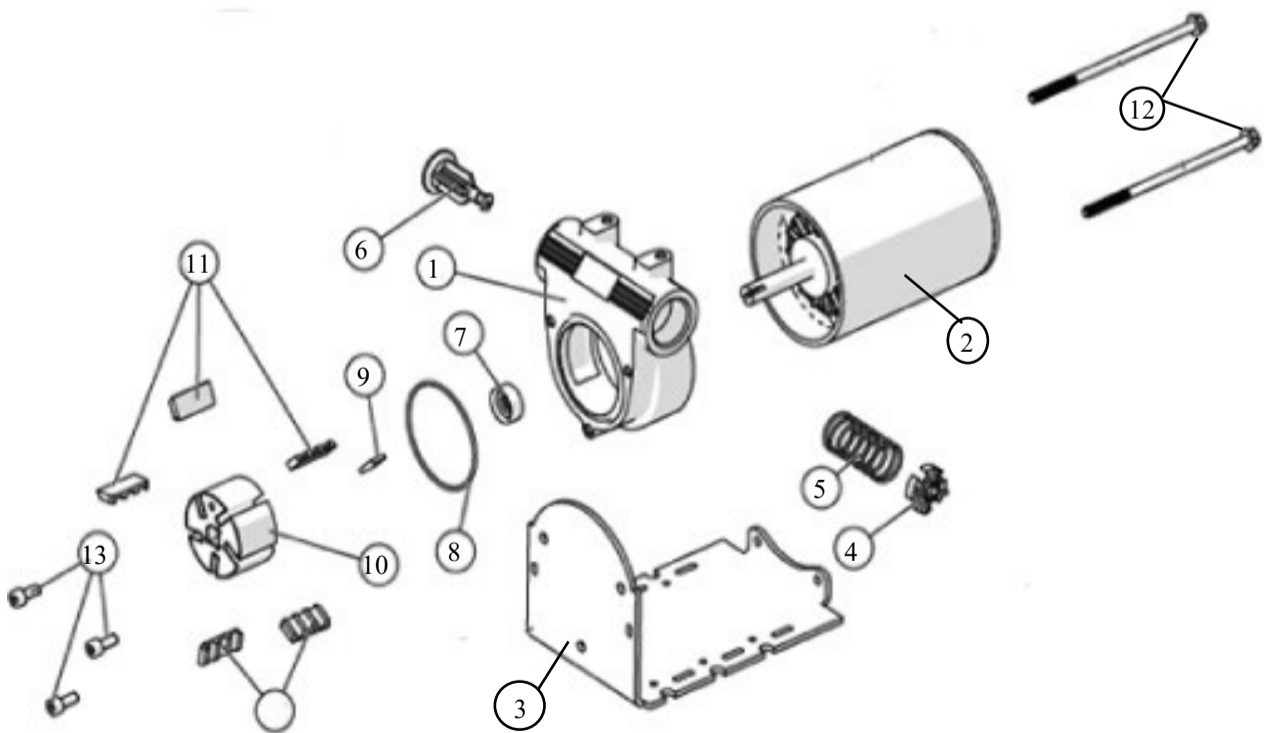
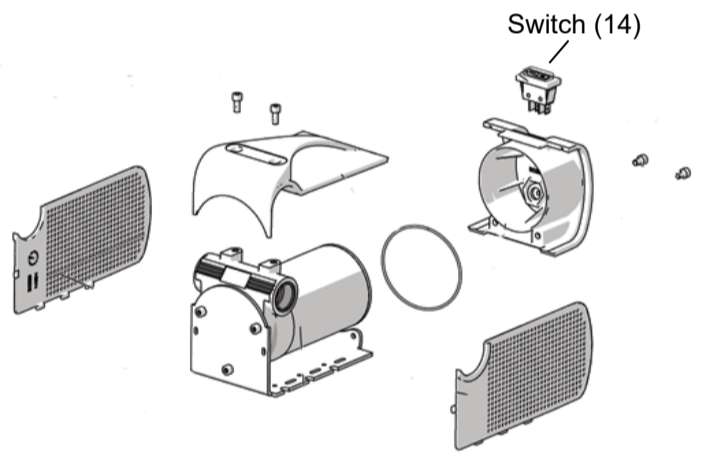

### 40 LTR/ MIN PUMP

Poppet valve assembly / disassembly

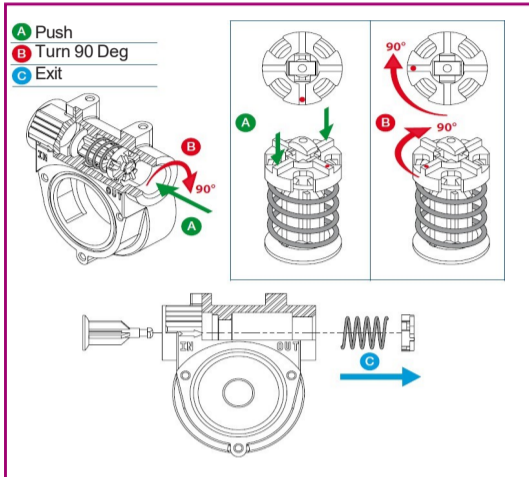

Correct seal orientation

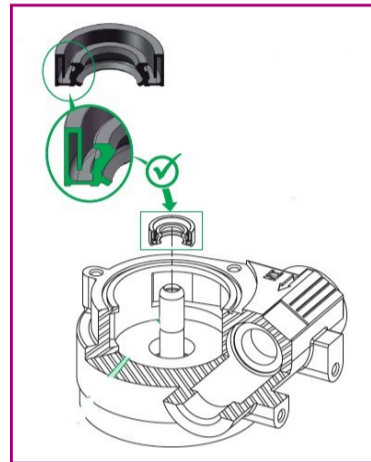

Correct vane and rotor orientation

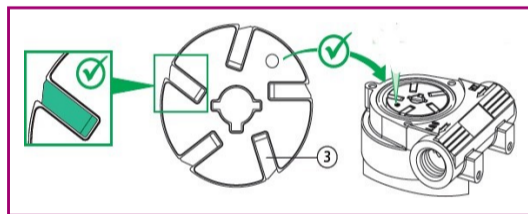

### 40 LTR / MIN PUMP DIMENSIONS

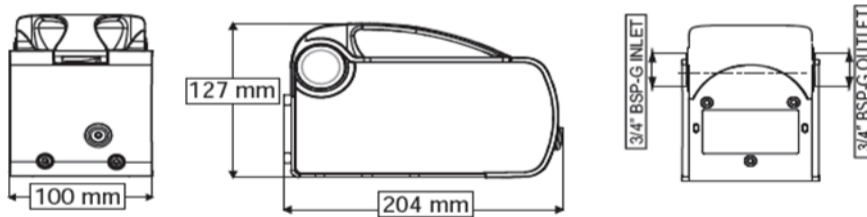

### 85 LTR / MIN PUMP DIMENSIONS

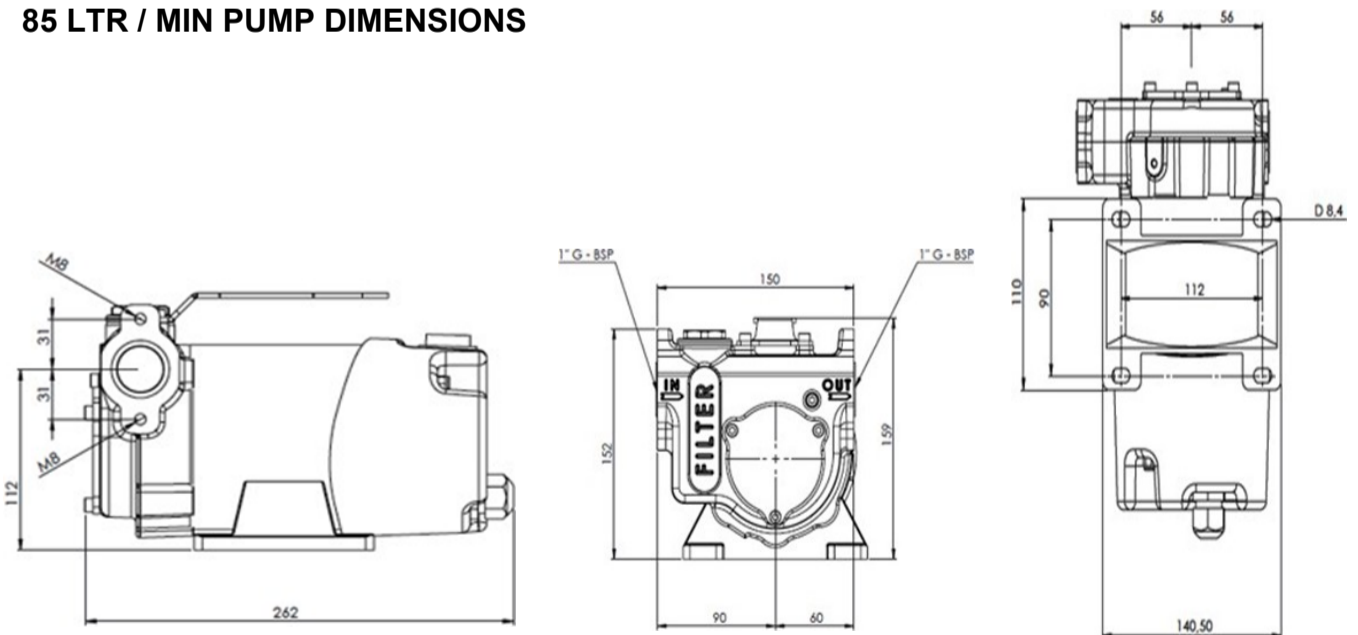

Pump supplied on 800 - 1200L Tanks

**AHFP85L-12A PART LIST**

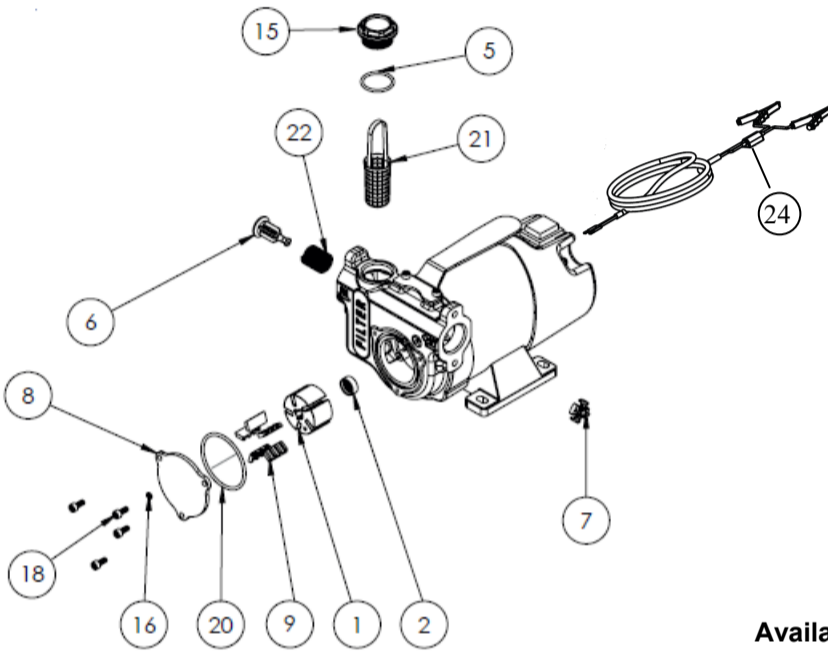

Item	Description	No Off
1	Rotor	1
2	Seal	1
5	O'ring	1
6	By Pass Valve	1
7	Disc	1
8	Cover Plate	1
9	Vaness	5
15	Strainer Cap	1
16	O'ring	1
18	Cover Screws	6
20	O'ring	1
21	Strainer Basket	1
22	By Pass Poppet Spring	1
23	Switch	1
24	40 Amp Fuse Holder	1

**Available Accessories**

- Automatic Nozzle  
For Seal Kit order AHFP85L-1K
- For electric on/off switch order AHF-SWITCH

**Poppet valve and strainer assembly/disassembly**

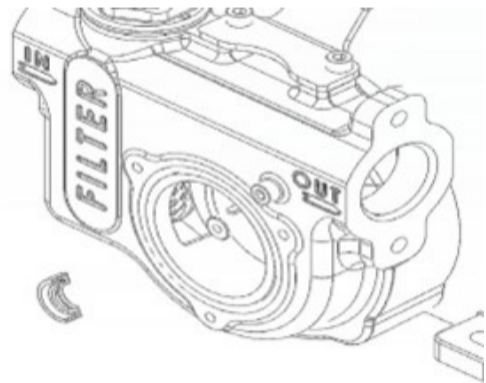
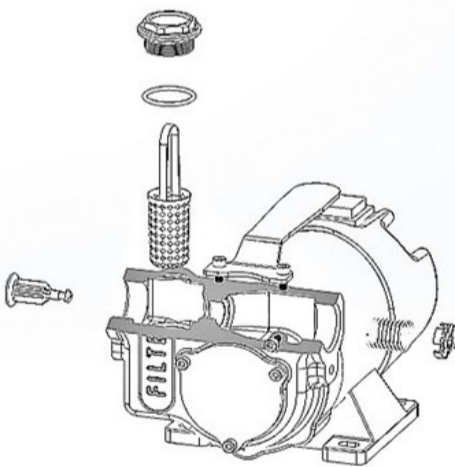

Correct seal orientation

**NOTE:**  
Assemble with dimple down and fit the vanes in the correct orientation as shown

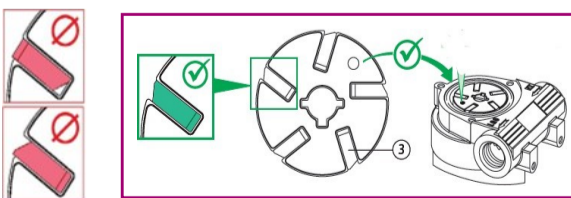

Pump supplied on  
MDT800L - 60LPM Tank  
MDT1000L-60LPM Tank  
MDT1200L-60LPM Tank



**ADP12A-60LP**

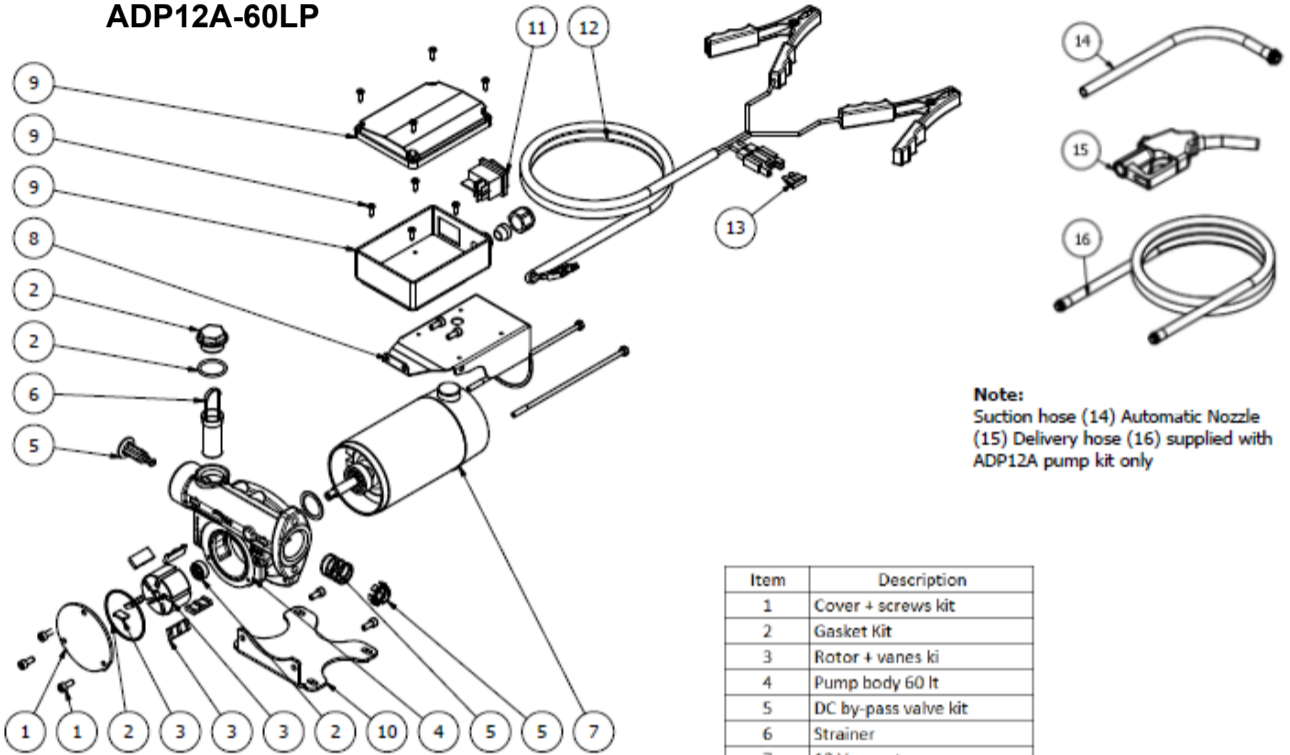

**Note:**  
Suction hose (14) Automatic Nozzle  
(15) Delivery hose (16) supplied with  
ADP12A pump kit only

Item	Description
1	Cover + screws kit
2	Gasket Kit
3	Rotor + vanes ki
4	Pump body 60 lt
5	DC by-pass valve kit
6	Strainer
7	12 Vcc motor
8	FLC 60 DC cover kit
9	Electrical box kit
10	FLC 60 DC bracket kit
11	ON/OFF Switch
12	Cord 2x4 4mt + clamps
13	25A fuse (12 Vcc motor)

**Available Service Kits**

- SPADP12A-1K - Pump wet end service kit (parts 2 & 3)
- SPADP12A-2K - Popper Valve set (part 5)
- SPADP12A - Switch - On/Off Switch (part 11)

Type	Tension V (+/-5%)	Power max W	Current nom. A	Current max. A (by-pass)	Fuse	Port	Weight Kg
ADP12A-60LP	12	336	19	25	•	1"	5,2

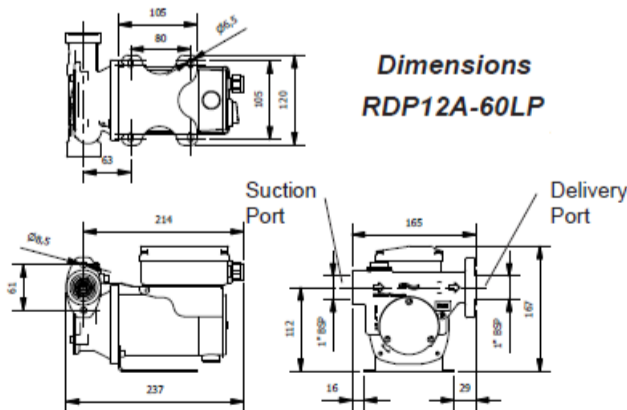

### Trouble Shooting Guide - all tank pumps

<b>Problem</b>	<b>Cause</b>	<b>Solution</b>
Pump fails to start	1 Suction hose/tube has a blockage 2 Outlet is blocked  3 Bypass poppet not closing 4 Vanes sticking  5 Excessive vane or rotor wear  6 Leak from front o'ring	1 Clear blockage from suction hose/tube 2 Check outlet hose and nozzle for blockage and correct operation 3 Check bypass valve is closing correctly 4 Check vanes are sliding freely in the slots (remove burrs or replace vanes if required) 5 Replace rotor and/or vanes  6 Check o'ring for correct sealing, replace if required
Pump vibrates but does not turn	1 Dirt jammed inside the pump  2 Faulty motor 3 Broken rotor key	1 Clean pump chamber  2 Replace pump 3 Replace rotor key
Low flow	1 Blocked strainer 2 Restriction on the inlet or outlet 3 Excessive rotor or vane wear 4 By pass poppet blocked 5 Low fluid level in tank	1 Clean or replace strainer 2 Incorrect size hoses used on inlet or outlet 3 Replace worn or damaged components 4 Check poppet valve for correct operation 5 Fill tank
Motor overheating	1 Fluid too thick (viscous) 2 Motor running longer than 30 minutes  3 Blocked suction hose 4 Blocked strainer	1 Fluid to be no thicker than Diesel 2 Pump must only run for 30 minutes before cooling 3 Clean blockage from suction hose 4 Clean strainer
Motor not turning on	1 Poor electrical connection 2 Battery low or faulty 3 Blown or faulty fuse 4 Faulty switch	1 Clean terminals and battery clamps 2 Check battery 3 Check pump and or replace fuse 4 Replace switch
Pump leaking out of weep hole	1 Worn or damaged shaft seal  2 Fluid compatibility	1 Replace seal  2 Only use compatible fluid



**AFP12 (40LPM) PUMP SPECIFICATIONS**

Maximum flow	40ltr/min
Maximum pressure	1.3bar
Voltage	12volt
Current	18 amp
Duty cycle	30 min
Fuse	30 amp
Inlet /outlet	3/4 BSPP (F)
Temperature	-20 deg C / +50 deg C
Wetted materials	Cast iron, Sintered steel, POM, NBR
Maximum prime height	2m
Motor protection rating	IP55

**AFP85L (85LPM) PUMP SPECIFICATIONS**

Maximum flow	85ltr/min
Nominal pressure	10bar
Voltage	12volt
Current	40 amp
Duty cycle	30 min
Fuse	40 amp
Inlet /outlet	1"BSPP (F)
Temperature	-20 deg C / +50 deg C
Wetted materials	Zinc plated steel, Cast iron, Sintered steel, POM-C, NBR AISI304
Maximum prime height	2m
Motor protection rating	IP55



**Macnaught Pty Limited**  
ABN 66 000 075 785

41-49 Henderson Street  
Turrella NSW 2205 Sydney Australia  
Postal Address PO Box 90  
Amcliffe NSW 2205 Sydney Australia

**T:** +61 2 9567 0401  
**F:** +61 2 9597 7773  
**W:** [www.macnaught.com.au](http://www.macnaught.com.au)

MDT\_im\_issue4 © 2024



**Note:**  
This product should be disposed of according to all applicable local and national government environment regulations and guidelines.

