

INCLUDES MODELS  
IM012P-01  
IM012P-02

# POSITIVE DISPLACEMENT FLOWMETER - IM012P (PULSE)

## INSTRUCTION MANUAL



### To the Owner

**PLEASE READ THIS INFORMATION CAREFULLY  
BEFORE USE.**

Read and retain this instruction manual to assist you in the operation and maintenance of this product.

If you have any problems with the meter, refer to the maintenance and trouble shooting sections of this manual.

This manual contains connection and operating instructions for meters with Pulse outputs.

If you need further assistance, please contact your local representative or distributor for advice.

This Flow Meter has incorporated the oval rotor principal into its design. This has proven to be a reliable and highly accurate method of measuring flow.

Exceptional repeatability and high accuracy over a wide range of fluid viscosities and flow rates are features of the oval rotor design. With a low pressure drop and high pressure rating oval rotor flow meters are suitable for both gravity and pump (in line) applications.



### Important Information



### WARNING

**Before use, confirm the fluid to be used is compatible with the meter. Refer to Industry fluid compatibility charts or consult your local representative for advice.**

### Operating Principle

When fluid passes through the meter the rotors turn, as shown below. The magnets which are located in the rotors will pass across the PCB sensors.

A signal is generated which is then sent by the PCB to the relevant LCD, or receiving instrument as a Pulse Output.

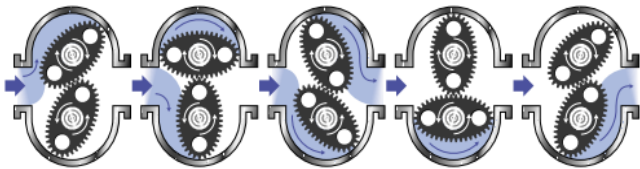

### INSTALLATION

1. Ensure fluid used is compatible with the meter.
2. It is strongly recommended that a strainer is installed before the meter for every application. Meters damaged by particles in the fluid may not be covered by warranty.
3. To prevent meter damage from entrapped air, during initial commissioning or after maintenance, slowly refill slowly pipe system with fluid before starting the pumping system.
4. Use a liquid thread sealant on all pipe fittings.
5. Use flexible pipe connections to prevent meter strain.
6. **Ensure the meter is mounted with the shafts in the horizontal plane.**
7. Fit a system pressure relief valve to prevent meter damage due to thermal expansion.
8. Refer to specifications for sensor electrical details.

### Maintenance Procedures.

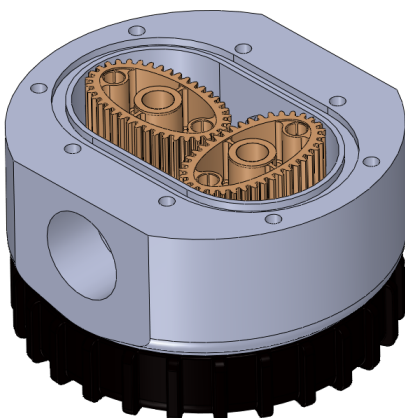

### Disassembly

Ensure that the fluid supply to the meter is disconnected, and the line pressure is released before disassembly, with the exception for repair or maintenance to the PCB where it is not necessary to isolate the meter from flow. Refer to the exploded parts diagram on subsequent pages for item numbers.

1. Unscrew the four retaining screws (item 2) and remove the Electronic Module (item 3)
2. Check for evidence of moisture into the electronic housing. If there is evidence of this check the condition of the O-Ring (item 4)
3. To access the Rotor assembly, remove the 8 Meter Cap screws (item 9)
4. Remove the rotors (item 6) and inspect the condition of each.  
Also investigate if there is the presence of any foreign material in the meter body, that may inhibit the rotors performance

### Reassembly

Note:

1. **The rotors must be fitted with rotor magnets facing up towards the electronic module** (i.e. The magnets being in close proximity to the Electronic module).

When replacing the rotors the top face of the rotors should be flush with the sealing face of the meter body.

2. Replace the rotors (Item 6) onto the shafts at 90 degrees to each other (as per diagram on the left) and check their operation by turning either of the rotors.  
If the rotors are not 'in mesh' correctly or do not move freely, remove one of the rotors and replace correctly at 90 degrees to the other rotor.
3. Check the Rotors (item 6) rotate freely.
4. Replace the O-Ring (item 7) into the groove of the Meter Cap (item 8).
5. Replace the Meter Cap onto Meter Body (item 5) Tighten Meter Cap screws (item 9) in a diagonal sequence to 7 Nm  
E.g. 1, 5, 3, 7, 4, 8, 6, 2
6. Replace the O-Ring (item 4) into the Electronic Module (item 3) and mount the Electronic module onto to the Meter Body
7. Replace and tighten the Retaining Screws (item 2) in diagonal sequence.
8. Before returning to service test the meter by turning the Rotors with your finger. Or applying a very low air pressure (no more than a good breath) to the meter

## Reed Switch

Please Note: Not dependant on Polarity

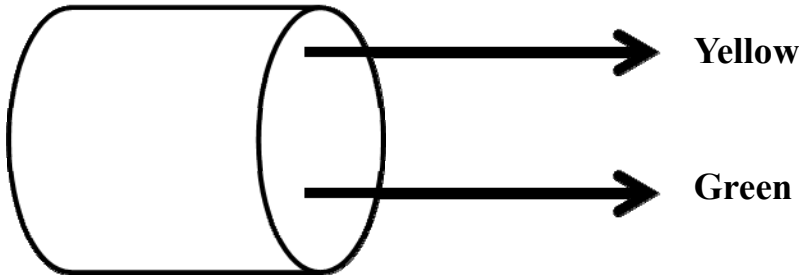

### Product Specifications

Accuracy	+/-0.5% of reading
Type	Oval Gear
Flowrate	1-30L/m (0.26 - 8 US Gal/m)
Maximum Pressure	6900 kPa / 1000psi / 69 Bar
Maximum Viscosity	1000 cP (Centipoise)
Maximum Temperature	55 Deg C / 131 Deg F
Minimum Temperature	-14 Deg C / 6.8 Deg F
K'Factor	112 pulses / Litre - 423.9661 pulses / USG

### Reed Switch specifications

	Conditions	Max	Units
Contact Rating	Any DC combination of V & A not to exceed their individual max's	10	W
Operating Voltage		30	VDC
Operating Ampere		0.5	A
Switching Current		0.5	A
Sensor-resistance		280	mΩ

\* When tested with lubrication oil 100 @ 25°C. Allowances should be made for changes to these parameters.

### Troubleshooting Guide

Problem	Cause	Remedy
Fluid will not flow through meter	a) Foreign matter blocking rotors b) Damaged rotors c) Meter connections over tightened d) Fluid is too viscous	a) Dismantle meter, clean rotors b) Replacement rotor assembly required. c) Re-adjust connections d) See specifications for maximum viscosity
Reduced flow through meter	a) Partially blocked b) Fluid is too viscous	a) Check and clean meter. b) See specifications for maximum viscosity
Meter reading inaccurate	a) Fluid flow rate is too high or too low b) Air in fluid. c) Excess wear.	a) See specifications for minimum and maximum flow rates b) Bleed air from system c) Check meter body and rotors. (see instructions)
Meter not giving a pulse signal	a) Faulty reed switch b) Magnets failed	a) Replace PCB Board b) Replacement rotor assembly required

**Exploded Diagram**

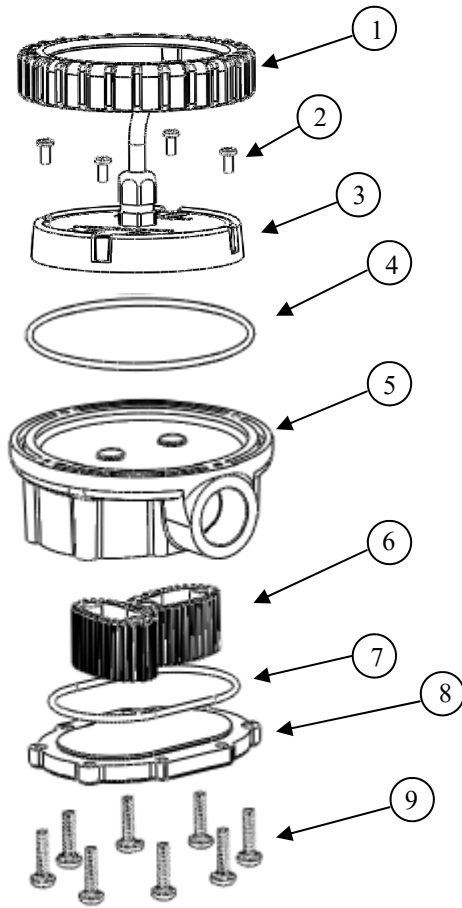

**Parts Identification**

Item no	Description	Wetted Parts
1	Protective boot	
2	Retaining screws	
3	Electronic module	
4	O'ring	
5	Meter Body	CA313 Aluminium
6	Rotor Set	Acetal (Delrin)
7	O'ring	Nitrile Butadiene Rubber (NBR)
8	Meter Cap	CA313 Aluminium
9	Meter Cap Screws	



**Spare Part Codes**

	Component	Description
<i>To order a replacement Electronic Module please contact your Macnaught representative</i>	Electronic Modules	Module Reed Switch

**Meter Dimensions (mm)**

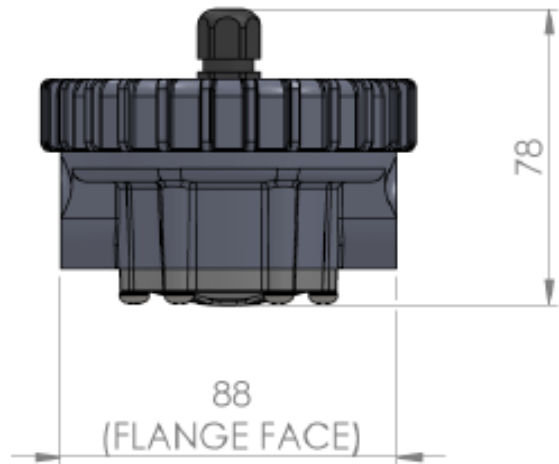



**LUBE**  
Control

Lube Control Pty Ltd

**Notes**



**LUBE**  
Control

Lube Control Pty Ltd

**Notes**



**Lube Control Pty Ltd**

**LUBE  
Control**



**Macnaught Pty Limited**  
ABN 66 000 075 785

41-49 Henderson Street  
Turrella NSW 2205 Sydney Australia  
Postal Address PO Box 90  
Amcliffe NSW 2205 Sydney Australia

**T:** +61 2 9567 0401  
**F:** +61 2 9597 7773  
**W:** [www.macnaught.com.au](http://www.macnaught.com.au)

**Note:**

This product should be disposed of according to all applicable local and national government environment regulations and guidelines.



**For Warranty Terms and Conditions see [macnaught.com.au](http://macnaught.com.au)  
For a list of Australian Service Centres see [macnaught.com.au](http://macnaught.com.au)**