

INTRODUCTION TO PRESSURE DIFFERENTIAL PRODUCTS

Frequent operation start-ups and environmental temperature swings in mechanical equipment can cause the air pressure inside oil sumps to increase and decrease, causing it to “breathe.” This “breathing” air, in most cases, comes from the external atmosphere through vents, fill ports, seals, and anywhere the oil sump is open to atmosphere. This can cause debris, dirt, and moisture to enter the equipment attacking and breaking down the equipments vital lubricant and ultimately reducing the life of bearings and gears.

The EQUALIZER® Expansion Chamber reduces or eliminates this “breathing” action by replacing the vent, providing an extra 25 cubic inches of airspace, by a rolling diaphragm. This provides the extra air volume necessary to overcome expansion and retracting inside the housing, *eliminating the need for equipment to “breathe” contaminated and damaging external air.* But, just how much of this “breathing” occurs? Below is a typical installation of a common piece of equipment and the effects of temperature fluctuations.

Using the following volume and temperature parameters, these values can be entered into the plug-in worksheet supplied at:

www.tricocorp.com/technical/sizing-expansion-cham.aspx, or follow the **Selection of an Expansion Chamber** worksheet supplied on the following page. As shown here, a relatively common occurrence can produce up to almost 18³ in of air expansion which escapes through the seals or vents. Conversely, that 18³ in needs to return to the housing when temperatures cool. That is when the damage is done.

Closing your system is the most effective way to eliminate harmful contaminates from entering your system and the Equalizer Expansion Chamber supplies the added air volume to eliminate the need for breathing due to temperature fluctuations. This is especially important when used in harsh or contaminated environments and when frequent start-up and shut-downs are necessary.

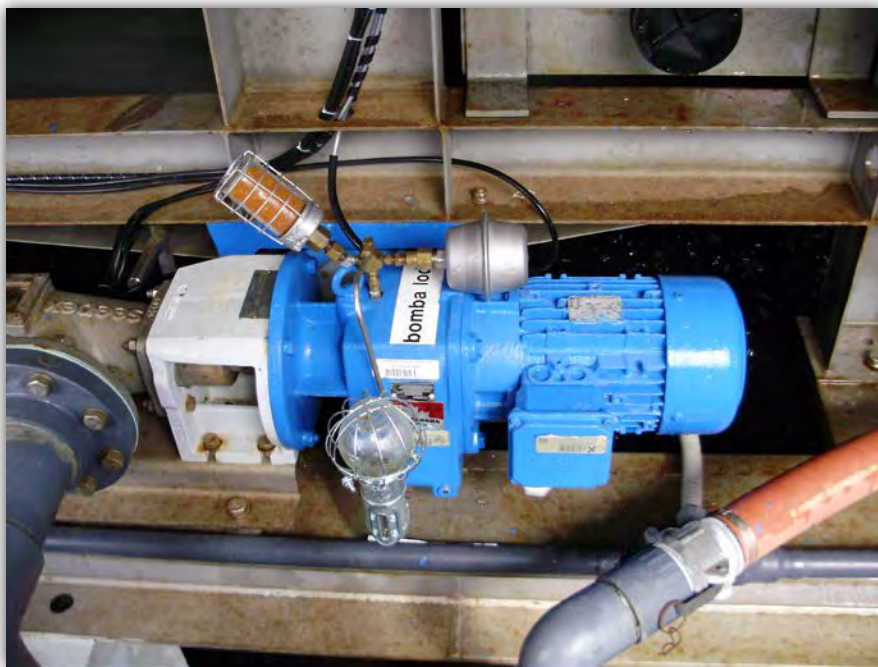

| Amount of Oil in Housing (oz) | Temp. Range of Housing (F) | | Total Volume in Housing (oz.) | Total Expansion |
|-------------------------------|----------------------------|-----|-------------------------------|--------------------|
| | High | Low | | |
| 32 | 110 | 60 | 128 | 17.81 cubic inches |

EQUALIZER EXPANSION CHAMBERS

Equalizer Expansion Chambers are designed to prevent pressure increase in closed systems. A rolling diaphragm provides a variable volume, that when properly sized, maintains oil housing pressure at or near zero PSI. The reduced pressure will extend seal life and help prevent leakage. Expansion chambers also protect the integrity of closed systems by preventing the exchange of air from the chamber to the surrounding atmosphere. A choice of thread sizes offers flexibility to the user.

FEATURES

- Made from corrosion resistant stainless steel
- Controlled housing pressure extends seal life
- Prevents contamination ingress to help lubricants stay cleaner for longer life and improved performance
- Full 25 cubic inch air expansion capability
- Maintenance free operation

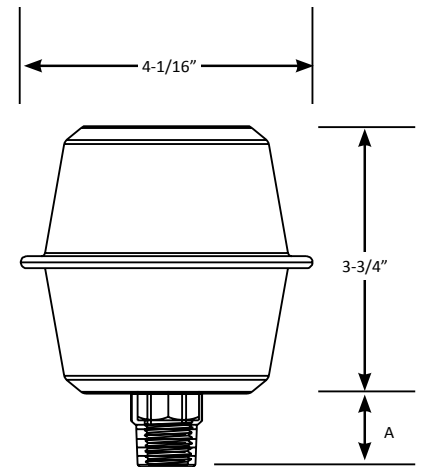
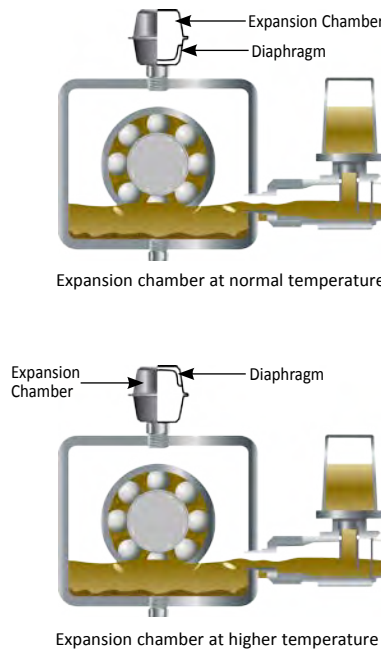

HELPFUL TIP:

Prevention of oil contamination and degradation is very often the most reliable means of preventing equipment failures. By minimizing the ways that contamination can enter equipment, lubricant cleanliness levels are increased. Products such as the Watchdog Oilers, Opto-Matic Closed System Oilers, Equalizer Expansion Chambers, and Watchdog Breathers, can help lubricants remain cleaner longer.

* For application assistance on calculating required capacities, please contact Trico or visit our web site for an online worksheet at www.tricocorp.com/technical/sizing-expansion-cham.aspx.

SELECTION CHART

| Model No. | Connection (NPT) | Capacity | Dim. (A) (in.) |
|-----------|------------------|------------|----------------|
| 31815 | 3/8 | 25 cu. in. | 7/8 |
| 31816 | 1/2 | 25 cu. in. | 1 |
| 31817 | 3/4 | 25 cu. in. | 1-1/4 |

SPECIFICATIONS

| | |
|----------------------|-----------------|
| Body | Stainless Steel |
| Diaphragm | Viton® |
| Max. Operating Temp. | 350°F |





SELECTION OF AN EXPANSION CHAMBER

DETERMINE TOTAL AIR EXPANSION

To determine the correct expansion chamber size required for your application, obtain the following data and follow the steps listed below. Please visit our website for assistance on calculating required capacities at www.tricocorp.com/technical/sizing-expansion-cham.aspx.

1. The amount of oil, in ounces, normally in the bearing housing. _____ oz.
2. Multiply above answer by 1.804 to obtain _____ in³ (oil volume). Place this value into the table below **STEPS A & B** in³ (oil volume).
3. The temperature range of the bearing housing. High _____ °F Low _____ °F. Place High & Low temperature in **STEP C**. Subtract the low from the high and place in **STEP A** (high-low temp).
4. Complete **STEP A**. Multiply oil volume by temperature difference and coefficient of expansion. (NOTE: .0004 is coefficient of expansion for most turbine oils). Place answer in **STEP D**, in³ (oil expansion).
5. The total volume of the bearing housing. Many customers may not know this. Contact your pump manufacturer for this information. _____ oz. (total volume).
6. Multiply answer from above by 1.804 to obtain _____ in³ (sump volume). Place this value into the table **STEP B** in³ (sump volume).
7. Complete **STEP B**, subtract in³ (oil volume) from in³ (sump volume) to get in³ (air volume) and place answer in both places in **STEP C**, in³ (air volume).
8. Follow instructions in **STEP C** to get in³ (air expansion). Place answer into **STEP D** in³ (air expansion).
9. Complete **STEP D** by adding to get in³ (total expansion), with this information you can select the correct size expansion chamber for your application.

BEFORE STARTING, OBTAIN THE FOLLOWING DATA:

1 Amount of Oil in Housing (oz.)

2 Temp. Range of Housing (°F)

| | |
|--|------|
| | High |
| | Low |

3 Total Volume in Housing (oz.)

| | |
|---------------|--|
| STEP A | Multiply the volume of oil with the temperature span to get oil expansion. _____ in ³ (oil volume) X _____ °F (high-low temp) X .0004 = _____ in ³ (oil expansion) |
| STEP B | Subtract the oil volume from the sump volume to get air volume. _____ in ³ (sump volume) — _____ in ³ (oil volume) = _____ in ³ (air volume) |
| STEP C | Determine the absolute temperature range for air, divide high temp + 460 by low temp +460. Multiply (air volume) with temperature factor. Then subtract the (air volume) to get the air expansion for the maximum change in temperature. _____ in ³ (air volume) X $\frac{(\text{_____ high temp} + 460)}{(\text{_____ low temp} + 460)}$ — _____ in ³ (air volume) = _____ in ³ (air expansion) |
| | Add (oil expansion) with (air expansion) to get total expansion |

CLOSED SYSTEM HOT SETUP KIT

Pressure differential between the equipment housing and surrounding atmosphere is a leading cause of moisture ingress. Equipment operation where housing temperature fluctuations occur during frequent on/off running conditions, process fluid temperature changes, outdoor use, and air flow over the equipment create a “breathing” condition as pressure is equalized.

This “breathing” condition allows moisture to be introduced into the equipment causing the oil to absorb it at a variable rate depending on temperature, oil type, and lubricant agitation. The Closed System Hot Setup kit is used to minimize the detrimental effects of equipment “breathing.”

FEATURES

- Includes all necessary fittings and hardware for quick, easy installation
- All fittings are in 316 Stainless Steel for corrosion resistance

SPECIFICATIONS

| Model No. | Description |
|-----------|--|
| 40103 | Closed System Hot Setup Kit with 4 oz Closed System Oiler |
| 40105 | Closed System Hot Setup Kit with 8 oz Closed System Oiler |
| 40110 | Closed System Hot Setup Kit with 16 oz Closed System Oiler |

