

## AC Gear-type Oil Pump

### User's Manual



 **WARNING:** Read carefully and understand all **INSTRUCTIONS** before operating. Failure to follow the safety rules and other basic safety precautions may result in serious personal injury.

**Model No. DITI17320400**

### Machine Description

**Pump:** Electric self-priming rotary internal gear pump, equipped with a by-pass valve

**Motor:** Asynchronous motor, 4-pole, closed type (Protection class IP55), self-ventilating, flange-mounted directly to the pump body.



## 1. Technical Information

### 1.1 Electrical Information

PUMP MODEL	ELECTRICAL POWER			POWER	Pressure	Flow Rate
	Current	Voltage (V)	Frequency (HZ)	Nominal (watt)	Maximum	
17320400	AC	230	50	1100	10 BAR	40LPM
17320401	AC	380	50	1100	10 BAR	40LPM
17320500	AC	120	60	1100	72 PSI	52Quarts/min.
17320501	AC	120	60	1500	145 PSI	52Quarts/min.

#### **ATTENTION!**

The power absorbed by the pump depends on the functioning point and the viscosity of the oil being pumped.

## 2. OPERATION CONDITIONS

### 2.1 Environmental Conditions

Temperature: Min -10°C / max+60°C

Relative Humidity : max 90%

#### **ATTENTION!**

The temperature limits indicated are applied to the pump components and must be respected to avoid possible damage or malfunction.

It is understood, nevertheless, that for a given oil, the real functioning temperature range also depends on the variability of the viscosity of the oil itself with the temperature. Specifically:

- The minimum temperature allowed (-10°C) could cause the viscosity of some oils to greatly exceed the maximum allowed, with the consequence that the static torque required during the starting of the pump would be excessive, risking overload and damage to the pump.
- The maximum temperature allowed (+60°C) could, on the other hand, cause the viscosity of some oils to drop well below the minimum allowed, causing a degradation in performance with obvious reductions in flow rate as the back pressure increases.

The maximum acceptable variations from the electrical parameter are:

**Voltage:** ±5% of the nominal value

**Frequency:** ±2% of the nominal value

#### **ATTENTION!**

Electrical power from lines with values outside the limits indicated can cause damage to the electrical components.

### 2.2 Working Cycle

Under normal operating conditions they can function continuously with no limitations.

#### **ATTENTION!**

**Functioning in by-pass conditions is only allowed for brief periods (2 minutes maximum).**

Whenever a particular installation carries the risk of functioning in by-pass mode for longer periods of time, it is necessary that the by-passed flow not be recirculated inside the pump, but be returned to the suction tank.



**2.3 Fluid Allowed / Fluids Not Allowed**

**ALLOWED:** Oil with a Viscosity from 500 to 2000 Cst (at working temperature)

NOT ALLOWED	RELATED DANGER
Gasoline (Petrol)	Fire - explosion
Inflammable liquids with PM < 55°C	Fire - explosion
Water	Oxidation of the pump
Liquid food products	Contamination of same
Corrosive Chemicals	Corrosion of the pump Injury to people
Solvents	Fire – explosion Damage to gasket seals

**ATTENTION!**

The gear pump is sensitive to those polluted fluid, DO NOT deliver the fluid contained too much impurity.

**3. MOVING AND TRANSPORTING**

Given the limited weight and size of the pumps, moving the pumps does not require the use of lifting equipment.

The pumps are carefully packed before shipment. On receipt, check the packing materials and store in a dry place.

**4. INSTALLATION**

**4.1 Preliminary Inspection**

- Check that the machine has not suffered any damage during its transport or warehousing.
- Clean the inlet and outlet openings with care, removing any dust or packing residue.
- Make sure that the motor shaft turns freely.
- Check that the electrical information corresponds with what is shown on the label.

**4.2 Mechanical Installation**

The gear pumps can be installed in the following ways:

- a. On an horizontal base:

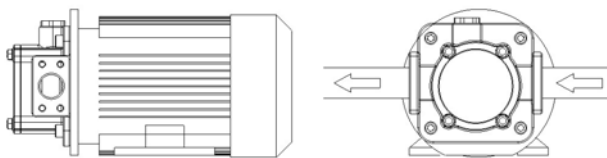



**LUBE  
Control**

Lube Control Pty Ltd

b. With the pump body upwards

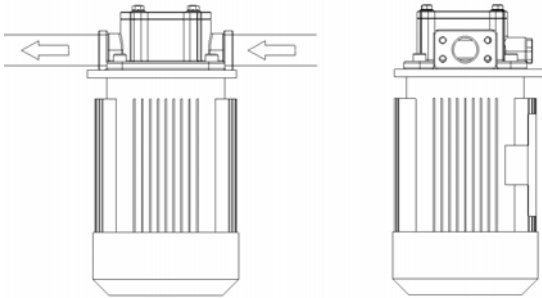

c. With pump body aside

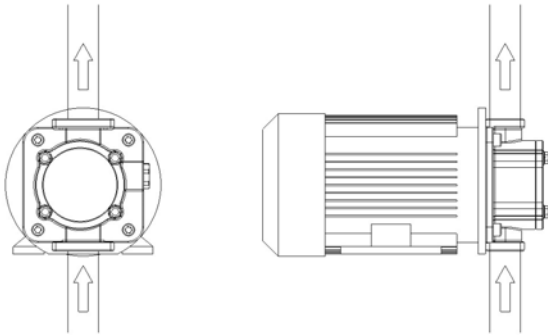

#### **WARNING**

DO NOT install the pump vertically with the pump body downwards.

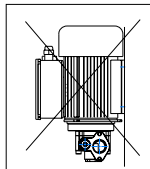

Do not install the pump at the inflammable & steamy place.

If absolutely necessary, install a foot-valve and fill the suction tube with oil during the first priming phase.

Fix the pump using screws of a diameter suitable for the provided fixing holes as indicated in the drawing.

#### **4.3 HYDRAULIC CONNECTION**

- Make sure that the hoses and the suction tank are free of dirt and filling residue that might damage the pump and accessories.
- Always install a metal mesh filter in the suction hose.
- Before connecting the delivery hose, partially fill the pump body with oil to avoid the pump running dry during the priming phase.



The **MINIMUM recommended** characteristics for hoses are as follows:

**SUCTION HOSE**

- Diameter: 1"
- Nominal pressure: 2 times the pressure P bypass
- Appropriate for use with suction

**DELIVERY HOSE**

- Diameter: 1"
- Nominal pressure: 2 times the pressure P bypass

**ATTENTION!**

The use of hoses and/or line components that are inappropriate for use with oil or have inadequate nominal pressures can cause damage to objects or people as well as pollution.

The loosening of connections (thread connections, flanges, gasket seals) can likewise cause damage to objects or people as well as pollution.

**4.4 SUCTION & DELIVERY LINES**

**DELIVERY**

The choice of pump model to use should be made keeping in mind the viscosity of the oil to be pumped and the characteristics of the system attached to the delivery of the pump. The combination of the oil viscosity and the characteristics of the system could, in fact, create back pressure greater than the anticipated maximums (equal to P max), so as to cause the (partial) opening of the pump by-pass with a consequent noticeable reduction of the flow rate supplied.

In such a case, in order to permit the correct functioning of the pump equal to the viscosity of the oil being pumped, it will be necessary to reduce resistance in the system by employing shorter hoses and/or of larger diameter.

On the other hand, if the system cannot be modified it will be necessary to select a pump model with a higher Pressure.

**SUCTION**

The gear-type oil pumps are characterized by excellent suction capacity. In fact, the characteristic flow rate/back pressure curve remains unchanged even at high pump suction pressure values.

At the initial start-up, the maximum priming height can reach 2M when the suction hose is empty and the pump is filled by the fluid. So during this period, the height between the pump & fluid should be less than 2M. If exceed this height, it would be better to assemble a foot valve or use a larger diameter suction hose. It is suggested never install a pump over 3M height.

**5. INITIAL START-UP**

The gear-type oil pumps are self-priming and therefore, able to draw oil from the tank even when the suction hose is empty on start-up. The priming height (distance between the surface of the oil and the inlet opening) must not exceed 2M.

**WARNING**

Wetting the pump. Before starting the pump, wet the inside of the pump body with oil through the



inlet and outlet openings.

If the pump is already installed, the wetting operation can be performed by unscrewing the threaded plug of the inlet opening not in use, by filling the internal chamber with oil and screwing in the plug, paying attention to the O-ring seal.

If no foot valve is installed, it is advisable to leave the purge valve always open so that once the device is re-started again, it is ready to purge the air present in the suction tube. Please consider that during the operation, a small part of oil re-circulates in the tank.

If a foot valve is installed, close the air purge valve by turning it clockwise, so that no oil circulates in the tank. If the foot-valve seal is not perfectly tight, the suction tube may be emptied and the purging operation described above must be repeated.

The priming phase may last from several seconds to a few minutes, depending on the characteristics of the system.

If this phase is excessively prolonged, stop the pump and verify:

- That the pump is not running completely “dry”
- That the suction hose guarantees against air infiltration and is correctly immersed in the fluid to be drawn
- That any filters installed are not blocked
- That the priming height is not greater than 2M
- That the delivery hose allows for the easy evacuation of the air

When priming has occurred, after reattaching the delivery gun, verify that the pump is functioning within the anticipated ranges, possibly checking:

- 1) that under conditions of maximum flow the energy drawn by the motor falls within the values indicated on the label
- 2) that the back pressure in the delivery line does not exceed the values indicated in paragraph 6.4

## SUCTION & DELIVERY LINES

## 6. EVERY DAY USE

### 6.1 Manual Operation

- 1) Before starting the pump, make sure that the ultimate shut-off device (delivery gun or line valve) is closed.
- 2) Turn the on-switch
- 3) Make sure that the tank is filled with a quantity of oil greater than the quantity to be supplied (running dry could damage the pump)

#### **ATTENTION**

Never start the pump by simply inserting the plug in the outlet.

- 4) Open the delivery valve or activate the delivery gun, gripping it securely.
- 5) Close the delivery gun or the line valve to stop delivery. The pump will immediately enter by-pass mode

#### **ATTENTION**

Running in by-pass mode with the delivery closed is only allowed for brief periods (2 to 3 minutes maximum).

- 6) Stop the pump



## 7. PROBLEMS AND SOLUTIONS

PROBLEM	POSSIBLE CAUSE	CORRECTIVE ACTION
Motor does not turn	Lack of power	Check electrical connections and safety systems
	Rotor blocked	Check for possible damage or obstruction to rotating parts
	Thermal motor protector has triggered	Wait until the motor cools, verify that it starts again, look for the cause of overheating
	Problems with the motor	Contact technical support
Motor turns slowly when starting	Low voltage from the electrical power supply	Adjust the voltage within anticipated limits
	Excessive oil viscosity	Verify oil temperature and warm it to reduce excessive viscosity
LITTLE OR NO FLOW	Low level in the suction tank	Fill in the tank
	Foot valve blocked	Clean and/or replace valve
	Filter blocked	Clean the filter
	Excessive suction pressure	Lower the pump with respect to the level of the tank or increase the cross-section of the hose
	High load loss in the delivery circuit (running with by-pass open)	Use shorter hose or of wider diameter
	By-pass valve blocked	Detach the valve, clean or replace it
	Air in the pump or suction hose	Check the seal of the connection
	Narrowing of the suction hose	Use a hose appropriate for working under suction pressure
	Low rotation speed	Check the voltage at the pump. Adjust the voltage or use cables of greater cross-section
	Excessive oil viscosity	Verify the oil temperature and warm it to reduce the excessive viscosity
HIGHER PUMP NOISE	Cavitation	Reduce the suction pressure
	Irregular by-pass functioning	Deliver until the air in the by-pass system is purged
	Presence of the air in the oil	Wait for the oil in the tank to settle
LEAKAGE FROM THE PUMP BODY	Damage to the mechanical seal	Check and replace the mechanical seal



## 8. MAINTENANCE

- On a weekly basis check that the hose joints have not loosened, to avoid any leakage
- On a monthly basis check the pump body and clean it removing any impurities.
- On a monthly basis check and clean the filters placed at the pump inlet.
- On a monthly basis check that the electric power cables are in good condition.

## 9. NOISE LEVEL

Under Normal operating conditions noise emission for all models does not exceed the value of 70 db “A” at a distance of 1 Meter from the electric pump.

## 10. EXPLODED DIAGRAMS AND SPARE PARTS

Part. No.	Description	Qty.
1	Motor	1
2	Key	1
3	Machined pump head	1
4	Hex Screw M10X20	4
5	By-pass valve	1
6	Spring	1
7	O-Ring 22.4X2.65	1
8	By-pass plug	1
9	Machine Seal	1
10	O-ring	1
11	internal rotor	1
12	external rotor	1
13	O-ring 90X2.65	1
14	Pump Cover	1
15	Hex Bolt M8x15	4

